

GEARING INDUSTRIES

ECON 2

SERIES

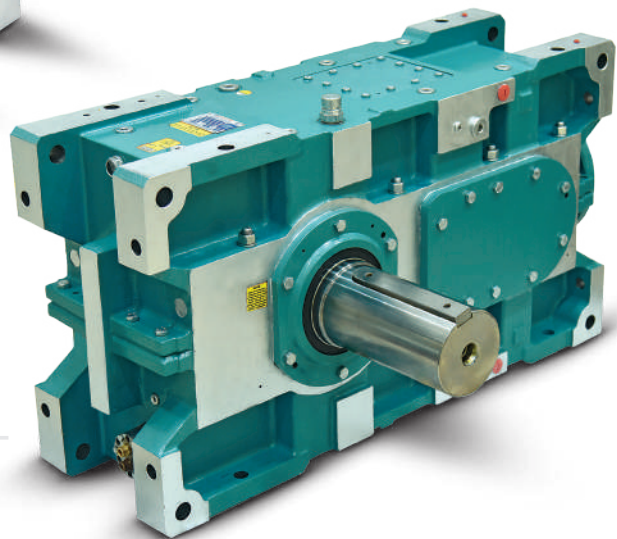
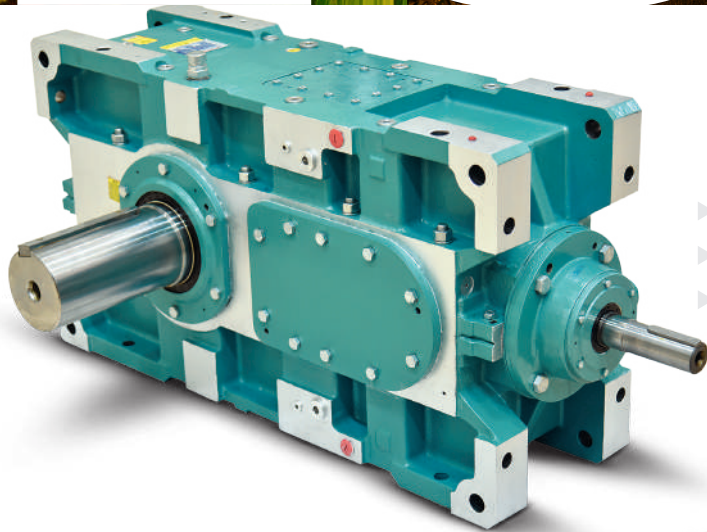

HELICAL AND
BEVEL HELICAL
GEAR UNITS

www.elecon.com



INFRASTRUCTURE



WORLD'S MOST TECHNOLOGICALLY ADVANCED GEAR MANUFACTURING FACILITY

BHANUBHAI MEMORIAL CENTRE OF EXCELLENCE (BMCE)

In the last seven decades, Elecon have conducted intensive research in gear technology and manufacturing techniques. We have developed a variety of products in the transmission industry from worm gears to helical, from planetary to variable speed fluid couplings. This development has demanded a significant investment in manufacturing capability from gear cutting right through to heat treatment and profile grinding. This new plant has the capacity to manufacture sufficient helical gears to produce 1000 assembled gear units per month.

This plant is a tribute to our founding Chairman, Lt. Shri Bhanubhai Patel, who wanted to remain "Always a step ahead in technology"



HELICAL AND BEVEL HELICAL GEAR UNITS



HELICAL AND BEVEL HELICAL GEAR UNITS

01. Products Overview	02
02. Introduction	09
03. Design of the gear units	15
04. Helical gear unit	55
05. Bevel helical gear unit	89
06. Compact drive gear unit	125
07. Output shaft dimensions	155
08. Options for add on components	167

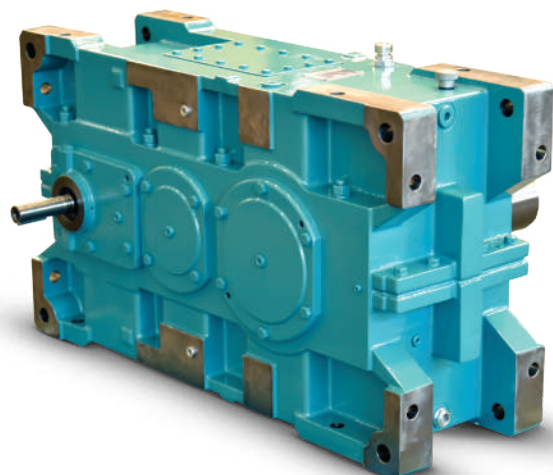
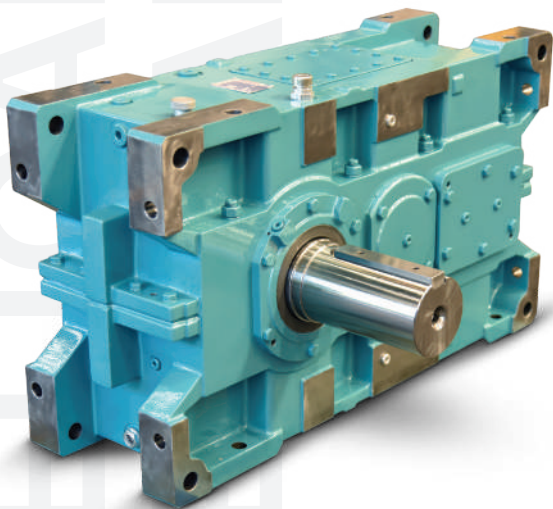



PRODUCTS OVERVIEW

- 1.1 Elecon products catalogue overview
- 1.2 Elecon other products

RELIABLE SOLUTION FOR ALL INDUSTRY



Gearing industries. Gearing economies.

ELECON PRODUCTS CATALOGUE OVERVIEW

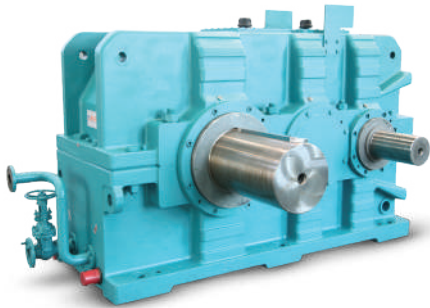

Helical Gear Unit

Ratio: 2:1.....400:1

Torque: 140 kNm...1400 kNm

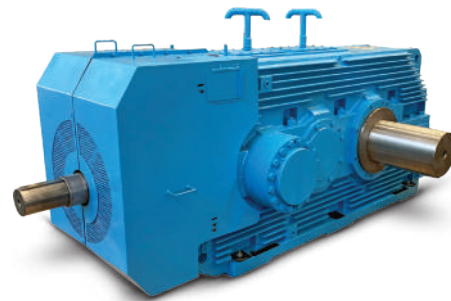

Bevel Helical Gear Unit for Conveyor Drive

Ratio: 5:1.....80:1

Toque: 140 kNm - 1400 kNm



Cooling Tower Application

Ratio: 8:1.....16:1

Torque: up to 80 kNm

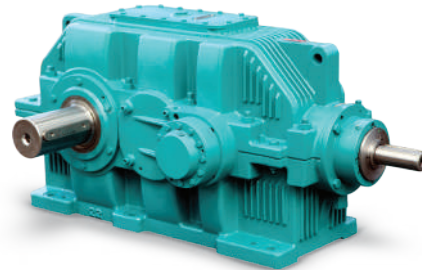

General Application

Ratio: 1.25:1 to 560:1

Torque: up to 120 kNm



Vertical Rolling Mill

Ratio: 16:1.....50:1

Torque: up to 2500 kNm



High Speed Gear Unit

Prime Mover Power: up to 50 MW

Input Speed: up to 14000 rpm

ELECON PRODUCTS CATALOGUE OVERVIEW



Sugar Mill Drive

Gear Box Ratio: 63:1 to 500:1
Output Torque: up to 8000 kNm



UNDER DRIVEN (SNU-U), OVER DRIVEN (SNU-O)

Ratio: 5:1.....70:1
Power: up to.....350 kW

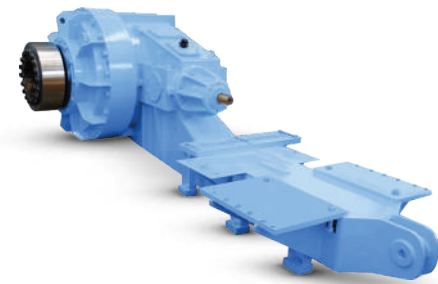

Bucket Wheel Drive Gear Box

Ratio: 140:1 to 400:1
Toque: up to 800 kNm

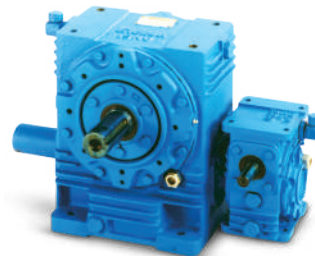

Double Reduction Worm

- Under Driven (SNU - UD)
- Over Driven (SNU - OD)
- Vertical Output Shaft up/down (SNU-VD)
- Hollow Output Shaft (SNU-SMD)

Ratio: 75:1.....4900:1
Power: 0.12.....50 kW

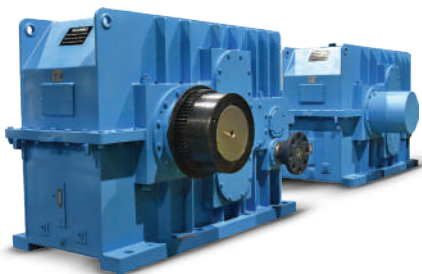

Dual Tandam (kiln drive and Sugar mill drive)

Ratio: 45:1 to 250:1
Torque: up to 2070 kNm



SNU – CVDM / CVDM

Heavy Duty stirrer unit incorporates as extended bearing housing to accommodate a larger bottom bearing and increased shaft size, absorb high bending load during stirrer application. Facility for mounting motor on top.

Ratio: 5:1.....70:1
Power: 5.....350 kW

ELECON OTHER PRODUCTS

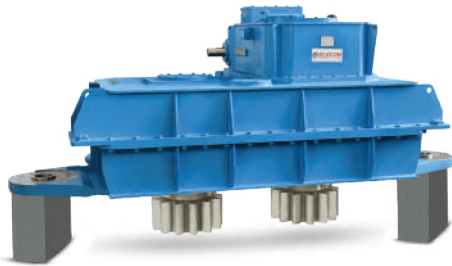

Main Slew Gear Box (Stacker Reclaimer Drive)

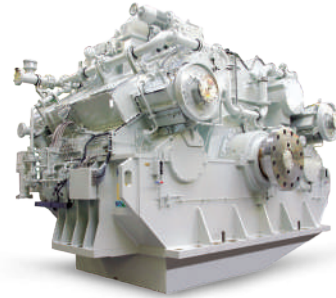

Marine Application



Rubber Mixer - Helical Gear Box



Rolling Mill Drive Helical Gear Box - Cum - Pinion Stand (Vertical)



Roller Press Application - Planetary Gear Box

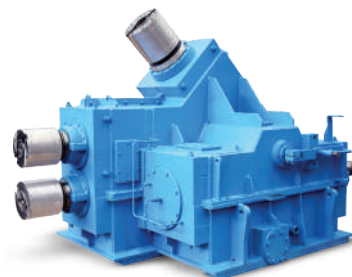

Rolling Mill Drive Gear Box - Cum - Pinion Stand - Combined - Horizontal & Vertical

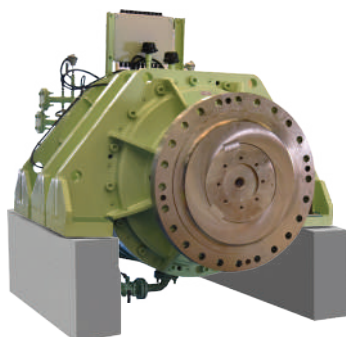

Cement Mill - Central Drive, Planetary Gear Box

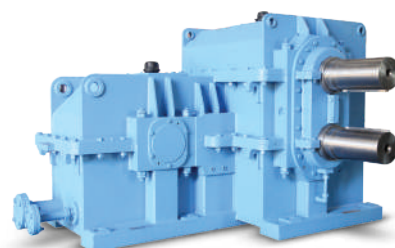

Rolling Mill Drive Helical Gear Box - Cum - Pinion Stand (Horizontal)

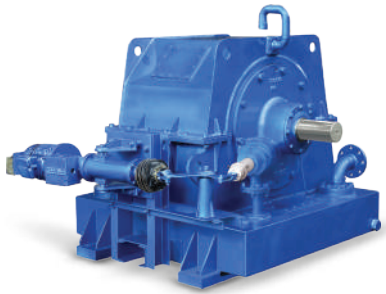

Scoop Coupling



Fluid Coupling



Geared Coupling



Flexible Coupling



Spiral Bevel Pair

Wheel Dia.: Up to 1100 mm
Module: Up to 14 mm



Large Worm Pair

(A) Small & Medium Size: up to 17"
(B) Special Size: 27" to 54" Worm
Pair for Coal pulverized mill of Coal fired
Thermal Power Station



Helical /Spur Gear Wheel



Pinion Shaft

ELECON OTHER PRODUCTS



Hot Sizing Mill Gearbox with Two Input & Seven Output Shafts - Seamless Tube Plant



Laddel Crane Main Hoist Drive



Steel Industry - Blooming



Wind Mill Gear Box

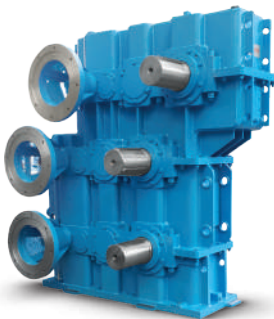

Mill Calendar Drive Gear Box

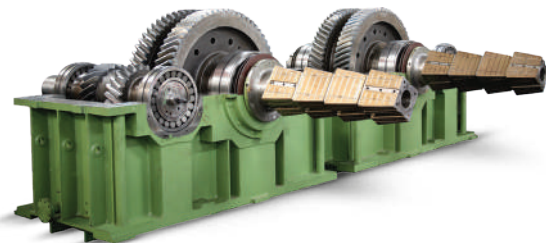

Heavy Duty ETR & DTR Gearbox with Double Helical Gearing

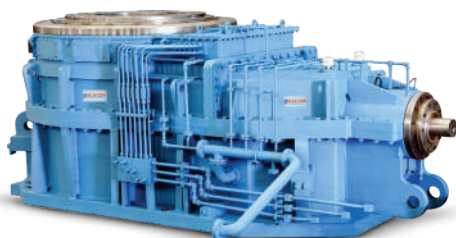

Raw Mill - Bevel Helical Gear Box



Helical Gear Box for Main & Aux. Hoist Drive - Winch

2. INTRODUCTION



INTRODUCTION

- 2.1 Nomenclature
- 2.2 Gear unit mounting
- 2.3 Information and highlight of series
- 2.4 Name plate structure

2.1 Nomenclature

GEAR UNIT PRODUCT CODE <u>H 4 716 H N - 3 A A NN 0 A - 0800 - 11</u>	
H	GEAR UNIT TYPE
	<ul style="list-style-type: none"> H Helical (Universal Mounting) B Bevel Helical (Universal Mounting) C Compact Drive (Universal Mounting)
4	NUMBER OF STAGES
	<ul style="list-style-type: none"> 1 Single Stage 2 Two Stage 3 Three Stage 4 Four Stage
716	GEAR UNIT SIZE
H	GEAR UNIT MOUNTING
	<ul style="list-style-type: none"> H Horizontal V Vertical O Over Driven U Under Driven T Torque Arm Provision M Mounting Flange (Output Shaft Side)
N	TYPE OF OUTPUT SHAFT
	<ul style="list-style-type: none"> N Solid Shaft With Key S Hollow Shaft With Spline C Cylindrical Shaft (Without Keyway) F Flanged Shaft K Hollow Shaft With Keyway V Solid Shaft With Spline D Hollow Shaft With Shrink Disc
3	TYPE OF GEARCASE
	<ul style="list-style-type: none"> 1 Cast Iron 2 SG Iron 3 Fabricated Steel Case 4 Special
A	ATTACHMENTS
	<ul style="list-style-type: none"> A None B Backstop C Torque Arm D Backstop + Torque Arm
A	MOTOR ADAPTOR
	<ul style="list-style-type: none"> A None B Main Motor Adaptor C Auxiliary Motor Adaptor* D Main + Auxiliary Motor Adaptor* <p style="text-align: right;">* On Request</p>
NN	MOTOR ADAPTOR FRAME SIZE (IEC / NEMA)
	<p> NN NONE SP SPECIAL MOTORS * (ON REQUEST) IEC MOTORS A1 100 D1 132M G1 180M K1 225S N1 280S R1 315M B1 112M E1 160M H1 180L L1 225M P1 280M C1 132S F1 160L J1 200L M1 250M Q1 315S NEMA MOTORS (*On Request) A2 182 D2 2215 G2 284 K2 326 N2 404 R2 445 B2 184 E2 254 H2 286 L2 364 P2 405 T2 447 C2 213 F2 256 J2 324 M2 365 Q2 444 </p>
0	TYPE OF COOLING
	<ul style="list-style-type: none"> 0 None 1 Single Fan 2 Cooling Coil 3 Oil Heater 4 Single Fan + Cooling Coil 5 Single Fan + Oil Heater 6 Additional Cooling System
A	TYPE OF LUBRICATION
	<ul style="list-style-type: none"> A. Splash B. Splash With Compensating Tank C. Motor Driven Pump
0800	NOMINAL RATIO x 10
11	SHAFT ARRANGEMENT

2.2 Gear unit mounting

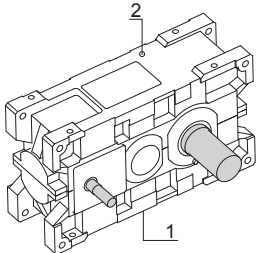
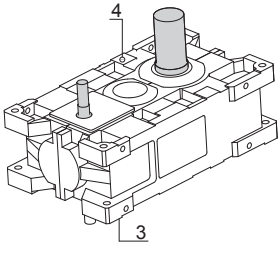
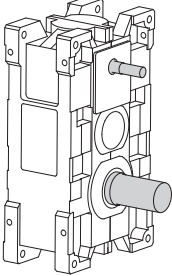
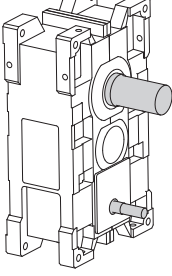
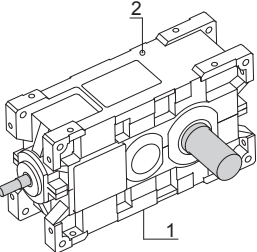
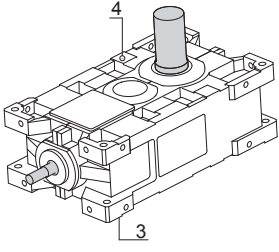
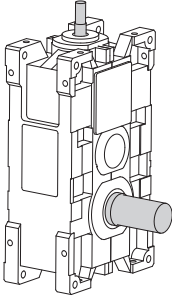
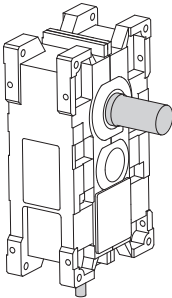
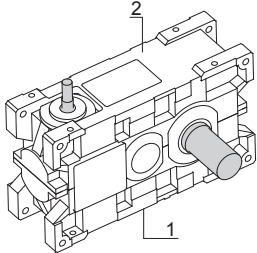
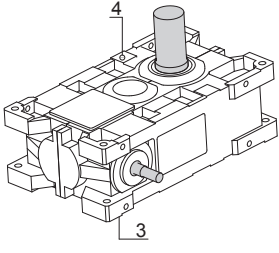
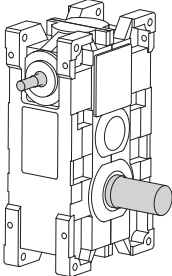
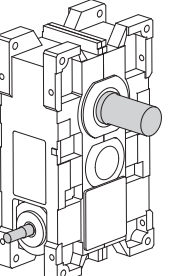
GEAR UNIT TYPE	HORIZONTAL	VERTICAL	OVER DRIVEN	UNDER DRIVEN
HELICAL GEAR UNIT	 <p>SURFACE - 1 180° SURFACE - 2</p>	 <p>SURFACE - 3 180° SURFACE - 4</p>		
BEVEL-HELICAL GEAR UNIT	 <p>SURFACE - 1 180° SURFACE - 2</p>	 <p>SURFACE - 3 180° SURFACE - 4</p>		
COMPACT DRIVE (BEVEL-HELICAL) GEAR UNIT	 <p>SURFACE - 1 180° SURFACE - 2</p>	 <p>SURFACE - 3 180° SURFACE - 4</p>		

* 180° Flip is not feasible for H1 & H4

MOUNTING SURFACES

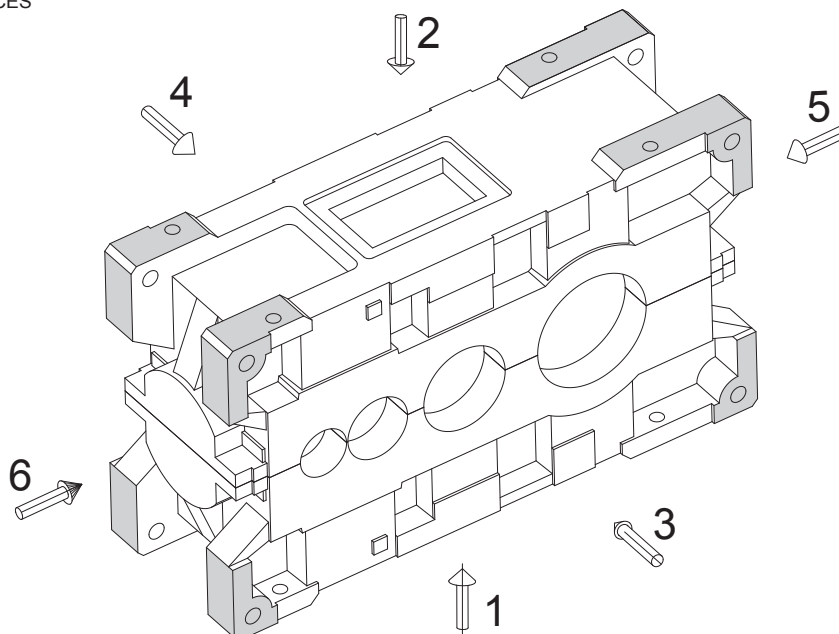

2.3 Information and highlight of series

Elecon believes in the continual improvement of existing products looking to customer needs and satisfaction.

Introducing our industrial gearbox - the perfect solution for your power transmission needs. What sets our gearbox apart is that it is a patented design (**Patent No. 375476-001, 375477-001**), which means you won't find it anywhere else. Our engineers have poured years of research and development into designing a gearbox that offers optimal performance, durability, and efficiency. With our patented gearbox, you can rest assured that you are using a state-of-the-art product that is truly unique in the market.

EON² series includes

- Split gear unit housing
- Variety of output shaft options
- Holdback / Backstop
- Splash lubrication, Built on pump, Motor driven pump
- Natural cooling, Fan cooling, Cooling coil, External oil cooling system
- RTD provision (On request)

EON² series introduces additional advantages

- Optimize gear units size suitable to torque rating
- Universal gear unit mounting positions.
- Reduces components varieties to make faster delivery to customer.
- Standard heating instruments
- Vibration sensor mounting provision (On request)
- Standard torque arm arrangement
- Standard complete drive selection
- Standard motor mounting adaptor
- Variety of sealing arrangements
- Variety of oil level check accessories

Thermal Capacities

EON² series gear units are designed for high efficiency and, in turn, optimized thermal rating without additional cooling accessories. The fan cowl is designed in such a way that forced air can take heat through gear unit surface more effectively. Variety of cooling coil options are available based on the customer's requirement. The external cooling system can be used to get maximum thermal rating.

Housing Material

Standard Gear housing material will be FG 260 as per IS 210. Special materials can be provided based on application and customer's requirements.

Gears

Helical gears with case harden and ground, optimised gear tooth profile modification for lower flash temperature. Spiral bevel gears (Cyclo-paloid) have been hardened and lapped or grind. The precise micro geometry of our industrial gearbox's gears provides optimal contact ratio, resulting in smoother and more efficient gear operation. Calculation checks in compliance with DIN 3990 and other standards on request.

Noise Level

Harden and ground tooth improves the noise emission of the gear unit. Also optimised tooth profile is responsible for lower noise.

Vibration Levels

Allowable vibration limits is generally as per ISO 10816.





2.3 Information and highlight of series

General Information

The following items are absolutely to be observed!

1. The weight of gearbox are mean values and not strictly binding.
2. Prior to commissioning, the operating instructions must be observed. The gear units are delivered ready for operation but without oil filling.
3. Oil quantities given are guide value only. The exact quantity of oil depends on the marks on the oil level dipstick.
4. The oil viscosity has to correspond to the data given on the name plate.
5. Approved lubricants should be used only. (Refer operating instruction manual)
6. The Gear case housings are protected against corrosion.
7. Foundation bolts are minimum property class-8.8.
8. Modification of dimensions reserved.
9. Shaft ends with keys according to DIN 6885, part 1, Shape A.
10. Shaft centering according to DIN 332, shape DS (with thread)
11. Tolerance field for shaft ends ISO fit, details refer separate page.
12. Shaft extension keys are supplied with gear unit. (excluding hollow shaft key)
13. All dimension are in millimeters unless indicated.

Symbols used in Dimension Drawings :

1. Oil dipstick 
2. Breather 
3. Drain plug 
4. Oil filling 

2.4 Name plate structure

GEARING THE FUTURE

TÜVRheinland Group®

Type	<input style="width: 95%;" type="text"/>	
Sr. No.	<input style="width: 95%;" type="text"/>	
WO. No.	<input style="width: 95%;" type="text"/>	
Oil/Qty.	<input style="width: 95%;" type="text"/>	
PE, kW	<input style="width: 15%;" type="text"/> n1, rpm <input style="width: 15%;" type="text"/> Wt. kg. <input style="width: 15%;" type="text"/>	
PN, kW	<input style="width: 15%;" type="text"/> Exact Ratio <input style="width: 15%;" type="text"/> Year of Mfg. <input style="width: 15%;" type="text"/>	

LUBRICATION : Before starting, fill Oil up to dipstick/oil indicator marking.
Refer O & M Manual for oil change interval & approved lubricant

Type	Gearbox type and designation
Sr. No.	Serial number
WO. No.	Work order number
Oil / Qty.	Oil grade / Oil quantity in litres. (Approx)
PE, kW	Absorbed power of machine OR motor power in kilowatt
PN, kW	Gearbox nominal power in kilowatt
n 1, rpm	Gearbox input speed in revolution per minute
Exact Ratio	Gearbox exact ratio
Wt. kg.	Approx. weight of gear unit in kilogram
Year of Mfg.	Year of manufacture
<input type="checkbox"/>	Location for QR code (For Information & enquiry)



DESIGN OF GEAR UNIT

- 3.1 Gear unit selection with example
- 3.2 Equivalent power with load spectrum
- 3.3 Service factors
- 3.4 Data tables – Type H1
- 3.5 Data tables – Type H2
- 3.6 Data tables – Type H3
- 3.7 Data tables – Type H4
- 3.8 Data tables – Type B2
- 3.9 Data tables – Type B3
- 3.10 Data tables – Type B4
- 3.11 Actual ratios – Type H1, H2, H3, H4
- 3.12 Actual ratios – Type B2, B3, B4
- 3.13 Mass moment of inertia – Type H1, H2, H3, H4
- 3.14 Mass moment of inertia – Type B2, B3, B4

3.1 Gear unit selection with example

1. Determination of gear unit type and number of stage

1.1 Select type of gear unit and mounting position.

1.2 Required transmission ratio

$$i_N = \frac{n_1}{n_2}$$

1.3 Determine number of stages according to ratio requirement

2. Determine gear unit size

2.1 Compare required power with gear unit nominal rating

$$P_N \geq P_e \times f_1 \times f_3$$

2.2 Check Starting / Maximum torque

$$T_{max} \leq 9550 \times \frac{P_N}{n_1} \times f_2 \times f_4$$

3. Check Thermal rating

3.1 Gear unit without auxiliary cooling

$$P_e \leq P_{T1} \times f_w \times f_5 \times f_6$$

3.2 Gear unit with fan cooling

$$P_e \leq P_{T2} \times f_w \times f_5 \times f_6$$

3.3 Gear unit with built in cooling coil

$$P_e \leq P_{T3} \times f_w \times f_5 \times f_6$$

3.4 Gear unit with built in cooling coil & single fan

$$P_e \leq P_{T4} \times f_w \times f_5 \times f_6$$

Thermal rating of external oil-cooler are
ON REQUEST

i_N	Nominal Transmission ratio
n_1	Input speed, rpm
n_2	Output speed, rpm
P_N	Nominal power rating, kW
P_e	Absorbed Power of the connected machine, kW
f_1	Application factor (Table 1)
f_2	Operating frequency factor (Table 2)
f_3	Prime mover factor (Table 3)
f_4	Reversal factor (Table 4)
f_5	Altitude factor (Table 6)
f_6	Maximaum oil sump tamp. factor (Table 7)
T_{max}	Start up or maximum motor torque, Nm
f_w	Ambient temperature factors (Table 5)
P_{T1}	Thermal rating without additional cooling, kW
P_{T2}	Thermal rating with fan cooling, kW
P_{T3}	Thermal rating with Built-in cooling coil, kW
P_{T4}	Thermal rating with Built in cooling coil + fan cooling, kW
ED	Duty cycle per hour, %

Thermal Rating given in tables are calculated based on following assumptions

1. Gear unit with mineral oil ISO VG 320
2. Duty cycle, ED: 100%
3. Ambient temperature: 20°C
4. Installation in large hall, wind velocity ≥ 1.4 m/s
5. Altitude : sea level
6. Gear unit with splash lubrication
7. Oil sump temperature 95°C

Example

Given data

Application: Bucket Conveyor	Daily operating time: 24 hrs/day
Electric motor power: 500 kW	Starts per hour: 1
Motor speed: 1500 rpm	Duty cycle, ED: 100%
Motor starting torque $T_{max} = 6370$ Nm	Ambient temperature: 40°C
Required output power: 350 kW	Installation: Outdoor
Gearbox output speed: 60 rpm	Gearbox type: Bevel-Helical
Altitude : 1000m.	Load: Steady direction

1. Determination of gear unit type and stage

- 1.1 Foot Mount Bevel-Helical Gearbox
- 1.2 Determine required transmission ratio

$$i_N = \frac{n_1}{n_2} = \frac{1500}{60} \quad i_N = 25:1$$

1.3 3 stage Bevel-Helical Gearbox

2. Determine gear unit size

$$P_N \geq P_e \times f_1 \times f_3 = 350 \times 1.5 \times 1$$

$P_N \geq 525$ (From power rating table of Bevel helical- Three stage, Select size "724" with $P_N = 573$ kW)

Check Starting torque

$$T_{max} \leq 9550 \times \frac{P_N}{n_1} \times f_2 \times f_4 = 9550 \times \frac{573}{1500} \times 2 \times 1 = 7296 \text{ Nm}$$

$$T_{max} = 6370 \text{ Nm} \leq 7296 \text{ Nm, OK.}$$

3. Check Thermal rating

3.1 For Gear unit without auxiliary cooling, $f_w = 0.75$, $f_5 = 0.9$ (as per given DATA)

$$P_e \leq P_{T1} \times f_w \times f_5 \times f_6 \leq 292 \times 0.75 \times 0.9 \times 1$$

$$350 \not\leq 197.1$$

i.e. Additional cooling required

3.2 Gear unit with fan cooling

$$P_e \leq P_{T2} \times f_w \times f_5 \times f_6 \leq 508 \times 0.8 \times 0.9 \times 1$$

$$350 \leq 365$$

i.e. Additional Fan cooling is required

Appropriate Gearbox is B3-724, $i_N=25:1$ with Fan cooling

3.2 Equivalent power with load spectrum

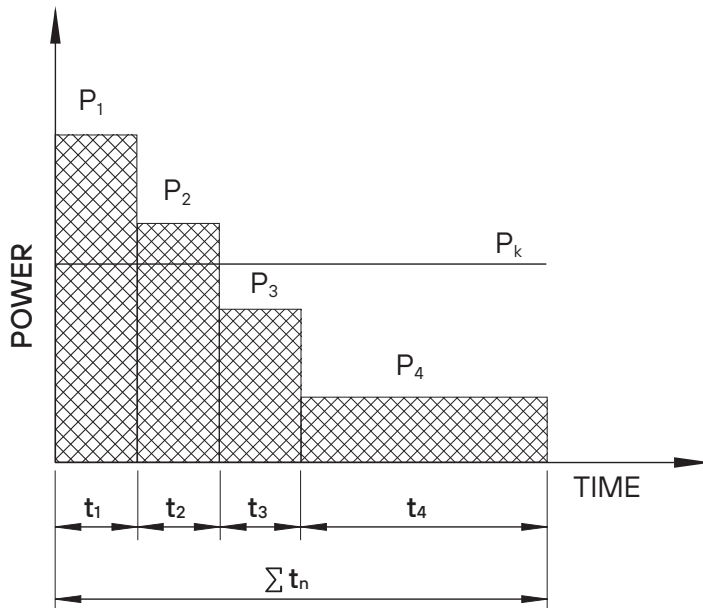

For finding Equivalent power in case of alternating loads within representative periods of time t is calculated by

$$P_k = \sqrt[6.6]{P_1^{6.6} \times \frac{t_1}{100} + P_2^{6.6} \times \frac{t_2}{100} + \dots + P_n^{6.6} \times \frac{t_n}{100}}$$

Where,

P_k : Equivalent Power, kW

P_1, P_2, P_3 : Individual Power fractions, kW

t_1, t_2, t_3 : Individual time period, in %

Example

Given data

Application: Bucket Conveyor	$P_1 = 169$ kW at 20% of time
Electric motor power: 500 kW	$P_2 = 205$ kW at 40% of time
Motor speed: 1500 rpm	$P_3 = 295$ kW at 30% of time
Required output power: 350 kW	$P_4 = 445$ kW at 10% of time
Gearbox output speed: 60 rpm	
Starts per hour: 1	
Duty cycle, ED: 60%	
Ambient temperature: 40°C	
Installation: Outdoor	
Gearbox type: Bevel-Helical	
Load: Steady direction	

Determine gear unit size

$$P_k = \sqrt[6.6]{P_1^{6.6} \times \frac{t_1}{100} + P_2^{6.6} \times \frac{t_2}{100} + \dots + P_n^{6.6} \times \frac{t_n}{100}}$$

$$P_k = 324 \text{ kW}$$

$$P_N \geq P_e \times f_1 \times f_3 = 324 \times 1.5 \times 1$$

$$P_N \geq 486 \text{ (From power rating table of Bevel helical - Three stage, Select size "723" with } P_N = 505 \text{ kW)}$$

3.3 Service factors

Table:1 GEAR UNIT APPLICATION FACTOR (f _i)	operating hours/day under load		
	≤ 0.5	0.5 - 10	> 10
BLOWER, FANS, VENTILATORS			
Axial blowers	1.5	1.5	1.5
Dry cooling towers	-	-	2
Wet cooling towers	2	2	2
Radial blowers	-	1.4	1.5
Heat exchangers	1.5	1.5	1.5
CABLE WAYS			
Material ropeways	-	1.4	1.5
CHEMICAL INDUSTRY			
Mixers (uniform media)	1	1.3	1.4
Mixers (Non-uniform media)	1.4	1.6	1.7
Agitators (pure liquid)	1	1.3	1.5
Agitators (liquid and solid)	1.2	1.4	1.6
Agitators (liquid with various densities)	1.2	1.5	1.65
Agitators (with variable gas absorb)	1.4	1.6	1.8
Agitators for solids (non-uniform metal)	1.4	1.6	1.8
Agitators for solids (uniform metal)	-	1.35	1.4
Centrifuges (light and heavy)	1	1.2	1.3
Toaster	1	1.3	1.5
Extruders	-	-	1.6
Dough mills	-	1.8	1.8
Rubber calenders	-	1.5	1.5
Cooling drums	-	1.3	1.4
COMPRESSORS			
Rotary compressor	-	1.4	1.5
Reciprocating compressor	-	1.8	1.9
Screw type compressor	-	1.5	1.75
CONVEYING PLANTS			
Bucket conveyor	-	1.4	1.5
Apron conveyors	-	1.25	1.5
Conveyors systems	-	1.5	1.8
Apron conveyors	-	1.2	1.5
Belt conveyors (<150kw)	1	1.2	1.3
Belt conveyors (>=150kw)	1.1	1.3	1.4
Screw feeders	1.15	1.25	1.5
Escalators	1	1.2	1.4
Shakers, screens	1.55	1.75	2
Passenger lift	-	1.5	1.8
Goods lifts	-	1.2	1.5
CRANES			
Acc. To FEM 1001, Refer ELECON crane duty gearbox catalogue			
EXCAVATORS AND STACKERS			
Travelling gear (caterpillar track)	1.2	1.6	1.8
Bucket wheel (As pick up)	-	1.7	1.7
Bucket wheel (For primitive material)	-	2.2	2.2
Slewing machines	-	1.55	1.8
Dumping devices	-	1.3	1.5
Swing gear	-	1.4	1.8
Cutter heads	-	2.2	2.2
FOODSTUFF MACHINES			
Sugarcane crusher and mills	-	-	1.75
Beet sugar slicing machines	-	1.25	1.5
Drying drums	-	1.25	1.5
Beet cossettes macerators	-	-	1.2
GENERATORS			
Frequency convertor	-	1.8	2
METAL WORKING			
Winder	-	1.6	1.75
Cutting rollers	1.55	1.75	2
Wire drawing machines	1.35	1.5	1.6

Table:1 GEAR UNIT APPLICATION FACTOR (f _i)	operating hours/day under load		
	≤ 0.5	0.5 - 10	> 10
Winding machines	-	1.6	1.6
MILLS			
Ball mills	-	-	2.5
Cooling and drying drums	-	1.5	1.6
Rotary kilns	-	-	2
Coal mill	-	1.5	1.75
Reversing blooming mills	-	2.5	2.5
Reversing plate mills	-	1.8	1.8
Reversing sheets mills	-	2	2
Reversing wire mills	-	1.8	1.8
MINING, ROCK, EARTH			
Crusher (Rotary crushers)	2.3	2.7	3
Screens and shakers	1.55	1.75	2
PAPER MACHINES			
Calenders	-	1.8	2
Presses glue	-	-	1.75
Drying cylinders	-	1.8	2
Rolls (wire suction, wire drive)	-	1.8	2
Filters (vacuum & pressure)	-	1.8	2
Beater and chipper	1.55	1.75	2
Washer filters	-	-	1.5
Jordan mills	-	1.5	1.75
PUMPS			
Centrifugal pump (light liquid)	1.15	1.35	1.45
Reciprocating pump(1 cylinder)	1.35	1.5	1.8
Reciprocating pump(multi cylinder)	1.2	1.4	1.5
Screw pumps	-	1.25	1.5
Rotary pumps	-	-	1.25
Charge pump	1.5	1.75	2
RUBBER AND PLASTICS			
Extruders(rubber)	-	1.5	1.8
Extruders(plastic)	-	1.4	1.6
Calenders	-	1.65	1.65
Mills(rubber) and rubber roller	1.55	1.75	2
Kneading machines	-	-	1.8
Heated rollers	1.35	1.5	1.75
Slab rollers	1.55	1.75	2
Refiners	1.55	1.75	2
WATER TREATMENT			
Thickeners(Central Drive)	-	-	1.2
Aerators(Rotary aerators)	-	1.8	2
Ranking equipment	1	1.2	1.3
Flocculation apparatus	0.8	1	1.3
Pre-Thickeners	-	1.1	1.3
Combined longitudinal and rotary racks	1	1.3	1.5
Water turbines	-	-	2
Water screw pumps	-	1.3	1.5
Filter presses	1	1.3	1.5
Accumulators	1.15	1.25	1.5
Brush aerators	-	-	2
Centrifugal pump	1	1.2	1.3
Displacement pump(1 piston)	1.3	1.4	1.8
Displacement pump(>1 piston)	1.2	1.4	1.5

NOTE: all gear unit application factors are gained from experience

3.3 Service factors

Load peaks per hour					
1	2-10	11-20	21-50	51-100	>100
2	1.6	1.4	1.2	1.1	1

Electric motors / Turbine	Piston Engines 4-6 Cylinder, Cyclic variation > 1:100-1:200	Piston Engines 1-3 Cylinder, Cyclic variation < 1:100
1	1.25	1.5

Steady direction of load	Alternating Direction of load	Reversing operation
1	0.85	0.7

Altitude (m)	Factor (f_5)
Sea level	1
750	0.95
1500	0.9
2250	0.85
3000	0.81
3750	0.77
4500	0.72
5250	0.68

Max. oil sump temperature (°C)	Factor (f_6)
85	0.75
90	0.85
95	1

Type of cooling	Ambient temp.	Duration of operation per hour				
		100%	80%	60%	40%	20%
for gearboxes without additional cooling	10°C	1.12	1.34	1.57	1.79	2.05
	20°C	1	1.2	1.4	1.6	1.8
	30°C	0.88	1.06	1.23	1.41	1.58
	40°C	0.75	0.9	1.05	1.2	1.35
for gearboxes with fan cooling	10°C	1.15	1.38	1.61	1.84	2.07
	20°C	1	1.2	1.4	1.6	1.8
	30°C	0.9	1.08	1.26	1.44	1.62
	40°C	0.8	0.96	1.12	1.29	1.44
for gearboxes with cooling coil	10°C	1.1	1.32	1.54	1.76	1.98
	20°C	1	1.2	1.4	1.6	1.8
	30°C	0.9	1.08	1.26	1.44	1.62
	40°C	0.85	1.02	1.19	1.36	1.53
for gearboxes with cooling coil + fan	10°C	1.12	1.34	1.57	1.79	2.05
	20°C	1	1.2	1.4	1.6	1.8
	30°C	0.92	1.1	1.29	1.47	1.66
	40°C	0.93	1	1.16	1.33	1.5
for gearboxes with cooling coil	50°C	0.8	0.96	1.12	1.29	1.44
	50°C	0.7	0.84	0.98	1.12	1.26
	50°C	0.78	0.94	1.09	1.25	1.4
	50°C	0.8	0.96	1.12	1.29	1.44

3.4 Data tables – Type H1

Nominal power rating P_N (kW)

i_N	n1	n2	Gear unit size													
			712	713	714	715	716	717	718	719	720	721	722	723	724	725
1.25	1500	1200	102	167	390	758	1212		2465 *		3034 *		5119 *			
	1000	800	68	112	260	505	808		1643		2023		3413 *			
	750	600	51	84	195	379	606		1233		1517		2559			
1.4	1500	1071	89	155	386	681	1127		2158		2944 *		4555 *			
	1000	714	59	103	258	454	751		1439		1963		3037			
	750	536	44	77	193	341	563		1079		1472		2277			
1.6	1500	938	79	132	338	591	962		1931		2677 *		4931 *		6757 *	
	1000	625	53	88	226	394	641		1287		1785		3287		4505 *	
	750	469	39	66	169	296	481		965		1338		2466		3379	
1.8	1500	833	71	118	302	646	862		1659		2552 *		4363 *		6341 *	6741 *
	1000	556	48	79	202	431	575		1106		1702		2909		4227	4494 *
	750	417	36	59	151	323	431		830		1276		2182		3171	3371
2	1500	750	63	107	262	577	771		1531		2645		3853 *		6081 *	6847 *
	1000	500	42	72	175	384	514		1021		1763		2568		4054	4565
	750	375	31	54	131	288	385		766		1322		1926		3041	3424
2.24	1500	670	57	95	243	512	754		1355		2338		3490 *		5426 *	6211 *
	1000	446	38	63	162	341	503		903		1558		2327		3617	4141
	750	335	28	47	121	256	377		677		1169		1745		2713	3106
2.5	1500	600	51	88	225	461	697		1191		2054		3226 *		4944 *	5738 *
	1000	400	34	59	150	307	465		794		1369		2150		3296	3825
	750	300	26	44	112	230	349		596		1027		1613		2472	2869
2.8	1500	536	44	77	201	404	615		1058		1824		2843		4361 *	5161 *
	1000	357	30	51	134	269	410		705		1216		1896		2907	3441
	750	268	22	39	100	202	307		529		912		1422		2180	2580
3.15	1500	476	41	62	183	346	538		992		1649		2487		3767	4616 *
	1000	317	27	41	122	231	359		661		1099		1658		2511	3077
	750	238	21	31	92	173	269		496		825		1243		1884	2308
3.55	1500	423	36	57	157	303	474		910		1470		2189		3511	4101 *
	1000	282	24	38	105	202	316		607		980		1459		2341	2734
	750	211	18	29	79	151	237		455		735		1094		1756	2050
4	1500	375	31	50	139	287	438		825		1277		1940		3060	3613
	1000	250	21	34	93	191	292		550		851		1294		2040	2408
	750	188	15	25	70	143	219		412		639		970		1530	1806
4.5	1500	333	28	42	117	230	310		600		913		1578		2203	3190
	1000	222	19	28	78	154	207		400		609		1052		1468	2126
	750	167	14	21	59	115	155		300		456		789		1101	1595
5	1500	300	18	36	99	189	279		508		721		1253		1832	2684
	1000	200	12	24	66	126	186		339		481		835		1221	1789
	750	150	9.2	18	50	95	140		254		361		626		916	1342
5.6	1500	268	20	31	64	170	260		439		574		1032		1618	2267
	1000	179	13	21	43	113	173		293		383		688		1078	1511
	750	134	10	15	32	85	130		220		287		516		809	1133

* Required force lubrication

3.4 Data tables – Type H1

Nominal output torque of low speed shaft, (kNm)

Type	i _n	Gear unit size														
		712	713	714	715	716	717	718	719	720	721	722	723	724	725	
H1	1.25	0.8	1.37	3.1	6.1	9.7		19.5		24		41				
	1.4	0.8	1.4	3.5	6.1	10		19.5		26		41				
	1.6	0.8	1.4	3.5	6.1	10		19.5		28		50		68		
	1.8	0.8	1.4	3.5	7.2	10		19.5		30		50		71	77	
	2	0.8	1.4	3.5	7.2	10		19.5		33		50		76	90	
	2.24	0.8	1.4	3.5	7.2	11		19.5		33		50		76	90	
	2.5	0.8	1.4	3.5	7.2	11		19.5		33		50		78	92	
	2.8	0.8	1.4	3.5	7.2	11		19.5		33		50		78	92	
	3.15	0.8	1.27	3.5	7.1	11		20		33		50		77	92	
	3.55	0.8	1.29	3.5	6.9	11		21		33		50		77	92	
	4	0.8	1.3	3.5	7.2	11		21		33		50		77	92	
	4.5	0.8	1.25	3.3	6.6	9		17.4		26		46		62	88	
	5	0.6	1.15	3	6.1	9		16		23.5		39		59	83	
	5.6	0.7	1.14	2.28	6.1	9		15.8		20.1		37		56	79	
H2	6.3			3.3		11.4		20.4		34		60.8		86.4		
	7.1			3.3		11.4		20.4		34		60.8		86.4		
	8			3.3	6.8	11.4	14.4	20.4	25.9	34	43.0	60.8	76.0	86.4	110	
	9			3.3	6.8	11.4	14.4	20.4	25.9	34	43.5	60.8	76.0	86.4	110	
	10			3.3	6.8	11.4	14.4	20.4	25.9	34	43.5	60.8	76.0	86.4	110	
	11.2			3.3	6.8	11.4	14.4	20.4	25.9	34	43.5	60.8	76.0	86.4	110	
	12.5			3.3	6.8	11.4	14.4	20.4	25.9	34	43.5	60.8	76.0	86.4	110	
	14			3.3	6.8	11.4	14.4	20.4	25.9	34	43.5	60.8	76.0	86.4	110	
	16			3.3	6.8	11.4	14.4	20.4	25.9	34	43.5	60.8	76.0	86.4	110	
	18			3.3	6.8	11.1	14.4	20.4	25.9	34	43.5	60.8	76.0	86.4	110	
	20			3.4	6.8	11.6	14.4	20	25.9	35.7	43.5	63.6	76.0	90	110	
	22.4			3.4	6.8	11.6	14	20	25.9	35.7	43.5	63.6	76.0	90	110	
H3	25			3.4	5.5	11.6	15.5	21.7	25	35.7	44.1	63.6	78	90	114	
	28			3.4	5.9	11.6	15.5	21.7	25	35.7	44.1	63.6	78	90	114	
	31.5			3.4	6	11.6	15.3	21.7	26.3	35.7	44.1	63.6	78	90	114	
	35.5			3.4	6	11.6	15.5	21.7	24.8	35.7	44.1	63.6	78	90	114	
	40			3.4	6	11.6	15.5	21.7	27.3	35.7	44.1	63.6	78	90	114	
	45			3.4	6	11.6	15.5	21.7	27.3	35.7	44.1	63.6	78	90	114	
	50			3.4	6	11.6	15.5	21.7	27.3	35.7	44.1	63.6	78	90	114	
	56			3.4	6	11.6	15.5	21.7	25.9	35.7	44.1	63.6	78	90	114	
	63			3.4	6	11.6	15.5	21.7	27.3	35.7	44.1	63.6	78	90	114	
	71			3.4	6	11.6	15.5	21.7	27.3	35.7	44.1	63.6	78	90	114	
	80				6	11.6	15.5	21.7	27.3	35.9	44.1	63.6	78	91	114	
90				6	11.6	15.5	21.7	26.5	35.9	44.1	63.6	78	91	114		
H4	100					11.6	15.5	21.7	25.5	35.9	44.4	63.6	78	91	115	
	112					11.6	15.5	21.7	27.3	35.9	44.4	63.6	78	91	115	
	125					11.6	15.5	21.7	27.3	35.9	44.4	63.6	78	91	115	
	140					11.6	15.5	21.7	26.3	35.9	44.4	63.6	78	91	115	
	160					11.6	15.5	21.7	27.3	35.9	44.4	63.6	78	91	115	
	180					11.6	15.5	21.7	27.3	35.9	44.4	63.6	78	91	115	
	200					11.6	15.5	21.7	27.3	35.9	44.4	63.6	78	91	115	
	224					11.6	15.5	21.7	27.3	35.9	44.4	63.6	78	91	115	
	250					11.6	15.5	21.7	27.3	35.9	44.4	63.6	78	91	115	
	280					11.6	15.5	21.7	27.3	35.9	44.4	63.6	78	91	115	
	315					11.6	15.5	21.7	27.3	35.9	44.4	63.6	78	91	115	
	355					11.6	15.5	21.7	25.2	35.9	44.4	63.6	78	91	115	
	400							15.5		27.3		44.4		78		115
	450							15.5		25.4		44.4		78		115

3.4 Data tables – Type H1

Thermal capacity (kW), n1 = 750 RPM

i _N		Gear unit size													
		712	713	714	715	716	717	718	719	720	721	722	723	724	725
1.25	P _{T1}	33	48	78	130										
	P _{T2}	41	68	94	158	215		348		471		529			
	P _{T3}					469		560		1068		929			
	P _{T4}					533		674		1205		1110			
1.4	P _{T1}	32	48	81	129	152									
	P _{T2}	40	67	98	156	216		355		495		597			
	P _{T3}					470		571		1124		1048			
	P _{T4}					534		688		1267		1252			
1.6	P _{T1}	31	46	78	125	148									
	P _{T2}	39	64	94	151	210		353		488		652			
	P _{T3}					457		568		1108		1145		1208	
	P _{T4}					520		684		1249		1368		1347	
1.8	P _{T1}	30	44	74	132	144									
	P _{T2}	37	62	90	160	205		332		493		648			
	P _{T3}					446		534		1117		1138		1227	
	P _{T4}					507		644		1260		1361		1349	
2	P _{T1}	28	42	69	128	139									
	P _{T2}	35	59	83	156	198		329		504		649		800	
	P _{T3}					431		529		1143		1140		1268	
	P _{T4}					490		638		1289		1363		1414	
2.24	P _{T1}	29	42	78	131	147									
	P _{T2}	34	55	88	149	196		316		488		653		800	
	P _{T3}					436		521		1131		1175		1312	
	P _{T4}					485		612		1250		1370		1415	
2.5	P _{T1}	30	41	75	124	145									
	P _{T2}	34	54	85	141	194		299		468		651		802	
	P _{T3}					430		495		1085		1171		1315	
	P _{T4}					479		580		1198		1365		1419	
2.8	P _{T1}	27	42	76	120	138									
	P _{T2}	31	54	85	133	181		273		441		635		790	
	P _{T3}					405		456		1028		1151		1309	
	P _{T4}					447		530		1128		1331		1397	
3.15	P _{T1}	26	36	71	107	143									
	P _{T2}	33	51	87	131	206		301		471		661		804	
	P _{T3}					446		481		1066		1155		1268	
	P _{T4}					508		583		1206		1387		1422	
3.55	P _{T1}	25	35	65	105	133									
	P _{T2}	32	49	79	129	191		286		442		613		791	
	P _{T3}					414		458		1000		1072		1247	
	P _{T4}					472		554		1131		1287		1399	
4	P _{T1}	24	33	64	100	133									
	P _{T2}	30	47	78	123	191		297		409		661		828	
	P _{T3}					415		476		925		1156		1306	
	P _{T4}					473		576		1046		1387		1464	
4.5	P _{T1}	27	39	72	99	132									
	P _{T2}	31	49	79	109	170		325		450		636		798	
	P _{T3}					382		543		1052		1158		1331	
	P _{T4}					421		629		1150		1334		1412	
5	P _{T1}	25	36	66	95	130									
	P _{T2}	28	46	73	104	168		321		403		608		734	
	P _{T3}					377		537		942		1107		1224	
	P _{T4}					416		622		1030		1276		1299	
5.6	P _{T1}	25	37	62	90	123									
	P _{T2}	29	48	69	99	160		288		375		576		702	
	P _{T3}					358		482		878		1048		1170	
	P _{T4}					395		558		960		1208		1242	

3.4 Data tables – Type H1

Thermal capacity (kW), n1 = 1000 RPM

i _N		Gear unit size													
		712	713	714	715	716	717	718	719	720	721	722	723	724	725
1.25	P _{T1}	32	47	76	128										
	P _{T2}	60	84	140	234	274		516		556					
	P _{T3}					466		555		1062					
	P _{T4}					591		842		1290					
1.4	P _{T1}	32	47	79	126	149									
	P _{T2}	59	83	145	231	274		526		585					
	P _{T3}					467		567		1117					
	P _{T4}					592		859		1357					
1.6	P _{T1}	31	45	76	122	145									
	P _{T2}	58	80	140	224	267		523		576					
	P _{T3}					455		563		1101		1141		1202	
	P _{T4}					577		854		1337		1521		1525	
1.8	P _{T1}	29	43	73	129	141									
	P _{T2}	55	76	133	237	260		492		581		801			
	P _{T3}					443		530		1111		1134		1221	1341
	P _{T4}					562		804		1349		1513		1550	1736
2	P _{T1}	28	41	67	126	137									
	P _{T2}	52	73	123	230	252		488		595		802			
	P _{T3}					429		525		1136		1136		1262	1397
	P _{T4}					544		796		1380		1515		1602	1808
2.24	P _{T1}	28	41	76	129	144		221							
	P _{T2}	50	68	131	221	249		467		577		806		987	1214
	P _{T3}					433		517		1124		1170		1305	1473
	P _{T4}					538		763		1338		1523		1603	1838
2.5	P _{T1}	29	40	74	122	142		210		348					
	P _{T2}	51	67	126	209	246		443		553		804		990	1234
	P _{T3}					428		490		1078		1166		1309	1498
	P _{T4}					531		724		1283		1518		1607	1870
2.8	P _{T1}	27	41	75	118	136		195		334		449			
	P _{T2}	46	66	125	198	229		405		520		783		975	1236
	P _{T3}					402		452		1021		1146		1302	1518
	P _{T4}					496		661		1207		1480		1582	1873
3.15	P _{T1}	26	35	70	105	140		195		325		425			
	P _{T2}	49	63	129	194	261		446		556		816		993	1229
	P _{T3}					443		478		1059		1151		1262	1430
	P _{T4}					564		728		1291		1542		1611	1862
3.55	P _{T1}	25	34	63	103	130		186		305		395		633	
	P _{T2}	47	61	117	190	242		423		522		757		976	1211
	P _{T3}					411		454		994		1068		1241	1408
	P _{T4}					524		692		1211		1431		1584	1834
4	P _{T1}	24	33	63	98	130		193		282		426		662	764
	P _{T2}	45	58	116	182	243		440		483		816		1022	1178
	P _{T3}					412		472		919		1152		1299	1371
	P _{T4}					525		719		1120		1542		1658	1785
4.5	P _{T1}	27	38	70	97	129		234		344		455		710	875
	P _{T2}	46	61	117	162	216		481		531		785		986	1214
	P _{T3}					380		539		1045		1153		1324	1500
	P _{T4}					467		785		1231		1483		1600	1839
5	P _{T1}	25	35	65	93	127		232		308		435		653	923
	P _{T2}	42	56	108	154	213		476		475		751		907	1281
	P _{T3}					375		533		935		1103		1218	1582
	P _{T4}					461		777		1103		1418		1471	1940
5.6	P _{T1}	25	37	61	88	121		208		287		412		624	863
	P _{T2}	42	59	102	147	203		427		443		711		867	1198
	P _{T3}					356		478		872		1044		1164	1480
	P _{T4}					438		697		1028		1343		1406	1816

3.4 Data tables – Type H1

Thermal capacity (kW), n1 = 1500 RPM

i _N		Gear unit size													
		712	713	714	715	716	717	718	719	720	721	722	723	724	725
1.25	P _{T1}														
	P _{T2}	68	95	158	265	310		584							
	P _{T3}					461		548							
	P _{T4}					627		911		1327					
1.4	P _{T1}	31													
	P _{T2}	67	94	164	262	311		596							
	P _{T3}					462		559							
	P _{T4}					629		930		1396					
1.6	P _{T1}	30	44												
	P _{T2}	65	90	158	253	302		593		615					
	P _{T3}					450		556		1091		1132			
	P _{T4}					612		924		1376		1790		1839	
1.8	P _{T1}	29	42												
	P _{T2}	62	87	151	268	295		558		620					
	P _{T3}					439		523		1100		1125			
	P _{T4}					597		869		1388		1780		1868	2118
2	P _{T1}	27	40												
	P _{T2}	59	83	139	261	285		553		635		1069			
	P _{T3}					424		518		1126		1127			
	P _{T4}					577		861		1420		1782		1931	2205
2.24	P _{T1}	26	38												
	P _{T2}	56	78	148	250	282		530		615		1075			
	P _{T3}					420		497		1091		1133			
	P _{T4}					571		826		1376		1792		1932	2243
2.5	P _{T1}	26	37	67											
	P _{T2}	58	76	143	236	279		503		590		1071			
	P _{T3}					415		472		1046		1129			
	P _{T4}					564		783		1320		1786		1937	2281
2.8	P _{T1}	24	36	66											
	P _{T2}	52	75	142	224	260		459		555		1045			
	P _{T3}					387		430		985		1101		1233	1430
	P _{T4}					526		715		1242		1741		1907	2285
3.15	P _{T1}	25	35	68											
	P _{T2}	55	72	146	220	296		505		594		1088		1324	
	P _{T3}					440		474		1053		1147		1256	1422
	P _{T4}					599		787		1328		1814		1942	2272
3.55	P _{T1}	24	33	62	101										
	P _{T2}	53	69	133	216	275		480		557		1010		1301	
	P _{T3}					409		450		988		1064		1235	1401
	P _{T4}					556		748		1246		1683		1909	2238
4	P _{T1}	23	32	61	96										
	P _{T2}	51	66	131	206	275		499		515		1088		1362	
	P _{T3}					410		468		914		1147		1292	1363
	P _{T4}					557		778		1152		1814		1999	2178
4.5	P _{T1}	24	33	62	86	114		207		304				633	779
	P _{T2}	52	69	132	183	245		545		566		1047		1314	1619
	P _{T3}					365		511		1004		1103		1247	1404
	P _{T4}					496		849		1267		1745		1928	2244
5	P _{T1}	22	31	57	82	112		204		272					
	P _{T2}	48	64	122	175	242		539		507		1001		1209	1708
	P _{T3}					360		506		899		1055		1147	1482
	P _{T4}					489		840		1134		1669		1774	2367
5.6	P _{T1}	22	32	54	78	107		184		254					
	P _{T2}	48	67	115	167	230		484		473		948		1155	1598
	P _{T3}					342		454		838		999		1096	1386
	P _{T4}					465		754		1058		1580		1695	2215

3.5 Data tables – Type H2

Nominal power rating P_N (kW)

i_N	n1	n2	Gear unit size													
			712	713	714	715	716	717	718	719	720	721	722	723	724	725
6.3	1500	238			79		270		528		817		1466		2100	
	1000	159			53		180		352		545		977		1400	
	750	119			40		135		264		409		733		1050	
7.1	1500	211			72		234		471		733		1353		1978	
	1000	141			48		156		314		489		902		1319	
	750	106			36		117		235		366		676		989	
8	1500	188			64	127	217	271	418	527	655	837	1197	1466	1749	2127
	1000	125			43	85	145	181	279	351	437	558	798	977	1166	1418
	750	94			32	64	108	136	209	263	327	418	598	733	874	1063
9	1500	167			59	116	201	235	376	470	583	759	1052	1353	1536	2003
	1000	111			39	77	134	156	251	313	388	506	701	902	1024	1336
	750	83			30	58	100	117	188	235	291	380	526	676	768	1002
10	1500	150			52	102	179	218	330	418	539	678	935	1197	1364	1771
	1000	100			35	68	120	145	220	278	359	452	623	798	909	1181
	750	75			26	51	90	109	165	209	269	339	467	598	682	885
11.2	1500	134			46	95	164	202	287	376	475	603	854	1052	1234	1556
	1000	89			31	63	109	134	191	250	317	402	570	701	822	1037
	750	67			23	47	82	101	143	188	238	302	427	526	617	778
12.5	1500	120			42	83	140	180	258	329	416	558	746	935	1100	1382
	1000	80			28	56	94	120	172	220	277	372	498	623	733	921
	750	60			21	42	70	90	129	165	208	279	373	467	550	691
14	1500	107			36	74	125	164	234	286	366	492	676	854	955	1249
	1000	71			24	49	83	110	156	191	244	328	451	570	637	833
	750	54			18	37	62	82	117	143	183	246	338	427	478	625
16	1500	94			32	67	111	141	205	258	338	431	594	746	867	1114
	1000	63			21	45	74	94	137	172	226	287	396	498	578	742
	750	47			16	34	56	70	103	129	169	215	297	373	433	557
18	1500	83			29	58	101	125	183	234	293	379	547	676	758	967
	1000	56			20	39	67	83	122	156	195	253	365	451	505	645
	750	42			15	29	50	63	91	117	146	190	273	338	379	484
20	1500	75				51		112		205		351		594		878
	1000	50				34		74		137		234		396		585
	750	38				26		56		102		175		297		439
22.4	1500	67				47		101		182		303		547		767
	1000	45				31		67		122		202		365		512
	750	33				23		50		91		152		273		384

3.5 Data tables – Type H2

Nominal output torque of low speed shaft, (kNm)

Type	i _N	Gear unit size													
		712	713	714	715	716	717	718	719	720	721	722	723	724	725
H1	1.25	0.8	1.37	3.1	6.1	9.7		19.5		24		41			
	1.4	0.8	1.4	3.5	6.1	10		19.5		26		41			
	1.6	0.8	1.4	3.5	6.1	10		19.5		28		50		68	
	1.8	0.8	1.4	3.5	7.2	10		19.5		30		50		71	77
	2	0.8	1.4	3.5	7.2	10		19.5		33		50		76	90
	2.24	0.8	1.4	3.5	7.2	11		19.5		33		50		76	90
	2.5	0.8	1.4	3.5	7.2	11		19.5		33		50		78	92
	2.8	0.8	1.4	3.5	7.2	11		19.5		33		50		78	92
	3.15	0.8	1.27	3.5	7.1	11		20		33		50		77	92
	3.55	0.8	1.29	3.5	6.9	11		21		33		50		77	92
	4	0.8	1.3	3.5	7.2	11		21		33		50		77	92
	4.5	0.8	1.25	3.3	6.6	9		17.4		26		46		62	88
	5	0.6	1.15	3	6.1	9		16		23.5		39		59	83
	5.6	0.7	1.14	2.28	6.1	9		15.8		20.1		37		56	79
H2	6.3			3.3		11.4		20.4		34		60.8		86.4	
	7.1			3.3		11.4		20.4		34		60.8		86.4	
	8			3.3	6.8	11.4	14.4	20.4	25.9	34	43.0	60.8	76.0	86.4	110
	9			3.3	6.8	11.4	14.4	20.4	25.9	34	43.5	60.8	76.0	86.4	110
	10			3.3	6.8	11.4	14.4	20.4	25.9	34	43.5	60.8	76.0	86.4	110
	11.2			3.3	6.8	11.4	14.4	20.4	25.9	34	43.5	60.8	76.0	86.4	110
	12.5			3.3	6.8	11.4	14.4	20.4	25.9	34	43.5	60.8	76.0	86.4	110
	14			3.3	6.8	11.4	14.4	20.4	25.9	34	43.5	60.8	76.0	86.4	110
	16			3.3	6.8	11.4	14.4	20.4	25.9	34	43.5	60.8	76.0	86.4	110
	18			3.3	6.8	11.1	14.4	20.4	25.9	34	43.5	60.8	76.0	86.4	110
	20			3.4	6.8	11.6	14.4	20	25.9	35.7	43.5	63.6	76.0	90	110
	22.4			3.4	6.8	11.6	14	20	25.9	35.7	43.5	63.6	76.0	90	110
H3	25			3.4	5.5	11.6	15.5	21.7	25	35.7	44.1	63.6	78	90	114
	28			3.4	5.9	11.6	15.5	21.7	25	35.7	44.1	63.6	78	90	114
	31.5			3.4	6	11.6	15.3	21.7	26.3	35.7	44.1	63.6	78	90	114
	35.5			3.4	6	11.6	15.5	21.7	24.8	35.7	44.1	63.6	78	90	114
	40			3.4	6	11.6	15.5	21.7	27.3	35.7	44.1	63.6	78	90	114
	45			3.4	6	11.6	15.5	21.7	27.3	35.7	44.1	63.6	78	90	114
	50			3.4	6	11.6	15.5	21.7	27.3	35.7	44.1	63.6	78	90	114
	56			3.4	6	11.6	15.5	21.7	25.9	35.7	44.1	63.6	78	90	114
	63			3.4	6	11.6	15.5	21.7	27.3	35.7	44.1	63.6	78	90	114
	71			3.4	6	11.6	15.5	21.7	27.3	35.7	44.1	63.6	78	90	114
	80				6	11.6	15.5	21.7	27.3	35.9	44.1	63.6	78	91	114
90				6	11.6	15.5	21.7	26.5	35.9	44.1	63.6	78	91	114	
H4	100					11.6	15.5	21.7	25.5	35.9	44.4	63.6	78	91	115
	112					11.6	15.5	21.7	27.3	35.9	44.4	63.6	78	91	115
	125					11.6	15.5	21.7	27.3	35.9	44.4	63.6	78	91	115
	140					11.6	15.5	21.7	26.3	35.9	44.4	63.6	78	91	115
	160					11.6	15.5	21.7	27.3	35.9	44.4	63.6	78	91	115
	180					11.6	15.5	21.7	27.3	35.9	44.4	63.6	78	91	115
	200					11.6	15.5	21.7	27.3	35.9	44.4	63.6	78	91	115
	224					11.6	15.5	21.7	27.3	35.9	44.4	63.6	78	91	115
	250					11.6	15.5	21.7	27.3	35.9	44.4	63.6	78	91	115
	280					11.6	15.5	21.7	27.3	35.9	44.4	63.6	78	91	115
	315					11.6	15.5	21.7	27.3	35.9	44.4	63.6	78	91	115
	355					11.6	15.5	21.7	25.2	35.9	44.4	63.6	78	91	115
	400							15.5		27.3		44.4		78	
450							15.5		25.4		44.4		78		115

3.5 Data tables – Type H2

Thermal capacity (kW), n1 = 750 RPM

i _N		Gear unit size													
		712	713	714	715	716	717	718	719	720	721	722	723	724	725
6.3	P _{T1}			41		91		165		230		400		520	
	P _{T2}			56		131		212		314		455		688	
	P _{T3}					214		323		536		718		837	
	P _{T4}					254		370		621		773		1005	
7.1	P _{T1}			39		84		158		223		393		516	
	P _{T2}			53		121		203		305		448		683	
	P _{T3}					198		310		520		707		830	
	P _{T4}					234		356		602		761		997	
8	P _{T1}			39	65	87	125	160	204	229	301	402	386	536	598
	P _{T2}			55	85	129	160	212	274	323	356	474	546	734	902
	P _{T3}					198	250	304	364	515	608	704	704	842	909
	P _{T4}					240	285	357	434	609	662	775	864	1040	1213
9	P _{T1}			42	64	86	119	156	204	227	305	397	395	536	616
	P _{T2}			58	82	124	148	201	264	309	348	452	539	709	898
	P _{T3}					193	235	293	358	501	604	684	709	832	926
	P _{T4}					231	264	337	418	583	647	739	854	1005	1208
10	P _{T1}			47	62	85	119	150	198	226	301	380	391	524	619
	P _{T2}			63	77	121	146	190	254	306	340	428	527	685	892
	P _{T3}					188	232	278	345	494	590	649	694	807	924
	P _{T4}					223	259	318	401	573	629	697	831	968	1196
11.2	P _{T1}			46	67	85	119	144	196	223	302	387	390	544	628
	P _{T2}			62	84	120	146	183	251	301	341	436	527	711	905
	P _{T3}					182	228	262	335	474	580	650	681	825	923
	P _{T4}					218	255	301	390	553	619	699	818	992	1200
12.5	P _{T1}			45	74	98	116	140	186	229	298	384	370	531	608
	P _{T2}			60	92	140	142	178	239	310	337	433	501	695	877
	P _{T3}					211	221	254	317	486	570	642	643	803	892
	P _{T4}					252	247	292	369	566	608	691	774	967	1161
14	P _{T1}			43	72	99	114	136	177	222	290	393	373	513	625
	P _{T2}			58	91	143	141	175	229	303	332	447	510	678	910
	P _{T3}					209	213	243	297	463	546	649	640	767	907
	P _{T4}					253	241	282	349	544	588	703	777	932	1193
16	P _{T1}			36	61	84	117	119	150	190	260	321	327	443	531
	P _{T2}			50	79	125	150	158	201	269	308	379	462	606	801
	P _{T3}					189	234	225	266	426	522	560	594	693	805
	P _{T4}					230	267	264	317	505	569	617	729	857	1075
18	P _{T1}			35	57	82	117	125	144	196	250	321	332	419	510
	P _{T2}			49	74	120	149	165	191	273	292	374	464	567	760
	P _{T3}					182	232	235	253	432	496	554	597	651	766
	P _{T4}					221	263	274	300	510	537	606	729	798	1016
20	P _{T1}				57		119		153		259		323		531
	P _{T2}				70		143		192		286		427		749
	P _{T3}						229		263		499		566		784
	P _{T4}						253		302		526		670		1002
22.4	P _{T1}				55		113		158		261		315		492
	P _{T2}				67		136		198		289		417		693
	P _{T3}						218		271		504		553		726
	P _{T4}						241		311		532		654		928

Thermal capacity for H2O/H2U (Full Oil) on request

3.5 Data tables – Type H2

Thermal capacity (kW), n1 = 1000 RPM

i _N		Gear unit size													
		712	713	714	715	716	717	718	719	720	721	722	723	724	725
6.3	P _{T1}			43		98		178		270		413		515	
	P _{T2}			69		161		261		353		544		663	
	P _{T3}					221		337		576		731		832	
	P _{T4}					284		420		659		863		979	
7.1	P _{T1}			41		90		171		262		406		511	
	P _{T2}			66		149		251		342		536		658	
	P _{T3}					204		323		559		720		825	
	P _{T4}					263		403		639		849		972	
8	P _{T1}			41	69	94	125	173	231	268	295	415	421	531	644
	P _{T2}			68	106	160	198	262	338	363	352	567	614	707	821
	P _{T3}					204	250	317	391	554	602	717	739	837	956
	P _{T4}					271	323	407	498	649	659	868	932	1013	1132
9	P _{T1}			43	65	90	115	163	223	257	289	396	416	513	641
	P _{T2}			71	101	153	183	248	326	347	344	540	607	683	817
	P _{T3}					196	231	300	377	531	588	683	730	809	951
	P _{T4}					260	298	384	480	621	643	828	921	979	1127
10	P _{T1}			47	62	88	114	155	214	254	282	375	407	496	637
	P _{T2}			78	95	149	180	235	313	343	337	512	594	660	812
	P _{T3}					190	227	283	361	521	571	644	711	779	942
	P _{T4}					252	293	363	460	610	626	781	898	943	1116
11.2	P _{T1}			44	65	83	109	142	203	239	271	366	389	492	619
	P _{T2}			77	104	149	181	226	310	337	338	522	594	685	824
	P _{T3}					181	218	260	342	491	549	628	680	773	914
	P _{T4}					246	289	344	449	589	615	784	885	966	1119
12.5	P _{T1}			43	70	96	105	137	191	243	265	359	366	476	593
	P _{T2}			75	114	173	176	220	295	347	333	518	564	670	798
	P _{T3}					208	210	251	321	500	536	617	639	748	877
	P _{T4}					285	280	334	425	604	605	776	837	941	1082
14	P _{T1}			39	66	94	100	129	176	228	250	356	357	445	591
	P _{T2}			72	112	176	174	216	283	340	328	535	574	653	829
	P _{T3}					204	199	236	296	469	506	612	624	700	873
	P _{T4}					286	274	323	403	581	584	791	841	907	1111
16	P _{T1}			37	64	90	117	128	169	223	255	332	357	439	573
	P _{T2}			62	98	154	186	195	248	302	304	453	521	584	730
	P _{T3}					196	234	234	286	459	517	570	623	689	846
	P _{T4}					259	302	301	364	538	566	691	787	834	1003
18	P _{T1}			36	59	86	115	133	159	224	240	324	354	406	537
	P _{T2}			60	92	148	184	203	236	306	289	447	523	546	692
	P _{T3}					187	229	242	268	461	485	557	619	637	793
	P _{T4}					249	298	313	345	543	534	680	787	778	948
20	P _{T1}				56		110		160		235		326		529
	P _{T2}				87		177		237		283		480		682
	P _{T3}						220		270		475		569		782
	P _{T4}						286		347		523		723		935
22.4	P _{T1}				53		105		165		237		318		490
	P _{T2}				83		168		244		286		469		631
	P _{T3}						209		278		480		555		724
	P _{T4}						273		357		529		707		865

Thermal capacity for H2O/H2U (Full Oil) on request

3.5 Data tables – Type H2

Thermal capacity (kW), n1 = 1500 RPM

i _N		Gear unit size													
		712	713	714	715	716	717	718	719	720	721	722	723	724	725
6.3	P _{T1}			48		98									
	P _{T2}			96		210		354		495		812		948	
	P _{T3}					221		322		554		701		795	
	P _{T4}					333		513		801		1130		1264	
7.1	P _{T1}			46		91		157		241					
	P _{T2}			91		194		340		480		799		941	
	P _{T3}					204		309		537		690		788	
	P _{T4}					308		493		777		1112		1254	
8	P _{T1}			43	63	89	113	149	200	232	256				
	P _{T2}			85	132	189	221	323	458	463	510	768	729	919	
	P _{T3}					199	238	294	360	518	562	664	686	770	
	P _{T4}					300	346	467	618	749	816	1070	1047	1225	
9	P _{T1}			45	60	85	104	141	192	222	250	346			
	P _{T2}			89	126	182	204	305	441	443	498	732	720	887	
	P _{T3}					191	220	278	347	496	549	633	678	744	
	P _{T4}					288	320	442	596	717	797	1020	1035	1184	
10	P _{T1}			49	56	82	102	132	183	217	241	324			
	P _{T2}			97	118	175	199	286	420	432	481	686	697	848	
	P _{T3}					184	215	260	330	484	530	593	655	711	
	P _{T4}					278	312	415	567	700	770	955	1000	1131	
11.2	P _{T1}			52	67	88	110	138	197	231	263	358	381	482	
	P _{T2}			92	123	167	191	264	398	407	462	669	667	843	
	P _{T3}					186	219	256	336	483	540	621	672	763	
	P _{T4}					264	299	381	537	659	740	932	957	1124	
12.5	P _{T1}			50	72	102	106	133	185	236	257	352	358	466	
	P _{T2}			88	133	192	184	254	374	415	451	657	626	815	
	P _{T3}					214	211	247	315	493	528	609	631	738	
	P _{T4}					304	288	368	505	672	723	915	899	1087	
14	P _{T1}			46	69	100	101	125	170	221	242	349	350	436	
	P _{T2}			81	126	188	175	239	344	389	426	652	611	762	
	P _{T3}					209	201	232	290	462	498	604	616	690	
	P _{T4}					298	274	346	465	630	682	907	878	1017	
16	P _{T1}			44	66	96	119	124	164	216	247	325	349	429	
	P _{T2}			77	121	180	205	237	332	381	435	607	611	751	
	P _{T3}					201	235	230	280	452	509	563	616	680	
	P _{T4}					286	322	343	448	617	697	845	877	1001	
18	P _{T1}			42	61	91	116	128	154	217	232	317	347	397	
	P _{T2}			74	112	172	201	245	312	382	409	593	606	694	
	P _{T3}					192	231	238	264	454	478	550	611	628	
	P _{T4}					273	315	355	422	619	654	825	871	926	
20	P _{T1}				58		112		155		227		319		
	P _{T2}				106		193		314		400		557		
	P _{T3}						221		265		468		562		
	P _{T4}						302		424		640		800		
22.4	P _{T1}				55		106		160		230		311		
	P _{T2}				101		184		323		404		544		
	P _{T3}						211		273		472		549		
	P _{T4}						288		437		647		782		

Thermal capacity for H2O/H2U (Full Oil) on request

3.6 Data tables – Type H3

Nominal power rating P_N (kW)

i_N	n1	n2	Gear unit size													
			712	713	714	715	716	717	718	719	720	721	722	723	724	725
20	1500	75			27		89		152		270		482		701	
	1000	50			18		60		101		180		321		467	
	750	38			13		45		76		135		241		351	
22.4	1500	67			23		80		138		250		437		609	
	1000	45			16		53		92		166		291		406	
	750	33			12		40		69		125		218		305	
25	1500	60			20	34	74	95	131	149	216	270	383	473	553	707
	1000	40			14	23	49	63	87	99	144	180	256	315	368	471
	750	30			10	17	37	48	65	75	108	135	192	236	276	353
28	1500	54			19	32	63	85	116	135	195	250	353	428	483	614
	1000	36			13	21	42	57	78	90	130	166	235	286	322	409
	750	27			9.4	16	32	42	58	68	97	125	176	214	242	307
31.5	1500	48			17	28	57	78	110	125	170	216	318	376	462	557
	1000	32			12	19	38	52	73	83	113	144	212	251	308	371
	750	24			8.7	14	28	39	55	62	85	108	159	188	231	278
35.5	1500	42			15	26	53	67	100	105	157	195	288	346	402	487
	1000	28			10	17	35	45	66	70	105	130	192	231	268	325
	750	21			7.6	13	26	34	50	52	79	97	144	173	201	243
40	1500	38			13	24	46	60	87	109	140	170	253	312	364	466
	1000	25			8.8	16	31	40	58	72	94	113	169	208	243	310
	750	19			6.6	12	23	30	44	54	70	85	127	156	182	233
45	1500	33			12	21	43	56	78	99	130	157	233	283	318	405
	1000	22			8.1	14	29	37	52	66	87	105	155	189	212	270
	750	17			6.1	10	21	28	39	49	65	79	117	141	159	202
50	1500	30			11	18	36	49	68	86	111	140	198	248	290	367
	1000	20			7.3	12	24	33	45	58	74	94	132	166	194	245
	750	15			5.5	9.1	18	25	34	43	55	70	99	124	145	184
56	1500	27			10	17	32	46	61	73	98	130	179	229	252	321
	1000	18			6.4	11	21	30	41	49	65	87	120	152	168	214
	750	13			4.8	8.4	16	23	31	36	49	65	90	114	126	160
63	1500	24			8.3	15	30	38	54	67	90	111	158	194	229	293
	1000	16			5.6	10	20	25	36	45	60	74	105	129	153	195
	750	12			4.2	7.5	15	19	27	33	45	55	79	97	114	146
71	1500	21			7.6	13	26	34	48	61	78	98	145	176	200	254
	1000	14			5.1	8.7	17	23	32	40	52	65	97	117	133	169
	750	11			3.8	6.5	13	17	24	30	39	49	73	88	100	127
80	1500	19				11		32		53		90		155		231
	1000	13				7.6		21		35		60		103		154
	750	9				5.7		16		27		45		77		115
90	1500	17				10		28		46		78		142		202
	1000	11				7.0		18		31		52		95		134
	750	8				5.2		14		23		39		71		101

3.6 Data tables – Type H3

Nominal output torque of low speed shaft (kNm)

Type	i _N	Gear unit size													
		712	713	714	715	716	717	718	719	720	721	722	723	724	725
H1	1.25	0.8	1.37	3.1	6.1	9.7		19.5		24		41			
	1.4	0.8	1.4	3.5	6.1	10		19.5		26		41			
	1.6	0.8	1.4	3.5	6.1	10		19.5		28		50		68	
	1.8	0.8	1.4	3.5	7.2	10		19.5		30		50		71	77
	2	0.8	1.4	3.5	7.2	10		19.5		33		50		76	90
	2.24	0.8	1.4	3.5	7.2	11		19.5		33		50		76	90
	2.5	0.8	1.4	3.5	7.2	11		19.5		33		50		78	92
	2.8	0.8	1.4	3.5	7.2	11		19.5		33		50		78	92
	3.15	0.8	1.27	3.5	7.1	11		20		33		50		77	92
	3.55	0.8	1.29	3.5	6.9	11		21		33		50		77	92
	4	0.8	1.3	3.5	7.2	11		21		33		50		77	92
	4.5	0.8	1.25	3.3	6.6	9		17.4		26		46		62	88
	5	0.6	1.15	3	6.1	9		16		23.5		39		59	83
	5.6	0.7	1.14	2.28	6.1	9		15.8		20.1		37		56	79
H2	6.3			3.3		11.4		20.4		34		60.8		86.4	
	7.1			3.3		11.4		20.4		34		60.8		86.4	
	8			3.3	6.8	11.4	14.4	20.4	25.9	34	43.0	60.8	76.0	86.4	110
	9			3.3	6.8	11.4	14.4	20.4	25.9	34	43.5	60.8	76.0	86.4	110
	10			3.3	6.8	11.4	14.4	20.4	25.9	34	43.5	60.8	76.0	86.4	110
	11.2			3.3	6.8	11.4	14.4	20.4	25.9	34	43.5	60.8	76.0	86.4	110
	12.5			3.3	6.8	11.4	14.4	20.4	25.9	34	43.5	60.8	76.0	86.4	110
	14			3.3	6.8	11.4	14.4	20.4	25.9	34	43.5	60.8	76.0	86.4	110
	16			3.3	6.8	11.4	14.4	20.4	25.9	34	43.5	60.8	76.0	86.4	110
	18			3.3	6.8	11.1	14.4	20.4	25.9	34	43.5	60.8	76.0	86.4	110
	20			3.4	6.8	11.6	14.4	20	25.9	35.7	43.5	63.6	76.0	90	110
	22.4			3.4	6.8	11.6	14	20	25.9	35.7	43.5	63.6	76.0	90	110
H3	25			3.4	5.5	11.6	15.5	21.7	25	35.7	44.1	63.6	78	90	114
	28			3.4	5.9	11.6	15.5	21.7	25	35.7	44.1	63.6	78	90	114
	31.5			3.4	6	11.6	15.3	21.7	26.3	35.7	44.1	63.6	78	90	114
	35.5			3.4	6	11.6	15.5	21.7	24.8	35.7	44.1	63.6	78	90	114
	40			3.4	6	11.6	15.5	21.7	27.3	35.7	44.1	63.6	78	90	114
	45			3.4	6	11.6	15.5	21.7	27.3	35.7	44.1	63.6	78	90	114
	50			3.4	6	11.6	15.5	21.7	27.3	35.7	44.1	63.6	78	90	114
	56			3.4	6	11.6	15.5	21.7	25.9	35.7	44.1	63.6	78	90	114
	63			3.4	6	11.6	15.5	21.7	27.3	35.7	44.1	63.6	78	90	114
	71			3.4	6	11.6	15.5	21.7	27.3	35.7	44.1	63.6	78	90	114
	80				6	11.6	15.5	21.7	27.3	35.9	44.1	63.6	78	91	114
90				6	11.6	15.5	21.7	26.5	35.9	44.1	63.6	78	91	114	
H4	100					11.6	15.5	21.7	25.5	35.9	44.4	63.6	78	91	115
	112					11.6	15.5	21.7	27.3	35.9	44.4	63.6	78	91	115
	125					11.6	15.5	21.7	27.3	35.9	44.4	63.6	78	91	115
	140					11.6	15.5	21.7	26.3	35.9	44.4	63.6	78	91	115
	160					11.6	15.5	21.7	27.3	35.9	44.4	63.6	78	91	115
	180					11.6	15.5	21.7	27.3	35.9	44.4	63.6	78	91	115
	200					11.6	15.5	21.7	27.3	35.9	44.4	63.6	78	91	115
	224					11.6	15.5	21.7	27.3	35.9	44.4	63.6	78	91	115
	250					11.6	15.5	21.7	27.3	35.9	44.4	63.6	78	91	115
	280					11.6	15.5	21.7	27.3	35.9	44.4	63.6	78	91	115
	315					11.6	15.5	21.7	27.3	35.9	44.4	63.6	78	91	115
	355					11.6	15.5	21.7	25.2	35.9	44.4	63.6	78	91	115
	400						15.5		27.3		44.4		78		115
450						15.5		25.4		44.4		78		115	

3.6 Data tables – Type H3

Thermal capacity (kW), n1 = 750 RPM

i _N		Gear unit size													
		712	713	714	715	716	717	718	719	720	721	722	723	724	725
20	P _{T1}			22		59		104		174		301		271	
	P _{T2}			37		74		143		191		324		370	
	P _{T3}					129		185		372		482		452	
	P _{T4}					144		223		389		506		551	
22.4	P _{T1}			22		56		99		171		313		252	
	P _{T2}			37		70		136		187		338		345	
	P _{T3}					122		176		366		503		421	
	P _{T4}					136		212		382		527		513	
25	P _{T1}			24	38	54	85	93	134	162	231	297	247	278	330
	P _{T2}			41	55	67	101	127	152	177	133	320	337	379	450
	P _{T3}					117	158	164	216	345	431	476	431	464	512
	P _{T4}					131	174	198	234	360	333	499	522	565	633
28	P _{T1}			23	38	53	80	89	127	153	227	295	257	261	308
	P _{T2}			38	55	66	96	121	145	167	130	318	351	356	420
	P _{T3}					115	149	157	205	326	424	472	449	436	478
	P _{T4}					128	165	190	223	340	328	495	543	531	590
31.5	P _{T1}			23	41	58	77	85	119	140	214	274	243	260	338
	P _{T2}			30	47	58	74	93	109	122	98	236	265	285	370
	P _{T3}					127	143	151	192	299	400	439	425	435	525
	P _{T4}					127	140	159	182	281	284	401	448	459	557
35.5	P _{T1}			21	38	54	75	86	113	144	202	268	241	246	318
	P _{T2}			29	44	55	72	94	103	126	93	232	264	269	347
	P _{T3}					118	140	152	182	307	378	430	422	411	494
	P _{T4}					118	137	160	171	289	269	394	445	434	523
40	P _{T1}			21	38	54	83	91	110	137	185	250	224	237	317
	P _{T2}			28	44	54	79	99	100	120	85	216	245	259	347
	P _{T3}					118	154	160	177	293	347	402	392	396	493
	P _{T4}					118	150	169	167	276	247	367	413	418	522
45	P _{T1}			20	36	52	77	91	110	134	190	246	220	219	300
	P _{T2}			27	41	52	74	100	101	117	88	212	241	240	328
	P _{T3}					113	143	161	178	286	356	394	385	366	466
	P _{T4}					113	140	170	168	270	253	361	406	386	494
50	P _{T1}			20	35	48	77	88	116	152	181	236	205	229	289
	P _{T2}			25	38	45	69	90	99	124	78	191	210	235	296
	P _{T3}					105	143	156	188	324	339	379	359	382	449
	P _{T4}					102	135	158	171	297	236	334	364	388	456
56	P _{T1}			19	30	44	67	76	106	126	160	240	182	193	241
	P _{T2}			26	36	46	66	87	100	114	77	215	207	219	274
	P _{T3}					102	130	141	177	284	314	401	333	336	389
	P _{T4}					104	130	152	172	273	231	376	358	363	422
63	P _{T1}			19	30	43	62	69	102	123	181	235	174	204	251
	P _{T2}			26	36	44	62	79	97	112	87	211	198	233	286
	P _{T3}					98	121	129	171	279	355	393	319	357	406
	P _{T4}					100	120	138	166	268	261	369	343	385	441
71	P _{T1}			18	31	40	63	71	98	115	166	226	197	210	235
	P _{T2}			25	38	41	63	80	93	105	80	203	224	239	268
	P _{T3}					91	123	131	165	260	327	378	361	366	380
	P _{T4}					93	123	141	160	250	241	355	388	395	412
80	P _{T1}				31		60		90		163		193		249
	P _{T2}				38		60		85		78		220		283
	P _{T3}						118		150		321		354		402
	P _{T4}						117		146		236		380		436
90	P _{T1}				30		56		91		153		185		256
	P _{T2}				36		56		86		73		210		291
	P _{T3}						109		152		300		339		413
	P _{T4}						109		148		221		364		448

Thermal capacity for H3V+ Expansion tank on request
Thermal capacity for H3O/H3U (Full Oil) on request

3.6 Data tables – Type H3

Thermal capacity (kW), n1 = 1000 RPM

i _N		Gear unit size													
		712	713	714	715	716	717	718	719	720	721	722	723	724	725
20	P _{T1}			27		71		121		192		273		266	
	P _{T2}			59		117		190		272		408		483	
	P _{T3}					141		201		390		455		448	
	P _{T4}					187		270		470		590		664	
22.4	P _{T1}			27		67		115		189		285		248	
	P _{T2}			58		111		181		267		425		450	
	P _{T3}					133		191		383		474		417	
	P _{T4}					177		257		462		615		619	
25	P _{T1}			30	44	64	88	107	143	178	221	270	240	274	325
	P _{T2}			64	86	106	145	169	234	252	332	403	445	496	572
	P _{T3}					128	160	179	225	361	421	449	425	460	507
	P _{T4}					170	218	240	316	435	532	582	630	682	754
28	P _{T1}			28	44	63	83	103	136	168	217	268	250	257	303
	P _{T2}			60	86	104	137	162	222	238	326	400	464	466	534
	P _{T3}					125	152	171	214	341	414	446	443	432	473
	P _{T4}					166	206	230	300	411	523	578	656	640	704
31.5	P _{T1}			28	47	70	80	99	128	154	204	249	237	256	333
	P _{T2}			48	74	92	105	124	167	175	246	297	351	372	470
	P _{T3}					138	146	164	201	313	390	414	419	431	520
	P _{T4}					161	171	190	239	333	432	462	533	546	657
35.5	P _{T1}			26	44	65	78	100	121	158	193	244	235	242	313
	P _{T2}			45	69	86	103	125	157	179	232	292	349	351	441
	P _{T3}					129	143	166	190	322	369	406	416	407	489
	P _{T4}					150	168	192	226	342	408	454	530	516	617
40	P _{T1}			26	44	65	86	105	118	151	177	228	218	233	313
	P _{T2}			44	69	86	113	132	153	171	213	272	324	338	441
	P _{T3}					128	157	175	185	307	339	379	386	392	488
	P _{T4}					149	184	202	220	327	375	423	492	497	616
45	P _{T1}			24	41	62	80	106	118	148	182	224	214	216	295
	P _{T2}			42	65	82	105	133	154	167	219	267	318	313	416
	P _{T3}					123	146	176	186	300	348	372	380	363	461
	P _{T4}					143	172	203	222	320	384	416	483	460	582
50	P _{T1}			25	41	58	80	102	125	167	174	215	200	225	285
	P _{T2}			40	60	72	99	120	152	177	196	241	278	306	376
	P _{T3}					114	146	169	196	339	332	358	354	379	445
	P _{T4}					128	165	188	224	350	354	384	432	460	536
56	P _{T1}			26	38	59	77	98	126	154	170	242	197	211	264
	P _{T2}			41	57	73	95	116	153	163	191	271	273	287	348
	P _{T3}					117	140	163	197	312	324	403	348	354	412
	P _{T4}					131	158	181	225	321	346	432	425	430	497
63	P _{T1}			25	38	56	71	89	121	151	192	238	188	224	275
	P _{T2}			41	57	70	88	105	148	160	216	266	262	304	363
	P _{T3}					112	130	149	191	306	367	395	334	376	430
	P _{T4}					125	147	165	218	316	391	424	407	456	518
71	P _{T1}			25	40	52	72	91	117	141	177	229	213	229	257
	P _{T2}			40	59	65	90	107	143	150	199	256	296	312	340
	P _{T3}					104	132	151	183	286	338	380	377	385	402
	P _{T4}					117	149	168	209	295	360	408	460	468	484
80	P _{T1}				40		69		107		174		209		272
	P _{T2}				59		86		130		196		290		360
	P _{T3}						127		167		332		369		425
	P _{T4}						143		191		354		451		512
90	P _{T1}				39		64		108		162		200		280
	P _{T2}				57		80		132		183		278		369
	P _{T3}						118		170		310		354		437
	P _{T4}						133		194		330		432		527

Thermal capacity for H3V+ Expansion tank on request
 Thermal capacity for H3O/H3U (Full Oil) on request

3.6 Data tables – Type H3

Thermal capacity (kW), n1 = 1500 RPM

i _N		Gear unit size													
		712	713	714	715	716	717	718	719	720	721	722	723	724	725
20	P _{T1}			27		69		118		188		271		264	
	P _{T2}			51		102		197		288		490		558	
	P _{T3}					139		199		386		452		445	
	P _{T4}					172		278		486		671		740	
22.4	P _{T1}			27		66		113		185		282		246	
	P _{T2}			51		97		188		283		511		521	
	P _{T3}					132		189		380		471		415	
	P _{T4}					163		264		478		700		690	
25	P _{T1}			29	43	63	86	105	141	175	216	267	238	271	321
	P _{T2}			56	75	93	146	175	230	267	334	483	515	573	662
	P _{T3}					126	159	176	223	358	417	446	423	457	504
	P _{T4}					156	219	247	312	450	535	662	700	759	844
28	P _{T1}			27	43	62	81	101	134	165	213	265	248	254	300
	P _{T2}			52	75	91	138	168	219	252	328	480	536	539	617
	P _{T3}					124	150	169	212	338	410	443	440	429	470
	P _{T4}					153	207	236	297	425	526	658	729	713	788
31.5	P _{T1}			27	46	68	78	97	125	151	200	246	234	254	330
	P _{T2}			52	81	100	133	161	205	231	310	446	507	538	679
	P _{T3}					137	144	162	198	310	386	411	416	428	517
	P _{T4}					169	199	227	278	390	496	611	689	712	866
35.5	P _{T1}			26	43	64	76	98	118	155	189	242	233	240	310
	P _{T2}			49	76	94	130	163	194	237	293	437	504	508	638
	P _{T3}					128	141	164	187	319	365	404	414	405	486
	P _{T4}					157	194	229	263	401	468	599	685	673	814
40	P _{T1}			25	43	63	84	103	115	148	174	225	216	231	309
	P _{T2}			48	75	93	143	172	189	227	269	408	468	489	637
	P _{T3}					127	155	173	182	304	335	377	384	390	485
	P _{T4}					157	214	241	256	382	430	559	636	648	812
45	P _{T1}			24	40	61	78	104	116	145	178	221	212	214	292
	P _{T2}			46	71	90	133	173	190	222	276	401	460	453	602
	P _{T3}					122	144	174	184	297	344	370	377	361	458
	P _{T4}					151	199	243	258	374	441	549	625	599	768
50	P _{T1}			24	40	57	78	100	122	164	170	213	198	223	282
	P _{T2}			46	70	83	133	167	200	251	263	385	429	473	580
	P _{T3}					113	144	167	193	336	328	356	352	377	442
	P _{T4}					140	199	234	271	423	421	528	583	626	740
56	P _{T1}			25	38	58	75	96	123	151	167	240	195	209	261
	P _{T2}			48	66	85	127	160	202	230	257	434	421	442	537
	P _{T3}					116	138	161	195	309	321	401	346	352	409
	P _{T4}					143	191	225	273	389	412	595	573	585	685
63	P _{T1}			25	38	55	69	88	119	148	188	235	187	222	272
	P _{T2}			47	66	81	118	146	195	226	291	426	404	469	560
	P _{T3}					111	128	147	188	304	363	393	332	374	427
	P _{T4}					137	177	205	264	382	466	584	549	621	715
71	P _{T1}			24	39	51	71	89	114	138	173	226	211	227	255
	P _{T2}			46	69	76	120	149	187	211	268	410	456	481	524
	P _{T3}					103	131	149	181	283	334	378	375	383	399
	P _{T4}					127	180	209	254	357	429	561	620	637	669
80	P _{T1}				39		68		104		170		207		269
	P _{T2}				69		115		171		263		448		554
	P _{T3}						125		165		328		367		422
	P _{T4}						173		232		421		608		707
90	P _{T1}				38		63		106		159		198		277
	P _{T2}				67		107		173		246		429		570
	P _{T3}						116		168		307		352		434
	P _{T4}						160		235		393		583		727

Thermal capacity for H3V+ Expansion tank on request
Thermal capacity for H3O/H3U (Full Oil) on request

3.7 Data tables – Type H4

Nominal power rating P_N (kW)

i _N	n1	n2	Gear unit size													
			712	713	714	715	716	717	718	719	720	721	722	723	724	725
80	1500	19					23		42		69		122		178	
	1000	13					15		28		46		81		119	
	750	9					12		21		35		61		89	
90	1500	17					21		38		64		110		155	
	1000	11					14		25		43		74		103	
	750	8					10		19		32		55		77	
100	1500	15					19	25	33	39	55	69	97	120	141	179
	1000	10					13	16	22	26	37	46	65	80	94	120
	750	8					10	12	17	19	28	35	49	60	70	90
112	1500	13					16	22	30	38	51	64	89	108	123	156
	1000	9					11	15	20	25	34	43	60	72	82	104
	750	7					8.2	11	15	19	26	32	45	54	61	78
125	1500	12					15	20	27	33	44	55	75	95	112	141
	1000	8					10	14	18	22	30	37	50	63	75	94
	750	6					7.3	10	14	17	22	28	37	48	56	71
140	1500	11					14	17	25	28	40	52	68	88	97	124
	1000	7					9.0	12	17	19	27	34	45	58	65	82
	750	5					6.8	8.7	12	14	20	26	34	44	49	62
160	1500	9					11	15	22	27	37	45	60	74	88	113
	1000	6					7.5	10	14	18	25	30	40	49	59	75
	750	5					5.6	7.7	11	14	19	22	30	37	44	56
180	1500	8					10	14	19	25	32	40	55	67	77	98
	1000	6					6.7	10	13	16	21	27	37	44	52	65
	750	4					5.0	7.2	10	12	16	20	27	33	39	49
200	1500	8					9.3	12	18	21	28	37	49	58	73	89
	1000	5					6.2	8.0	12	14	19	25	33	39	48	59
	750	4					4.7	6.0	8.8	11	14	19	25	29	36	44
224	1500	7					7.9	11	15	19	26	32	45	54	63	78
	1000	4					5.3	7.1	10	13	17	21	30	36	42	52
	750	3					3.9	5.3	7.7	10	13	16	22	27	32	39
250	1500	6					7.1	10	14	17	22	28	39	48	57	73
	1000	4					4.7	6.6	9.1	12	15	19	26	32	38	49
	750	3					3.5	5.0	6.8	8.7	11	14	20	24	29	36
280	1500	5					6.6	8.4	12	15	20	26	36	44	50	63
	1000	4					4.4	5.6	8.2	10	13	17	24	29	33	42
	750	3					3.3	4.2	6.1	7.6	10	13	18	22	25	32
315	1500	5					5.5	7.5	11	14	18	22	30	38	45	57
	1000	3					3.7	5.0	7.5	9.0	12	15	20	26	30	38
	750	2					2.8	3.7	5.6	6.8	8.8	11	15	19	23	29
355	1500	4					5.1	7.0	10	11	16	20	27	35	40	50
	1000	3					3.4	4.6	6.7	7.5	11	13	18	24	26	33
	750	2					2.6	3.5	5.0	5.6	8	10	14	18	20	25
400	1500	4						5.9		11		18		29		46
	1000	3						3.9		7.4		12		19		30
	750	2						2.9		5.6		9		15		23
450	1500	3						5.4		9.3		16		27		40
	1000	2						3.6		6.2		11		18		27
	750	2						2.7		4.6		8		13		20

3.7 Data tables – Type H4

Nominal output torque of low speed shaft (kNm)

Type	i _n	Gear unit size														
		712	713	714	715	716	717	718	719	720	721	722	723	724	725	
H1	1.25	0.8	1.37	3.1	6.1	9.7		19.5		24		41				
	1.4	0.8	1.4	3.5	6.1	10		19.5		26		41				
	1.6	0.8	1.4	3.5	6.1	10		19.5		28		50		68		
	1.8	0.8	1.4	3.5	7.2	10		19.5		30		50		71	77	
	2	0.8	1.4	3.5	7.2	10		19.5		33		50		76	90	
	2.24	0.8	1.4	3.5	7.2	11		19.5		33		50		76	90	
	2.5	0.8	1.4	3.5	7.2	11		19.5		33		50		78	92	
	2.8	0.8	1.4	3.5	7.2	11		19.5		33		50		78	92	
	3.15	0.8	1.27	3.5	7.1	11		20		33		50		77	92	
	3.55	0.8	1.29	3.5	6.9	11		21		33		50		77	92	
	4	0.8	1.3	3.5	7.2	11		21		33		50		77	92	
	4.5	0.8	1.25	3.3	6.6	9		17.4		26		46		62	88	
	5	0.6	1.15	3	6.1	9		16		23.5		39		59	83	
	5.6	0.7	1.14	2.28	6.1	9		15.8		20.1		37		56	79	
H2	6.3			3.3		11.4		20.4		34		60.8		86.4		
	7.1			3.3		11.4		20.4		34		60.8		86.4		
	8			3.3	6.8	11.4	14.4	20.4	25.9	34	43.0	60.8	76.0	86.4	110	
	9			3.3	6.8	11.4	14.4	20.4	25.9	34	43.5	60.8	76.0	86.4	110	
	10			3.3	6.8	11.4	14.4	20.4	25.9	34	43.5	60.8	76.0	86.4	110	
	11.2			3.3	6.8	11.4	14.4	20.4	25.9	34	43.5	60.8	76.0	86.4	110	
	12.5			3.3	6.8	11.4	14.4	20.4	25.9	34	43.5	60.8	76.0	86.4	110	
	14			3.3	6.8	11.4	14.4	20.4	25.9	34	43.5	60.8	76.0	86.4	110	
	16			3.3	6.8	11.4	14.4	20.4	25.9	34	43.5	60.8	76.0	86.4	110	
	18			3.3	6.8	11.1	14.4	20.4	25.9	34	43.5	60.8	76.0	86.4	110	
	20			3.4	6.8	11.6	14.4	20	25.9	35.7	43.5	63.6	76.0	90	110	
	22.4			3.4	6.8	11.6	14	20	25.9	35.7	43.5	63.6	76.0	90	110	
H3	25			3.4	5.5	11.6	15.5	21.7	25	35.7	44.1	63.6	78	90	114	
	28			3.4	5.9	11.6	15.5	21.7	25	35.7	44.1	63.6	78	90	114	
	31.5			3.4	6	11.6	15.3	21.7	26.3	35.7	44.1	63.6	78	90	114	
	35.5			3.4	6	11.6	15.5	21.7	24.8	35.7	44.1	63.6	78	90	114	
	40			3.4	6	11.6	15.5	21.7	27.3	35.7	44.1	63.6	78	90	114	
	45			3.4	6	11.6	15.5	21.7	27.3	35.7	44.1	63.6	78	90	114	
	50			3.4	6	11.6	15.5	21.7	27.3	35.7	44.1	63.6	78	90	114	
	56			3.4	6	11.6	15.5	21.7	25.9	35.7	44.1	63.6	78	90	114	
	63			3.4	6	11.6	15.5	21.7	27.3	35.7	44.1	63.6	78	90	114	
	71			3.4	6	11.6	15.5	21.7	27.3	35.7	44.1	63.6	78	90	114	
	80				6	11.6	15.5	21.7	27.3	35.9	44.1	63.6	78	91	114	
90				6	11.6	15.5	21.7	26.5	35.9	44.1	63.6	78	91	114		
H4	100					11.6	15.5	21.7	25.5	35.9	44.4	63.6	78	91	115	
	112					11.6	15.5	21.7	27.3	35.9	44.4	63.6	78	91	115	
	125					11.6	15.5	21.7	27.3	35.9	44.4	63.6	78	91	115	
	140					11.6	15.5	21.7	26.3	35.9	44.4	63.6	78	91	115	
	160					11.6	15.5	21.7	27.3	35.9	44.4	63.6	78	91	115	
	180					11.6	15.5	21.7	27.3	35.9	44.4	63.6	78	91	115	
	200					11.6	15.5	21.7	27.3	35.9	44.4	63.6	78	91	115	
	224					11.6	15.5	21.7	27.3	35.9	44.4	63.6	78	91	115	
	250					11.6	15.5	21.7	27.3	35.9	44.4	63.6	78	91	115	
	280					11.6	15.5	21.7	27.3	35.9	44.4	63.6	78	91	115	
	315					11.6	15.5	21.7	27.3	35.9	44.4	63.6	78	91	115	
	355					11.6	15.5	21.7	25.2	35.9	44.4	63.6	78	91	115	
	400							15.5		27.3		44.4		78		115
	450							15.5		25.4		44.4		78		115

3.7 Data tables – Type H4

Thermal capacity (kW), $n_1 = 750$ RPM

i_N		Gear unit size													
		712	713	714	715	716	717	718	719	720	721	722	723	724	725
80	P _{T1}					24		45		76		143		172	
90	P _{T1}					24		41		72		140		164	
100	P _{T1}					24	35	44	59	70	87	132	131	159	193
112	P _{T1}					24	34	40	53	67	79	127	123	150	175
125	P _{T1}					22	33	42	56	67	77	121	116	144	171
140	P _{T1}					21	34	41	53	66	77	124	116	137	168
160	P _{T1}					20	32	38	56	71	76	118	111	144	161
180	P _{T1}					20	30	38	54	65	76	116	113	140	154
200	P _{T1}					19	29	36	50	62	81	118	108	141	161
224	P _{T1}					21	29	33	51	64	74	117	106	131	156
250	P _{T1}					20	27	35	48	60	71	116	108	131	157
280	P _{T1}					20	30	34	44	60	73	115	107	127	147
315	P _{T1}					19	29	36	46	59	69	105	106	119	147
355	P _{T1}					19	29	35	44	62	69	105	106	115	142
400	P _{T1}						28		48		68		97		133
450	P _{T1}						28		46		71		97		128

Thermal capacity (kW), $n_1 = 1000$ RPM

i_N		Gear unit size													
		712	713	714	715	716	717	718	719	720	721	722	723	724	725
80	P _{T1}					25		46		75		142		193	
90	P _{T1}					25		42		71		139		184	
100	P _{T1}					24	27	45	48	69	86	131	147	179	201
112	P _{T1}					24	26	41	43	66	78	126	138	168	183
125	P _{T1}					22	25	43	45	66	76	121	130	162	178
140	P _{T1}					21	26	42	44	66	76	124	130	154	175
160	P _{T1}					21	24	38	46	70	75	117	124	162	168
180	P _{T1}					20	23	39	44	64	75	116	127	157	161
200	P _{T1}					19	22	37	41	61	81	118	121	158	168
224	P _{T1}					21	22	34	41	63	74	117	119	147	163
250	P _{T1}					21	21	36	39	59	70	115	122	147	164
280	P _{T1}					20	23	35	36	60	72	115	121	142	153
315	P _{T1}					20	22	37	38	59	68	104	119	133	153
355	P _{T1}					20	22	36	36	61	68	105	119	129	148
400	P _{T1}						21		40		67		109		139
450	P _{T1}						21		38		70		109		134

Thermal capacity (kW), $n_1 = 1500$ RPM

i_N		Gear unit size													
		712	713	714	715	716	717	718	719	720	721	722	723	724	725
80	P _{T1}					23		43		70		135		183	
90	P _{T1}					23		40		66		132		174	
100	P _{T1}					23	25	42	45	65	80	124	139	169	191
112	P _{T1}					24	25	40	42	65	76	125	137	167	181
125	P _{T1}					22	24	42	44	64	75	119	128	160	176
140	P _{T1}					21	26	41	43	64	74	122	129	153	173
160	P _{T1}					20	24	38	45	69	74	116	123	160	167
180	P _{T1}					20	23	38	43	63	74	115	126	155	159
200	P _{T1}					19	22	36	40	60	79	116	120	156	167
224	P _{T1}					21	21	33	41	62	72	115	118	146	161
250	P _{T1}					20	20	35	38	58	69	114	120	146	163
280	P _{T1}					20	23	34	35	58	70	113	119	141	152
315	P _{T1}					19	22	36	37	57	67	103	118	132	152
355	P _{T1}					19	21	35	36	60	67	104	117	127	147
400	P _{T1}						21		39		66		108		138
450	P _{T1}						21		37		69		108		133

Thermal capacity for H4V+ Expansion tank on request
 Thermal capacity for H4O/H4U (Full Oil) on request

3.8 Data tables – Type B2

Nominal power rating P_N (kW)

i_N	n1	n2	Gear unit size													
			712	713	714	715	716	717	718	719	720	721	722	723	724	725
5	1500	300	26		97		294		591		959		1515 *		2292 *	
	1000	200	17		64		196		394		640		1010		1528	
	750	150	13		48		147		296		480		757		1146	
5.6	1500	268	22	39	86		272	329	536	637	833	1013	1343 *		1997 *	
	1000	179	15	26	57		181	219	357	425	556	676	895		1331	
	750	134	11	19	43		136	164	268	318	417	507	671		999	
6.3	1500	238	20	34	77	155	235	304	470	588	756	971	1293 *	1584 *	1888 *	2238 *
	1000	159	14	23	51	104	157	203	314	392	504	648	862	1070	1258	1492
	750	119	10	17	38	78	117	152	235	294	378	486	646	803	944	1119
7.1	1500	211	18	31	67	138	205	264	429	518	661	894	1211 *	1458 *	1778	2066 *
	1000	141	12	21	45	92	136	176	286	345	441	596	807	972	1186	1378
	750	106	8.9	16	34	69	102	132	214	259	331	447	605	729	889	1033
8	1500	188	15	27	60	124	189	240	373	472	580	779	1048	1316 *	1609	1998 *
	1000	125	10	18	40	83	126	160	249	315	387	519	698	877	1073	1332
	750	94	7.7	14	30	62	95	120	187	236	290	389	524	658	805	999
9	1500	167	14	24	53	108	164	212	328	410	527	703	943	1161	1441	1722
	1000	111	9.4	16	36	72	109	141	218	273	351	469	629	774	960	1148
	750	83	7.1	12	27	54	82	106	164	205	263	352	472	580	720	861
10	1500	150	13	22	48	96	147	184	302	361	460	610	877	1072	1334	1617
	1000	100	8.5	14	32	64	98	123	201	241	307	406	585	715	889	1078
	750	75	6.4	11	24	48	73	92	151	180	230	305	439	536	667	808
11.2	1500	134	11	19	43	86	136	167	268	329	417	534	780	942	1213	1442
	1000	89	7.4	13	29	57	91	111	179	219	278	356	520	628	808	961
	750	67	5.6	10	21	43	68	83	134	164	208	267	390	471	606	721
12.5	1500	120	10	17	37	78	111	152	235	294	378	505	702	842	957	1314
	1000	80	6.8	11	25	52	74	101	157	196	252	337	468	561	638	876
	750	60	5.1	8.5	19	39	56	76	118	147	189	252	351	421	478	657
14	1500	107		16	32	69	100	132	217	259	331	438	603	770	965	1172
	1000	71		10	21	46	67	88	144	173	220	292	402	513	650	822
	750	54		7.8	16	35	50	66	108	130	165	219	302	385	488	624
16	1500	94			30	60	90	120	187	226	290	383	460	658	824	1024
	1000	63			20	40	60	80	124	151	193	256	307	439	544	704
	750	47			15	30	45	60	93	113	145	192	230	329	412	536
18	1500	83			27	48	77	99	164	188	263	310	437	459	622	779
	1000	56			18	32	52	66	109	125	176	206	292	306	414	520
	750	42			13	24	39	49	82	94	132	155	219	230	311	390
20	1500	75				43	70	92	151	173	230	305	410	459		695
	1000	50				28	47	61	101	115	153	203	273	306		464
	750	38				21	35	46	75	86	115	152	205	230		348
22.4	1500	67				38		83		157		267		428		617
	1000	45				25		56		105		178		286		411
	750	33				19		42		79		134		214		308

* Required force lubrication

3.8 Data tables – Type B2

Nominal output torque of low speed shaft (kNm)

Type	i _N	Gear unit size													
		712	713	714	715	716	717	718	719	720	721	722	723	724	725
B2	5	0.8		3		9.5		19		30		48.2		70	
	5.6	0.8	1.4	3		9.5	12	19	24	30	35	48.2		70	
	6.3	0.8	1.4	3	6.2	9.5	12	19	24	30	38	52.5	62.8	74	86
	7.1	0.8	1.4	3	6.2	9.5	12	19	24	30	38.8	52.5	62.8	78	89
	8	0.8	1.4	3	6.2	9.5	12	19	24	30	38.6	54	64.5	81	97
	9	0.8	1.4	3	6.2	9.5	12	19	24	30	39.5	55	65.2	81.1	95
	10	0.8	1.4	3	6.2	9.5	12	19	24	30	38	54.6	66.3	81.5	100
	11.2	0.8	1.4	3	6.2	9.5	12	19	24	30	38	56	66.3	85	100.5
	12.5	0.8	1.4	2.9	6.2	9	12	19	24	30	39.5	57	65.9	75	101
	14		1.4	2.7	6.2	9	12	19	24	30	38	52.3	66.3	67.1	101
	16			3	6	9	12	19	23	30	38	47.4	64.5	70	80
	18			3	5.5	9	11.2	19	22	30	34.8	51	51.6	70	86
	20				5.5	9	12	19	23	30	38	51	56.8		86
22.4				5.5		12		23		38		60.3		86	
B3	12.5			3.4		9.5		17		30		53		79	
	14			3.4		10		19		32		58		81	
	16			3.4	6.6	11.9	12	20	21.5	32	39.5	61	67	84	99.4
	18			3.4	6.8	11.9	13.5	21.8	24	34	39.5	63.6	72	86	102
	20			3.4	6.8	11.9	13.5	21.8	27.5	36	39.5	63.6	77	91	105
	22.4			3.4	6.8	11.9	15.5	21.8	27.5	36	45	63.6	79	91	108
	25			3.4	6.8	11.9	16	21.8	27.5	36	47	63.6	79	91	113
	28			3.4	6.8	11.9	16	21.8	27.5	36	47	63.6	79	91	115
	32			3.4	6.8	11.9	16	21.8	27.5	36	47	63.6	79	91	115
	35.5			3.4	6.8	11.9	16	21.8	25.7	36	47	63.6	79	91	115
	40			3.4	6.8	11.9	16	21.8	27.5	36	47	63.6	79	91	115
	45			3.4	6.8	11.9	16	21.8	27.5	36	47	63.6	79	91	115
	50			3.4	6.8	11.9	16	21.8	26.5	36	47	63.6	79	91	115
	56			3.4	6.8	11.9	16	21.4	27.5	36	47	63.6	79	91	115
	63			3.4	6.8	11.9	16	21.8	27.5	36	47	63.6	79	91	115
	71			3.4	6.2	11.9	16	21.8	27.1	36	46	63.6	79	91	115
80				6.6	11.9	16	21.8	27.5	36	47	61.6	79	91	115	
90				6.7	11.9	16	21.8	26.8	36	47	63.6	79	91	115	
B4	100					11.9	16	21.8	27.5	36	45	63.6	79	91	115
	112					11.6	16	21.8	27.5	36	45	63.6	79	91	115
	125					11.9	16	21.8	27.5	36	48	63.6	79	91	115
	140					11.9	16	21.8	27.5	36	48	63.6	79	91	115
	140					11.6	16	21.8	27.5	36	45	63.6	80.5	91	115
	180					11.9	16	21.8	27.5	36	45	63.6	81.5	91	115
	200					11.9	15.7	21.8	27.5	36	45	63.6	81.5	91	115
	224					11.6	16	21.8	27.5	36	48	63.6	80.5	91	115
	250					11.9	16	21.8	27.5	36	48	63.6	79.6	91	115
	280					11.9	16	21.8	27.5	36	48	63.6	80.5	91	115
	315					11.6	16	21.8	27.5	36	48	63.6	80.5	91	115
	355					11.5	16	17.8	27.5	36	45	63.6	79	91	115
	400							14.7	27.5		45		79		115
	450							15.5		19.7		48		79	

3.8 Data tables – Type B2

Thermal capacity (kW), $n_1 = 1000$ RPM

i_N		Gear unit size													
		712	713	714	715	716	717	718	719	720	721	722	723	724	725
5	P _{T1}	12		35		77		130							
	P _{T2}	34		86		208		334		422		574		783	
	P _{T3}					238		279		532		627		686	
	P _{T4}					369		483		778		936		1119	
5.6	P _{T1}	12	20	34		76	96	132	151						
	P _{T2}	33	47	85		207	252	339	388	392	450	584		773	
	P _{T3}					236	261	283	303	494	535	637		678	
	P _{T4}					367	418	490	539	723	804	951		1105	
6.3	P _{T1}	12	19	33	44	71	95	123	156	162					
	P _{T2}	34	45	81	122	191	251	315	400	390	433	563	672	749	
	P _{T3}					218	260	263	312	491	516	614	644	657	
	P _{T4}					339	415	456	556	719	775	918	1030	1070	
7.1	P _{T1}	13	22	31	48	69	97	133	160	164	190	276	328		
	P _{T2}	33	47	69	119	169	232	310	373	358	431	543	699	707	
	P _{T3}					200	249	271	306	465	530	618	700	652	
	P _{T4}					300	384	448	518	659	770	885	1072	1010	
8	P _{T1}	13	22	32	48	73	101	127	166	162	185	275	329		
	P _{T2}	31	45	69	114	168	228	280	364	333	395	510	662	709	
	P _{T3}					203	251	251	308	442	497	596	681	675	
	P _{T4}					298	378	404	506	613	707	832	1014	1013	
9	P _{T1}	13	21	36	42	67	91	119	151	162	174	260	292	354	
	P _{T2}	30	43	76	99	156	205	261	332	333	372	483	588	677	
	P _{T3}					187	225	235	281	442	468	564	606	644	
	P _{T4}					276	339	378	462	614	666	787	902	967	
10	P _{T1}	11	20	31	41	58	84	118	141	149	171	250	306	311	
	P _{T2}	25	41	66	97	135	189	260	311	306	366	465	615	595	
	P _{T3}					163	208	233	263	407	461	543	633	566	
	P _{T4}					239	313	375	432	565	656	758	943	850	
11.2	P _{T1}	12	20	35	51	66	95	119	158	153	180	258	326	357	
	P _{T2}	24	35	65	106	134	187	229	304	276	337	419	575	598	
	P _{T3}					170	217	220	277	386	447	521	632	614	
	P _{T4}					238	309	330	423	509	603	683	881	855	
12.5	P _{T1}	12	19	33	45	66	83	111	142	154	166	244	275	330	
	P _{T2}	24	33	62	92	135	164	214	272	277	310	397	484	553	
	P _{T3}					171	190	206	248	388	410	495	532	567	
	P _{T4}					239	271	309	378	511	554	648	741	790	
14	P _{T1}	12	19	32	44	68	85	111	133	142	163	231	286	338	
	P _{T2}	25	33	59	90	139	167	213	255	256	306	375	503	566	
	P _{T3}					176	194	205	232	357	405	467	554	581	
	P _{T4}					246	276	308	354	471	547	611	771	808	
16	P _{T1}	12	16	29	42	65	88	126	130	129	151	250	265	344	
	P _{T2}	25	28	54	87	133	173	243	250	232	282	407	467	575	
	P _{T3}					168	201	234	227	324	373	506	513	590	
	P _{T4}					235	287	350	347	428	505	663	715	822	
18	P _{T1}	12	16	30	37	61	82	124	150	130	135	239	257	328	
	P _{T2}	25	28	55	77	124	162	240	288	234	252	389	453	548	
	P _{T3}					157	188	231	262	328	334	484	498	563	
	P _{T4}					220	268	346	400	432	452	634	694	783	
20	P _{T1}		15		35	59	78	125	146	134	138	230	281		
	P _{T2}		27		73	120	154	240	281	242	259	375	495	636	
	P _{T3}					153	178	231	256	338	342	467	544	558	
	P _{T4}					214	254	347	391	445	463	611	758	890	
22.4	P _{T1}				36		76		145		141		264		
	P _{T2}				75		151		279		264		466		
	P _{T3}						175		254		349		512		
	P _{T4}						249		388		472		713		

3.8 Data tables – Type B2

Thermal capacity (kW), $n_1 = 1500$ RPM

i_N		Gear unit size													
		712	713	714	715	716	717	718	719	720	721	722	723	724	725
5	P _{T1}	14		40											
	P _{T2}	38		100		236				503		651		934	
	P _{T3}					249		399		570		711		739	
	P _{T4}					397		547		859		1013		1270	
5.6	P _{T1}	14	23	39		87	110								
	P _{T2}	37	47	98		234	303	405	426	468	517	662		923	
	P _{T3}					247	275	302	325	529	637	722		730	
	P _{T4}					394	468	555	577	798	872	1029		1254	
6.3	P _{T1}	14	22	38	51	81	109								
	P _{T2}	39	45	94	152	216	301	376	438	465	498	638	703	894	910
	P _{T3}					228	273	281	334	526	614	697	687	707	670
	P _{T4}					364	465	517	594	794	840	993	1061	1215	1229
7.1	P _{T1}	14	23	32	50	71	101	138	166						
	P _{T2}	37	47	80	149	192	278	370	409	427	495	616	732	844	931
	P _{T3}					202	253	276	312	483	610	672	715	668	685
	P _{T4}					322	430	508	555	728	835	958	1104	1147	1258
8	P _{T1}	15	25	36	54	81	113	142	186	193	284	354			
	P _{T2}	36	44	79	142	191	274	334	399	397	454	579	693	846	915
	P _{T3}					211	263	266	328	473	595	676	723	722	723
	P _{T4}					321	423	458	541	678	766	900	1045	1150	1236
9	P _{T1}	14	24	40	47	75	102	133	170	193	267	335			
	P _{T2}	34	43	88	123	176	246	312	365	397	428	547	616	807	852
	P _{T3}					196	236	249	299	474	561	639	643	689	674
	P _{T4}					297	379	428	494	678	722	851	929	1097	1151
10	P _{T1}	12	23	35	46	65	94	132	158	177	263	323			
	P _{T2}	29	41	76	121	153	227	310	341	365	421	527	644	710	914
	P _{T3}					170	218	248	280	436	552	616	672	605	723
	P _{T4}					257	351	425	462	624	710	820	971	965	1235
11.2	P _{T1}	11	20	34	50	65	93	116	155	160	242	291			
	P _{T2}	27	35	74	132	152	224	273	333	329	388	475	601	714	830
	P _{T3}					169	215	218	274	392	508	555	628	609	656
	P _{T4}					256	347	374	452	562	654	739	907	970	1121
12.5	P _{T1}	13	21	37	49	73	92	122	156	180	250	310	305	366	
	P _{T2}	27	33	72	115	153	197	255	298	331	356	450	506	659	729
	P _{T3}					178	199	217	262	414	495	561	562	603	616
	P _{T4}					257	304	350	405	564	600	701	764	896	985
14	P _{T1}	13	21	35	48	75	93	122	146	166	247	293	317	375	
	P _{T2}	29	33	68	112	157	200	254	279	305	351	425	527	675	738
	P _{T3}					183	203	217	245	382	488	529	585	618	624
	P _{T4}					264	309	349	379	520	593	661	795	918	997
16	P _{T1}	14	17	32	46	72	97	139	143	151	228	317	294	381	323
	P _{T2}	29	28	62	108	150	208	289	274	277	324	461	488	686	652
	P _{T3}					175	210	247	241	347	450	574	542	628	552
	P _{T4}					253	321	397	371	472	547	717	737	933	881
18	P _{T1}	13	17	33	41	67	91	137	165	153	204	304	285	363	346
	P _{T2}	28	27	64	96	140	195	286	316	280	290	441	474	654	699
	P _{T3}					163	197	244	277	350	403	549	526	598	591
	P _{T4}					236	301	392	428	477	490	686	715	889	944
20	P _{T1}		17		39	65	86	137	162	157	209	293	312		357
	P _{T2}		26		91	137	184	286	309	288	297	425	518		721
	P _{T3}					159	186	244	271	361	413	529	575		610
	P _{T4}					230	285	393	418	492	501	661	781		975
22.4	P _{T1}				40		84		160		213		293		335
	P _{T2}				93		181		306		303		487		678
	P _{T3}						183		269		421		541		573
	P _{T4}						279		415		512		735		916

3.9 Data tables – Type B3

Nominal power rating P_N (kW)

i _N	n1	n2	Gear unit size													
			712	713	714	715	716	717	718	719	720	721	722	723	724	725
12.5	1500	120			44		120		225		369		659		1008	
	1000	80			29		80		150		246		439		672	
	750	60			22		60		113		185		329		504	
14	1500	107			38		113		220		364		652		918	
	1000	71			26		75		147		243		435		612	
	750	54			19		56		110		182		326		459	
16	1500	94			34	66	123	121	202	224	321	393	615	666	861	1009
	1000	63			23	44	82	80	134	149	214	262	410	444	574	673
	750	47			17	33	61	60	101	112	161	197	308	333	431	505
18	1500	83			31	60	105	121	198	219	299	364	561	636	786	920
	1000	56			21	40	70	81	132	146	199	243	374	424	524	613
	750	42			16	30	53	61	99	110	149	182	280	318	393	460
20	1500	75			27	53	93	111	180	218	278	321	508	622	733	856
	1000	50			18	35	62	74	120	145	186	214	339	414	489	571
	750	38			13	26	47	55	90	109	139	160	254	311	366	428
22.4	1500	67			24	48	83	109	157	196	257	320	446	557	655	785
	1000	45			16	32	56	73	105	131	172	213	297	371	437	523
	750	33			12	24	42	54	79	98	129	160	223	279	328	392
25	1500	60			22	42	77	100	140	178	222	294	411	505	573	714
	1000	40			14	28	52	67	93	119	148	196	274	337	382	476
	750	30			11	21	39	50	70	89	111	147	205	252	286	357
28	1500	54			19	37	65	89	125	156	194	272	354	443	510	659
	1000	36			13	24	43	59	84	104	129	181	236	296	340	439
	750	27			9.4	18	33	45	63	78	97	136	177	222	255	329
31.5	1500	48			16	34	58	83	110	139	179	235	311	408	456	576
	1000	32			11	22	39	55	73	93	119	157	207	272	304	384
	750	24			8.2	17	29	41	55	69	90	118	155	204	228	288
35.5	1500	42			15	29	54	69	98	116	155	205	286	352	399	506
	1000	28			10	19	36	46	65	78	103	137	191	234	266	337
	750	21			7.5	15	27	35	49	58	77	102	143	176	199	253
40	1500	38			13	26	47	62	87	109	139	189	254	309	366	459
	1000	25			9.0	17	31	41	58	73	93	126	169	206	244	306
	750	19			6.7	13	23	31	44	54	70	95	127	154	183	229
45	1500	33			12	23	42	58	79	97	129	164	223	284	328	401
	1000	22			7.9	16	28	38	52	65	86	109	149	189	218	267
	750	17			5.9	12	21	29	39	48	64	82	112	142	164	201
50	1500	30			11	21	39	50	70	84	111	147	205	252	286	363
	1000	20			7.2	14	26	33	47	56	74	98	137	168	191	242
	750	15			5.4	10	19	25	35	42	56	74	103	126	143	182
56	1500	27			9.4	18	33	45	61	78	97	136	177	222	255	329
	1000	18			6.3	12	22	30	41	52	65	91	118	148	170	220
	750	13			4.7	9.2	16	22	31	39	48	68	88	111	128	165
63	1500	24			8.2	17	29	41	55	69	90	118	155	204	228	288
	1000	16			5.5	11	19	28	37	46	60	78	104	136	152	192
	750	12			4.1	8.4	15	21	27	35	45	59	78	102	114	144
71	1500	21			7.5	13	27	35	49	61	77	100	143	176	199	253
	1000	14			5.0	8.9	18	23	33	41	52	67	95	117	133	169
	750	11			3.8	6.7	13	17	24	31	39	50	72	88	100	126
80	1500	19				12		31		54		95		154		229
	1000	13				8		21		36		63		103		153
	750	9				6		16		27		47		77		115
90	1500	17				12		29		47		82		142		201
	1000	11				7.7		19		31		55		95		134
	750	8				5.8		14		24		41		71		100

3.9 Data tables – Type B3

Nominal output torque of low speed shaft (kNm)

Type	i _N	Gear unit size													
		712	713	714	715	716	717	718	719	720	721	722	723	724	725
B2	5	0.8		3		9.5		19		30		48.2		70	
	5.6	0.8	1.4	3		9.5	12	19	24	30	35	48.2		70	
	6.3	0.8	1.4	3	6.2	9.5	12	19	24	30	38	52.5	62.8	74	86
	7.1	0.8	1.4	3	6.2	9.5	12	19	24	30	38.8	52.5	62.8	78	89
	8	0.8	1.4	3	6.2	9.5	12	19	24	30	38.6	54	64.5	81	97
	9	0.8	1.4	3	6.2	9.5	12	19	24	30	39.5	55	65.2	81.1	95
	10	0.8	1.4	3	6.2	9.5	12	19	24	30	38	54.6	66.3	81.5	100
	11.2	0.8	1.4	3	6.2	9.5	12	19	24	30	38	56	66.3	85	100.5
	12.5	0.8	1.4	2.9	6.2	9	12	19	24	30	39.5	57	65.9	75	101
	14		1.4	2.7	6.2	9	12	19	24	30	38	52.3	66.3	67.1	101
	16			3	6	9	12	19	23	30	38	47.4	64.5	70	80
	18			3	5.5	9	11.2	19	22	30	34.8	51	51.6	70	86
	20				5.5	9	12	19	23	30	38	51	56.8		86
22.4				5.5		12		23		38		60.3		86	
B3	12.5			3.4		9.5		17		30		53		79	
	14			3.4		10		19		32		58		81	
	16			3.4	6.6	11.9	12	20	21.5	32	39.5	61	67	84	99.4
	18			3.4	6.8	11.9	13.5	21.8	24	34	39.5	63.6	72	86	102
	20			3.4	6.8	11.9	13.5	21.8	27.5	36	39.5	63.6	77	91	105
	22.4			3.4	6.8	11.9	15.5	21.8	27.5	36	45	63.6	79	91	108
	25			3.4	6.8	11.9	16	21.8	27.5	36	47	63.6	79	91	113
	28			3.4	6.8	11.9	16	21.8	27.5	36	47	63.6	79	91	115
	32			3.4	6.8	11.9	16	21.8	27.5	36	47	63.6	79	91	115
	35.5			3.4	6.8	11.9	16	21.8	25.7	36	47	63.6	79	91	115
	40			3.4	6.8	11.9	16	21.8	27.5	36	47	63.6	79	91	115
	45			3.4	6.8	11.9	16	21.8	27.5	36	47	63.6	79	91	115
	50			3.4	6.8	11.9	16	21.8	26.5	36	47	63.6	79	91	115
	56			3.4	6.8	11.9	16	21.4	27.5	36	47	63.6	79	91	115
	63			3.4	6.8	11.9	16	21.8	27.5	36	47	63.6	79	91	115
	71			3.4	6.2	11.9	16	21.8	27.1	36	46	63.6	79	91	115
	80				6.6	11.9	16	21.8	27.5	36	47	61.6	79	91	115
90				6.7	11.9	16	21.8	26.8	36	47	63.6	79	91	115	
B4	100					11.9	16	21.8	27.5	36	45	63.6	79	91	115
	112					11.6	16	21.8	27.5	36	45	63.6	79	91	115
	125					11.9	16	21.8	27.5	36	48	63.6	79	91	115
	140					11.9	16	21.8	27.5	36	48	63.6	79	91	115
	140					11.6	16	21.8	27.5	36	45	63.6	80.5	91	115
	180					11.9	16	21.8	27.5	36	45	63.6	81.5	91	115
	200					11.9	15.7	21.8	27.5	36	45	63.6	81.5	91	115
	224					11.6	16	21.8	27.5	36	48	63.6	80.5	91	115
	250					11.9	16	21.8	27.5	36	48	63.6	79.6	91	115
	280					11.9	16	21.8	27.5	36	48	63.6	80.5	91	115
	315					11.6	16	21.8	27.5	36	48	63.6	80.5	91	115
	355					11.5	16	17.8	27.5	36	45	63.6	79	91	115
	400							14.7	27.5		45		79		115
	450							15.5		19.7		48		79	

3.10 Data tables – Type B4

Nominal power rating P_N (kW)

i_N	n1	n2	Gear unit size													
			712	713	714	715	716	717	718	719	720	721	722	723	724	725
80	1500	19					23		44		71		121		182	
	1000	13					15		29		47		80		121	
	750	9					12		22		35		60		91	
90	1500	17					21		39		65		113		161	
	1000	11					14		26		44		75		107	
	750	8					10		19		33		56		80	
100	1500	15					19	25	34	44	56	71	99	124	144	183
	1000	10					13	16	23	29	38	48	66	83	96	122
	750	8					10	12	17	22	28	36	50	62	72	92
112	1500	13					16	22	31	38	49	66	91	112	126	159
	1000	9					10	15	21	26	33	44	61	75	84	106
	750	7					7.8	11	15	19	25	33	46	56	63	80
125	1500	12					14	20	27	34	45	61	79	99	112	144
	1000	8					10	14	18	23	30	41	52	66	75	96
	750	6					7.2	10	14	17	23	30	39	49	56	72
140	1500	11					13	17	24	31	39	53	69	91	100	126
	1000	7					8.9	11	16	20	26	35	46	60	67	84
	750	5					6.6	9	12	15	20	27	35	45	50	63
160	1500	9					11	15	22	27	35	46	64	80	87	111
	1000	6					7.5	10	14	18	24	31	42	53	58	74
	750	5					5.6	8	11	13	18	23	32	40	44	55
180	1500	8					10	14	19	24	33	40	56	71	80	101
	1000	6					6.8	9.5	13	16	22	27	38	47	54	67
	750	4					5.1	7.1	10	12	16	20	28	35	40	50
200	1500	8					10	12	17	21	28	36	50	65	72	88
	1000	5					6.4	8.0	11	14	19	24	33	43	48	59
	750	4					4.8	6.0	9	11	14	18	25	33	36	44
224	1500	7					7.8	11	15	19	25	35	46	57	63	80
	1000	4					5.2	7.3	10	13	16	23	30	38	42	53
	750	3					3.9	5.5	7.7	10	12	18	23	29	31	40
250	1500	6					7.2	10	14	17	23	30	39	50	56	72
	1000	4					4.8	6.8	9.0	11	15	20	26	33	37	48
	750	3					3.6	5.1	6.8	8.6	11	15	20	25	28	36
280	1500	5					6.6	8.6	12	15	20	27	35	44	50	64
	1000	4					4.4	5.7	8.0	10	13	18	23	29	33	43
	750	3					3.3	4.3	6.0	7.7	10	13	17	22	25	32
315	1500	5					5.5	7.6	11	13	18	25	32	40	44	55
	1000	3					3.7	5.1	7.2	8.9	12	16	21	27	29	37
	750	2					2.7	3.8	5.4	6.7	8.9	12	16	20	22	28
355	1500	4					5.0	7.1	7.7	12	15	20	27	34	39	50
	1000	3					3.4	4.7	5.1	7.9	10	13	18	23	26	34
	750	2					2.5	3.6	3.9	6.0	7.7	10	14	17	20	25
400	1500	4						5.5		11		18		32		44
	1000	3						3.7		7.1		12		21		29
	750	2						2.8		5.3		9		16		22
450	1500	3						5.4		6.7		17		27		40
	1000	2						3.6		4.5		11		18		26
	750	2						2.7		3.4		8.3		13		20

3.10 Data tables – Type B4

Nominal output torque of low speed shaft (kNm)

Type	i _N	Gear unit size													
		712	713	714	715	716	717	718	719	720	721	722	723	724	725
B2	5	0.8		3		9.5		19		30		48.2		70	
	5.6	0.8	1.4	3		9.5	12	19	24	30	35	48.2		70	
	6.3	0.8	1.4	3	6.2	9.5	12	19	24	30	38	52.5	62.8	74	86
	7.1	0.8	1.4	3	6.2	9.5	12	19	24	30	38.8	52.5	62.8	78	89
	8	0.8	1.4	3	6.2	9.5	12	19	24	30	38.6	54	64.5	81	97
	9	0.8	1.4	3	6.2	9.5	12	19	24	30	39.5	55	65.2	81.1	95
	10	0.8	1.4	3	6.2	9.5	12	19	24	30	38	54.6	66.3	81.5	100
	11.2	0.8	1.4	3	6.2	9.5	12	19	24	30	38	56	66.3	85	100.5
	12.5	0.8	1.4	2.9	6.2	9	12	19	24	30	39.5	57	65.9	75	101
	14		1.4	2.7	6.2	9	12	19	24	30	38	52.3	66.3	67.1	101
	16			3	6	9	12	19	23	30	38	47.4	64.5	70	80
	18			3	5.5	9	11.2	19	22	30	34.8	51	51.6	70	86
	20				5.5	9	12	19	23	30	38	51	56.8		86
22.4				5.5		12		23		38		60.3		86	
B3	12.5			3.4		9.5		17		30		53		79	
	14			3.4		10		19		32		58		81	
	16			3.4	6.6	11.9	12	20	21.5	32	39.5	61	67	84	99.4
	18			3.4	6.8	11.9	13.5	21.8	24	34	39.5	63.6	72	86	102
	20			3.4	6.8	11.9	13.5	21.8	27.5	36	39.5	63.6	77	91	105
	22.4			3.4	6.8	11.9	15.5	21.8	27.5	36	45	63.6	79	91	108
	25			3.4	6.8	11.9	16	21.8	27.5	36	47	63.6	79	91	113
	28			3.4	6.8	11.9	16	21.8	27.5	36	47	63.6	79	91	115
	32			3.4	6.8	11.9	16	21.8	27.5	36	47	63.6	79	91	115
	35.5			3.4	6.8	11.9	16	21.8	25.7	36	47	63.6	79	91	115
	40			3.4	6.8	11.9	16	21.8	27.5	36	47	63.6	79	91	115
	45			3.4	6.8	11.9	16	21.8	27.5	36	47	63.6	79	91	115
	50			3.4	6.8	11.9	16	21.8	26.5	36	47	63.6	79	91	115
	56			3.4	6.8	11.9	16	21.4	27.5	36	47	63.6	79	91	115
	63			3.4	6.8	11.9	16	21.8	27.5	36	47	63.6	79	91	115
	71			3.4	6.2	11.9	16	21.8	27.1	36	46	63.6	79	91	115
80				6.6	11.9	16	21.8	27.5	36	47	61.6	79	91	115	
90				6.7	11.9	16	21.8	26.8	36	47	63.6	79	91	115	
B4	100					11.9	16	21.8	27.5	36	45	63.6	79	91	115
	112					11.6	16	21.8	27.5	36	45	63.6	79	91	115
	125					11.9	16	21.8	27.5	36	48	63.6	79	91	115
	140					11.9	16	21.8	27.5	36	48	63.6	79	91	115
	140					11.6	16	21.8	27.5	36	45	63.6	80.5	91	115
	180					11.9	16	21.8	27.5	36	45	63.6	81.5	91	115
	200					11.9	15.7	21.8	27.5	36	45	63.6	81.5	91	115
	224					11.6	16	21.8	27.5	36	48	63.6	80.5	91	115
	250					11.9	16	21.8	27.5	36	48	63.6	79.6	91	115
	280					11.9	16	21.8	27.5	36	48	63.6	80.5	91	115
	315					11.6	16	21.8	27.5	36	48	63.6	80.5	91	115
	355					11.5	16	17.8	27.5	36	45	63.6	79	91	115
	400						14.7		27.5		45		79		115
	450						15.5		19.7		48		79		115

3.10 Data tables – Type B4

Thermal capacity (kW), $n_1 = 750$ RPM

i_N		Gear unit size													
		712	713	714	715	716	717	718	719	720	721	722	723	724	725
80	P _{T1}					26		37		57		129		151	
90	P _{T1}					25		36		58		127		143	
100	P _{T1}					24	29	37	49	55	67	117	118	142	204
112	P _{T1}					20	30	33	45	46	63	111	108	122	180
125	P _{T1}					20	30	33	46	48	62	103	99	110	179
140	P _{T1}					18	28	33	44	45	55	102	101	116	178
160	P _{T1}					17	28	33	44	45	56	101	94	108	164
180	P _{T1}					16	27	29	43	46	53	101	94	111	172
200	P _{T1}					15	24	28	43	44	52	97	92	111	159
224	P _{T1}					18	24	28	38	41	55	97	92	98	171
250	P _{T1}					18	23	25	37	40	52	91	88	93	171
280	P _{T1}					17	26	24	37	39	48	88	89	97	161
315	P _{T1}					15	25	24	33	39	48	88	83	93	151
355	P _{T1}					15	25	24	32	37	45	81	80	97	159
400	P _{T1}						22		31		45		80		151
450	P _{T1}						22		32		44		74		156

Thermal capacity (kW), $n_1 = 1000$ RPM

i_N		Gear unit size													
		712	713	714	715	716	717	718	719	720	721	722	723	724	725
80	P _{T1}					30		44		81		152		187	
90	P _{T1}					29		43		82		149		177	
100	P _{T1}					28	33	44	59	78	83	138	131	176	206
112	P _{T1}					23	34	40	54	65	79	130	119	151	182
125	P _{T1}					23	34	39	56	67	77	121	110	136	181
140	P _{T1}					22	32	39	53	64	69	121	112	143	180
160	P _{T1}					19	32	39	53	63	70	119	105	133	165
180	P _{T1}					19	30	34	52	65	66	119	104	137	174
200	P _{T1}					18	27	34	52	62	65	114	103	137	161
224	P _{T1}					21	27	33	46	57	68	115	103	121	172
250	P _{T1}					20	26	30	45	57	65	107	98	115	172
280	P _{T1}					20	29	29	44	55	59	104	99	120	163
315	P _{T1}					18	29	28	40	54	60	104	92	115	152
355	P _{T1}					17	28	29	39	52	57	95	89	119	161
400	P _{T1}						25		38		56		89		152
450	P _{T1}						25		39		55		83		158

Thermal capacity (kW), $n_1 = 1500$ RPM

i_N		Gear unit size													
		712	713	714	715	716	717	718	719	720	721	722	723	724	725
80	P _{T1}					30		43		79		150		185	
90	P _{T1}					28		42		80		148		175	
100	P _{T1}					27	32	43	58	76	82	137	130	174	204
112	P _{T1}					24	36	42	57	68	83	138	127	160	193
125	P _{T1}					24	35	41	58	71	81	129	117	145	192
140	P _{T1}					23	34	41	56	67	72	128	119	151	191
160	P _{T1}					20	33	41	56	66	73	126	111	141	175
180	P _{T1}					20	32	36	55	68	69	127	110	146	184
200	P _{T1}					19	28	35	55	65	68	121	109	146	170
224	P _{T1}					22	28	34	48	60	72	122	109	129	183
250	P _{T1}					22	27	31	47	60	69	113	104	122	183
280	P _{T1}					21	31	31	46	58	62	110	105	127	173
315	P _{T1}					19	30	30	42	57	63	110	98	122	162
355	P _{T1}					18	30	30	41	55	60	101	94	126	170
400	P _{T1}						26		40		59		94		162
450	P _{T1}						26		41		58		88		167

Thermal capacity for B4V/C4V+ Expansion tank on request
Thermal capacity for C4O/C4U (Full Oil) on request

3.12 Actual ratios – Type B2, B3, B4

Type	i _N	Gear unit size													
		712	713	714	715	716	717	718	719	720	721	722	723	724	725
B2	5	4.916		4.875		5.080		5.049		4.912		4.998		4.798	
	5.6	5.653	5.653	5.489		5.494	5.735	5.571	5.920	5.653	5.425	5.638		5.505	
	6.3	6.181	6.473	6.145	6.268	6.355	6.190	6.345	6.407	6.231	6.145	6.378	6.145	6.158	6.036
	7.1	7.059	7.051	7.000	7.046	7.294	7.138	6.891	7.274	7.128	6.818	6.810	6.765	6.889	6.765
	8	8.118	8.118	7.882	7.866	7.889	7.866	8.000	7.991	8.118	7.784	8.095	7.697	7.905	7.624
	9	8.875	9.294	8.824	9.000	9.125	8.889	9.111	9.200	8.947	8.824	9.158	8.824	8.842	8.667
	10	9.832	10.125	9.750	10.118	10.160	10.250	9.895	10.444	10.235	9.789	9.778	9.714	9.595	9.714
	11.2	11.307	11.307	10.979	11.294	10.988	11.294	11.143	11.474	11.307	11.176	11.276	11.053	11.010	10.947
	12.5	12.362	12.945	12.290	12.536	12.710	12.381	12.690	12.814	12.462	12.290	12.756	12.290	12.316	12.071
	14		14.103	13.232	14.092	14.092	14.277	13.782	14.548	14.256	13.635	13.619	13.531	13.778	13.531
	16			15.765	15.731	15.778	15.731	16.000	15.981	16.235	15.567	16.190	15.395	15.810	15.248
	18			17.647	18.000	18.250	17.778	18.222	18.400	17.895	17.647	18.316	17.647	17.684	17.333
	20				20.235	20.235	20.500	19.789	20.889	20.471	19.579	19.556	19.429		19.429
22.4				22.588		22.588		22.947		22.353		22.105		21.895	
B3	12.5			12.188		12.417		11.865		12.768		12.641		12.304	
	14			13.894		13.903		13.535		13.807		14.230		13.855	
	16			15.708	15.670	15.239	15.622	15.576	15.083	15.653	15.772	15.567	15.801	15.321	15.467
	18			17.206	17.863	17.779	17.490	17.301	17.206	17.887	17.056	17.820	17.788	17.191	17.418
	20			19.787	20.196	20.021	19.172	19.068	19.800	20.319	19.336	19.664	19.459	19.787	19.261
	22.4			22.654	22.122	22.411	22.368	21.753	21.992	21.976	22.096	22.395	22.275	21.809	21.611
	25			24.680	25.440	24.129	25.187	24.455	24.238	25.420	25.100	24.321	24.580	24.949	24.875
	28			28.412	29.127	28.747	28.195	27.298	27.652	29.176	27.147	28.235	27.994	28.412	27.417
	32			32.529	31.731	32.180	30.356	31.235	31.086	31.556	31.401	32.157	30.401	31.316	31.364
	35.5			35.438	36.529	34.647	36.166	35.114	34.701	36.500	36.042	34.923	35.294	35.824	35.718
	40			39.574	41.824	40.041	40.484	39.197	39.706	40.639	38.980	39.328	40.196	39.574	39.368
	45			45.309	45.563	44.822	43.588	43.506	44.637	43.952	45.088	44.790	43.653	43.618	45.035
	50			49.359	50.880	48.258	50.374	48.909	49.827	50.839	50.201	48.642	49.160	49.897	49.750
	56			56.824	58.254	57.495	56.389	54.758	55.305	58.353	54.294	56.471	55.987	56.824	54.835
63			65.059	63.462	64.360	60.712	62.471	62.173	63.111	62.801	64.314	60.803	62.632	62.728	
71			70.875	73.059	69.294	72.332	70.228	69.608	73.000	72.083	69.845	70.588	71.647	71.435	
80				83.647		80.969		79.412		77.961		80.392		78.737	
90				91.125		87.176		89.273		90.176		87.307		90.071	
B4	80					81.260		77.392		80.082		80.192		78.433	
	90					90.962		88.292		86.612		88.487		90.277	
	100					97.936	102.230	99.257	98.380	100.183	98.925	100.777	100.240	99.505	98.601
	112					116.681	114.437	110.798	112.236	114.990	106.991	109.445	110.609	113.828	113.491
	125					130.613	123.210	126.779	126.174	124.366	123.756	127.059	125.972	129.629	125.091
	140					140.626	146.792	142.522	140.845	143.853	142.046	144.706	136.806	142.878	143.098
	160					162.519	164.319	159.095	161.159	160.164	153.629	157.152	158.824	163.445	162.962
	180					181.925	176.917	176.584	181.172	173.224	177.701	176.975	180.882	180.554	179.618
	200					195.872	204.460	198.513	202.239	200.367	197.850	201.555	196.440	199.009	205.474
	224					233.361	228.873	221.596	224.472	229.979	213.983	230.294	221.218	225.243	226.982
	250					261.225	246.420	253.557	252.347	248.732	247.512	254.118	251.943	259.257	250.183
	280					281.253	293.584	285.045	281.690	287.706	284.092	289.412	287.868	285.757	283.163
	315					332.469	328.638	318.189	322.318	316.568	307.257	314.303	317.647	326.890	325.924
	355					357.958	353.834	362.784	362.345	366.171	355.401	368.342	361.765	363.690	359.237
400						418.267		404.478		391.055		392.879		410.947	
450						450.334		461.166		452.329		460.428		457.211	



HELICAL GEAR UNITS

- 4.1 Type H1H – Gear unit dimensions
- 4.2 Type H2H – Gear unit dimensions
- 4.3 Type H2V – Gear unit dimensions
- 4.4 Type H2O – Gear unit dimensions
- 4.5 Type H2U – Gear unit dimensions
- 4.6 Type H2 – Gear unit shaft arrangement views
- 4.7 Type H3H – Gear unit dimensions
- 4.8 Type H3V – Gear unit dimensions
- 4.9 Type H3O – Gear unit dimensions
- 4.10 Type H3U – Gear unit dimensions
- 4.11 Type H3 – Gear unit shaft arrangement views
- 4.12 Type H4H – Gear unit dimensions
- 4.13 Type H4V – Gear unit dimensions
- 4.14 Type H4O – Gear unit dimensions
- 4.15 Type H4U – Gear unit dimensions
- 4.16 Type H4 – Gear unit shaft arrangement views

Helical gear units horizontal mounting position

4.1 Type H1H - Gear unit dimensions, Single stage, Size 712 to 716

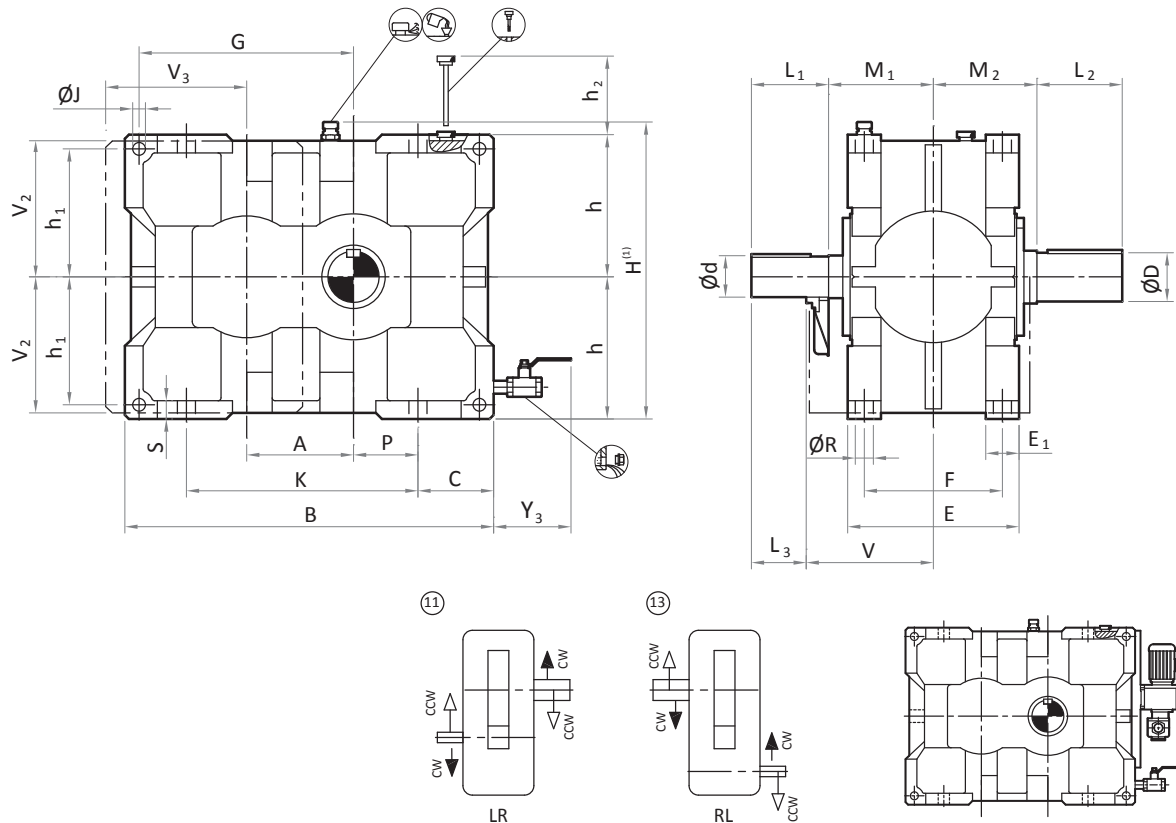

* Remove fan cover before installation

For motor driven pump refer force lubrication details

Size	Input Shaft												Mounting Dimensions				Output Shaft			Weight (kg) ¹⁾	Oil Quantity (Liters) ¹⁾
	I = 1.25 - 2.00			I = 2.24 - 2.80			I = 3.15 - 4.00			I = 4.50 - 5.60											
	d	L ₁	L ₃	d	L ₁	L ₃	d	L ₁	L ₃	d	L ₁	L ₃	M ₁	V	V ₂ ¹⁾	V ₃ ¹⁾	D	L ₂	M ₂		
712	42	100	70	42	100	70	32	90	60	28	85	55	160	190	145	185	45	90	155	80	5
713	42	100	70	42	100	70	32	90	60	28	85	55	160	190	145	195	45	90	155	90	7
714	60	130	100	60	130	100	45	110	80	38	90	60	195	225	195	220	60	120	195	180	9
715	70	150	110	70	150	110	60	130	100	45	110	80	205	245	195	245	80	160	210	225	10
716	85	160	130	85	160	130	60	130	100	50	110	80	230	260	285	290	90	160	220	365	25

Size	Foundation																	
	A	B	C	E	E ₁	F	G	h ^{-0.5}	h ₁	H ¹⁾	h ₂ ¹⁾	J	K	P	R	S	Y ₃ ¹⁾	
712	90	380	75	216	43	180	217	150	132	350	200	14	230	70	14	18	140	
713	100	415	75	216	43	180	242	150	132	350	200	14	260	80	14	18	140	
714	130	500	100	300	58	250	286	200	176	450	260	23	310	90	18	24	150	
715	160	580	100	300	58	250	336	200	176	450	260	23	370	120	18	24	150	
716	186	711	145	346	61	295	416	290	260	630	390	23	410	120	18	35	190	

1) Approximate values

Helical gear units horizontal mounting position

4.1 Type H1H - Gear unit dimensions, Single stage, Size 718 to 725

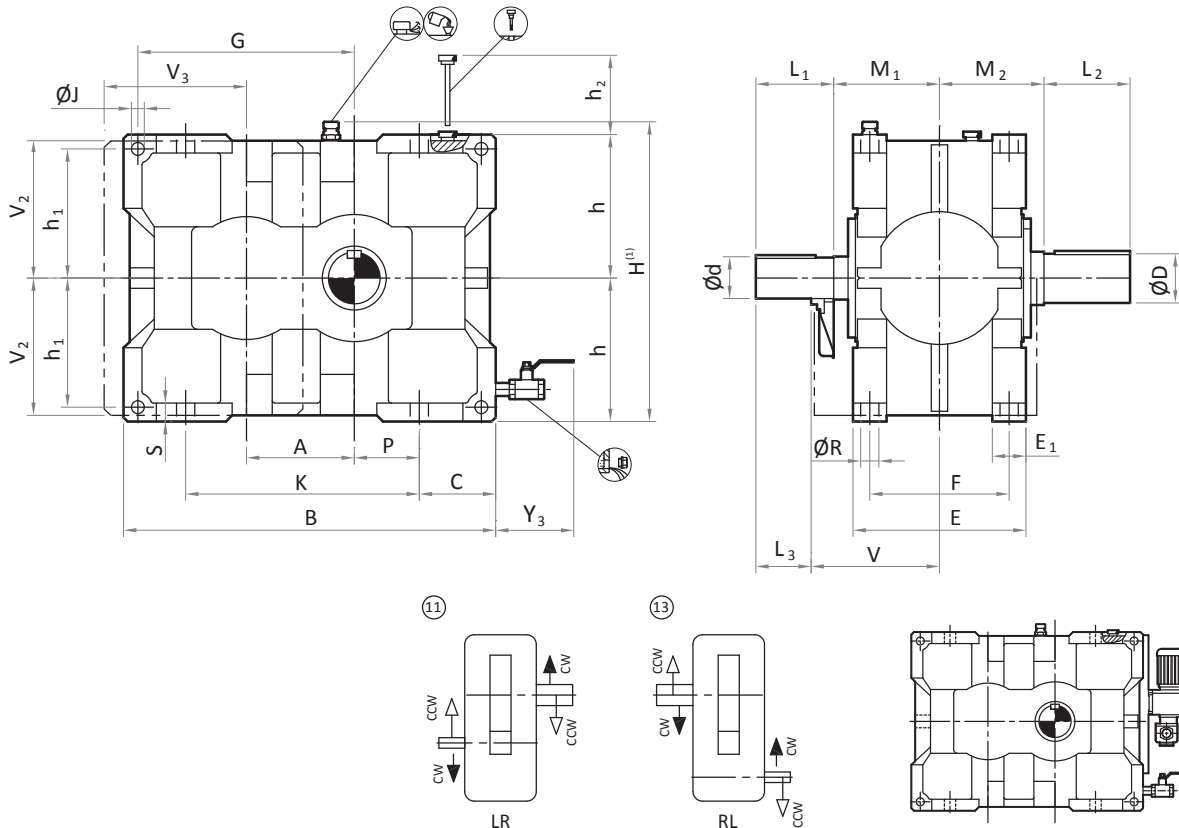

* Remove fan cover before installation

For motor driven pump refer force lubrication details

Size	Input Shaft												Mounting Dimensions				Output Shaft			Weight (Kg) ¹⁾	Oil Quantity (Liters) ¹⁾
	I = 1.25 - 2.00			I = 2.24 - 2.80			I = 3.15 - 4.00			I = 4.50 - 5.60											
	d	L ₁	L ₃	d	L ₁	L ₃	d	L ₁	L ₃	d	L ₁	L ₃	M ₁	V	V ₂ ¹⁾	V ₃ ¹⁾	D	L ₂	M ₂		
718	100	190	160	100	190	160	75	150	120	60	130	100	260	290	342	330	120	210	255	675	49
720	110	190	160	110	190	160	90	170	140	75	150	120	300	330	412	375	135	250	290	1040	78
722	130	230	200	130	230	200	110	190	160	90	170	140	380	410	492	425	170	300	345	1765	135
724	150	230	200	150	230	200	130	230	200	100	190	160	405	435	570	500	200	340	390	2640	187
725	150	230	200	150	230	200	150	230	200	100	190	160	405	435	570	500	210	350	390	2870	193

Size	Foundation																	
	A	B	C	E	E _i	F	G	h ^{-0.5}	h ₁	H ¹⁾	h ₂ ¹⁾	J	K	P	R	S	Y ₃ ¹⁾	
718	232	847	165	422	82	355	497	350	315	750	470	27	520	150	27	45	190	
720	270	955	165	492	98	415	560	420	375	890	560	33	630	190	33	45	245	
722	328	1128	210	620	100	545	648	500	445	1050	665	39	750	220	33	55	225	
724	376	1336	250	660	110	575	776	580	520	1210	780	45	825	250	39	60	215	
725	445	1475	250	660	110	575	845	580	520	1210	780	45	990	320	39	60	215	

1) Approximate values

Helical gear units horizontal mounting position

4.2 Type H2H - Gear unit dimensions, Two stage, Size 714 to 719

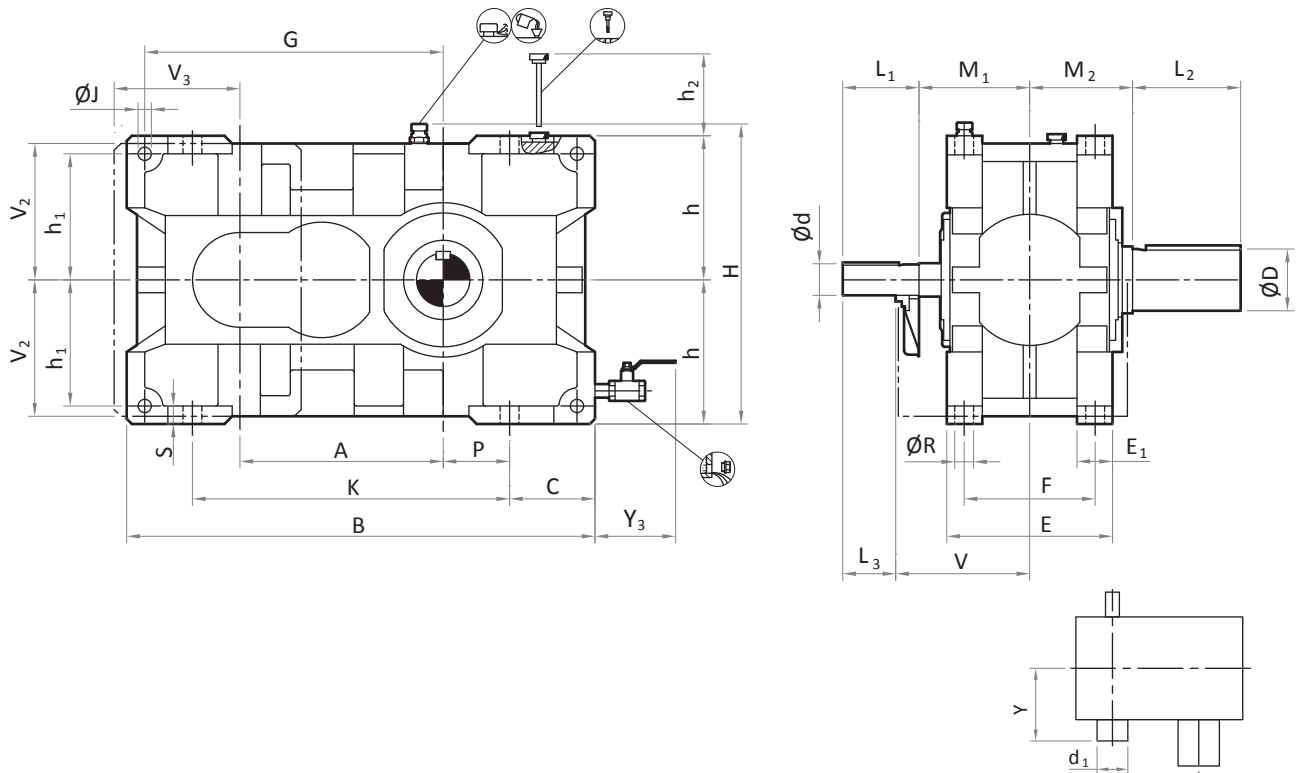

* Remove fan cover before installation

Size	Input Shaft									Mounting Dimensions				Output Shaft			Backstop		Weight (Kg) ¹⁾	Oil Quantity (Liters) ¹⁾
	I = 6.3 - 9			I = 10 - 11.2			I = 12.5 - 18													
	I = 8 - 11.2			I = 12.5 - 14			I = 16 - 22.4													
	d	L ₁	L ₃	d	L ₁	L ₃	d	L ₁	L ₃	M ₁	V	V ₂ ¹⁾	V ₃ ¹⁾	D	L ₂	M ₂	d ₁	Y		
714	42	100	70	32	90	60	28	85	55	170	200	195	195	60	120	150	140	230	165	9
715	42	100	70	32	90	60	28	85	55	170	200	195	195	80	160	150	140	230	195	10
716	60	130	100	50	110	80	38	90	60	215	245	225	220	100	210	170	175	270	300	15
717	60	130	100	50	110	80	38	90	60	215	245	225	220	110	210	170	175	270	350	15
718	60	130	100	60	130	100	50	110	80	215	245	272	250	120	210	200	210	305	520	27
719	60	130	100	60	130	100	50	110	80	215	245	272	250	130	240	200	210	305	590	29

Size	Foundation																
	A	B	C	E	E ₁	F	G	h ^{-0.5}	h ₁	H ¹⁾	h ₂ ¹⁾	J	K	P	R	S	Y ₃ ¹⁾
714	232	570	95	250	56	200	371	200	176	450	300	23	380	80	18	24	150
715	259	632	95	250	56	200	398	200	176	450	300	23	445	115	18	24	150
716	315	750	145	270	55	224	475	230	200	510	405	23	500	100	18	28	180
717	352	827	145	270	55	224	512	230	200	510	405	23	580	140	18	28	180
718	395	910	165	322	69	270	580	280	245	610	415	27	630	130	23	35	180
719	444	1009	165	322	69	270	629	280	245	610	415	27	720	180	23	35	180

1) Approximate values

Helical gear units horizontal mounting position

4.2 Type H2H - Gear unit dimensions, Two stage, Size 720 to 725

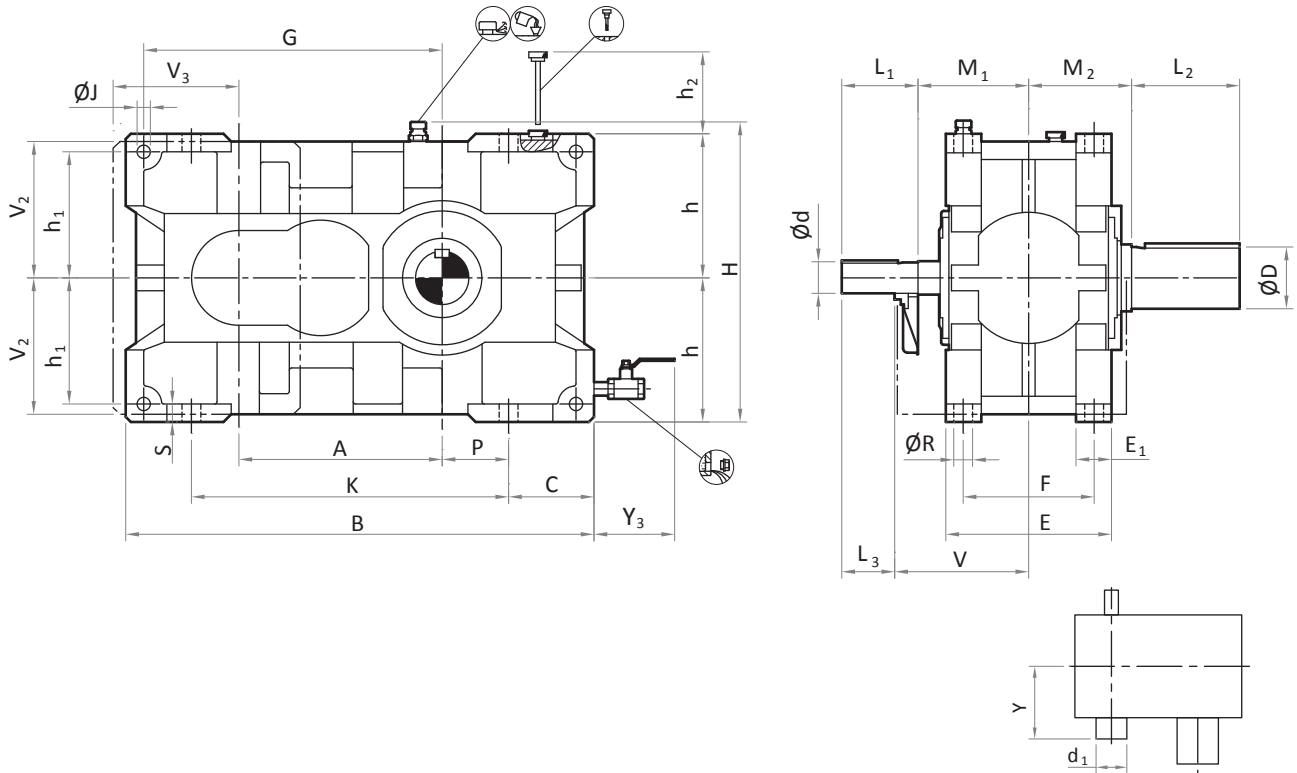

* Remove fan cover before installation

Size	Input Shaft									Mounting Dimensions				Output Shaft			Backstop		Weight (Kg) ¹⁾	Oil Quantity (Liters) ¹⁾
	I = 6.3 - 9			I = 10 - 11.2			I = 12.5 - 18													
	I = 8 - 11.2			I = 12.5 - 14			I = 16 - 22.4													
	d	L ₁	L ₃	d	L ₁	L ₃	d	L ₁	L ₃	M ₁	V	V ₂ ¹⁾	V ₃ ¹⁾	D	L ₂	M ₂	d ₁	Y		
720	80	160	130	80	160	130	60	130	100	255	285	312	300	140	250	240	245	365	865	43
721	80	160	130	80	160	130	60	130	100	255	285	312	300	160	300	240	245	365	985	45
722	90	170	140	90	170	140	70	150	120	285	315	372	340	170	300	270	290	415	1410	73
723	90	170	140	90	170	140	70	150	120	285	315	372	340	180	340	270	290	415	1585	73
724	100	190	160	100	190	160	85	160	130	345	375	430	385	200	340	335	290	465	2235	146
725	100	190	160	100	190	160	85	160	130	345	375	430	385	210	350	335	290	465	2510	133

Size	Foundation																
	A	B	C	E	E ₁	F	G	h ^{-0.5}	h ₁	H ¹⁾	h ₂ ¹⁾	J	K	P	R	S	Y ₃ ¹⁾
720	453	1045	175	400	80	340	670	320	280	690	500	33	730	160	27	40	250
721	502	1144	175	400	80	340	719	320	280	690	500	33	830	210	27	40	250
722	556	1260	210	474	100	400	810	380	330	810	650	39	900	190	33	50	225
723	617	1381	210	474	100	400	871	380	330	810	650	39	1010	250	33	50	225
724	647	1455	220	560	110	475	950	440	380	930	700	45	1055	235	39	60	225
725	712	1585	220	560	110	475	1015	440	380	930	700	45	1190	300	39	60	225

1) Approximate values

Helical gear units vertical mounting position

4.3 Type H2V - Gear unit dimensions, Two stage, Size 714 to 719

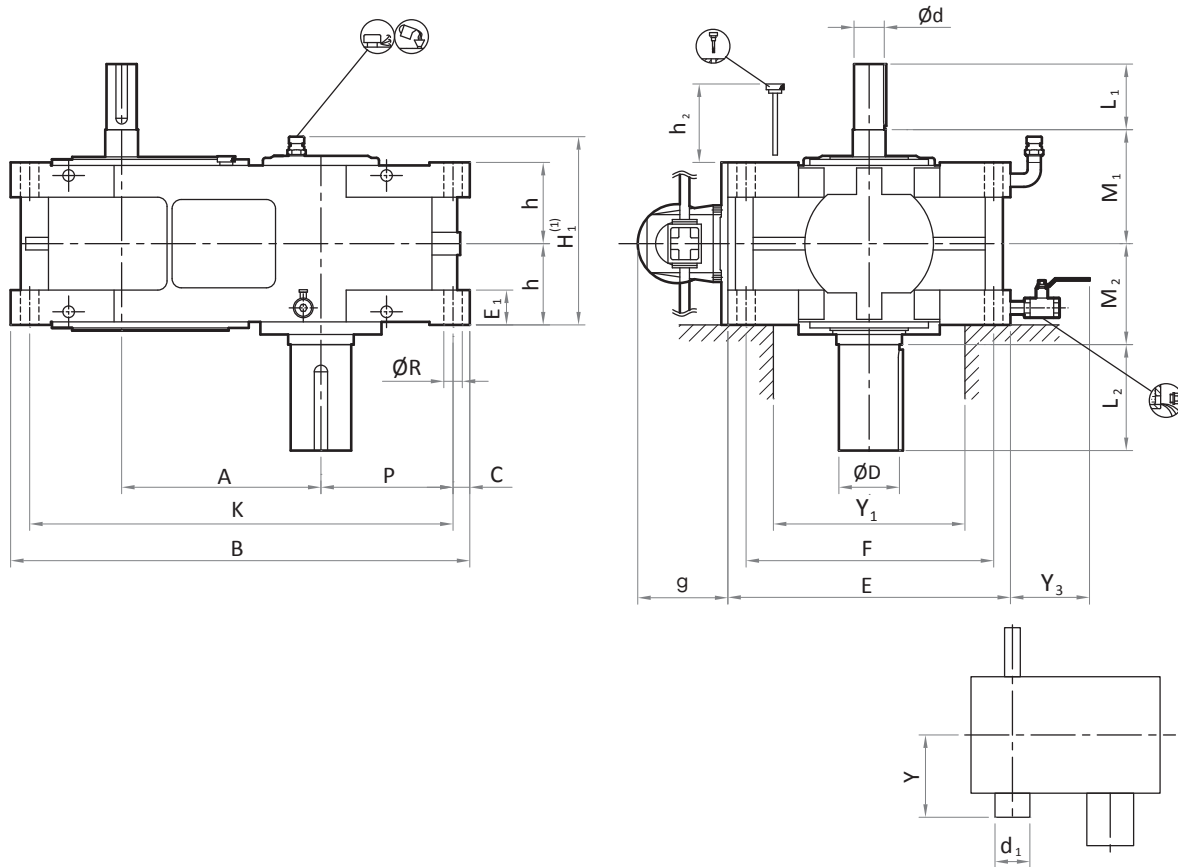

Size	Input Shaft						Mounting Dimensions	Output Shaft			Backstop		Weight (Kg) ¹⁾	Oil Quantity (Liters) ¹⁾	
	l = 6.3 - 9		l = 10 - 11.2		l = 12.5 - 18			M ₁	D	L ₂	M ₂	d ₁			Y
	d	L ₁	d	L ₁	d	L ₁									
714	42	100	32	90	28	85	170	60	120	150	140	230	165	9	
715	42	100	32	90	28	85	170	80	160	150	140	230	195	10	
716	60	130	50	110	38	90	215	100	210	170	175	270	300	14	
717	60	130	50	110	38	90	215	110	210	170	175	270	350	15	
718	60	130	60	130	50	110	215	120	210	200	210	305	520	26	
719	60	130	60	130	50	110	215	130	240	200	210	305	590	28	

Size	Foundation														
	A	B	C	E	E ₁	F	h ^{-0.5}	H ¹⁾	h ₂ ¹⁾	K	P	R	Y ₁ ¹⁾	Y ₃ ¹⁾	g ¹⁾
714	232	570	24	400	56	352	125	380	185	522	151	23	275	160	250
715	259	632	24	400	56	352	125	380	185	584	186	23	275	160	250
716	315	750	30	460	55	400	135	400	200	690	215	23	280	180	350
717	352	827	30	460	55	400	135	400	200	767	255	23	280	180	350
718	395	910	35	560	69	490	161	450	240	840	260	27	350	180	350
719	444	1009	35	560	69	490	161	450	240	939	310	27	350	180	350

1) Approximate values

Helical gear units vertical mounting position

4.3 Type H2V - Gear unit dimensions, Two stage, Size 720 to 725

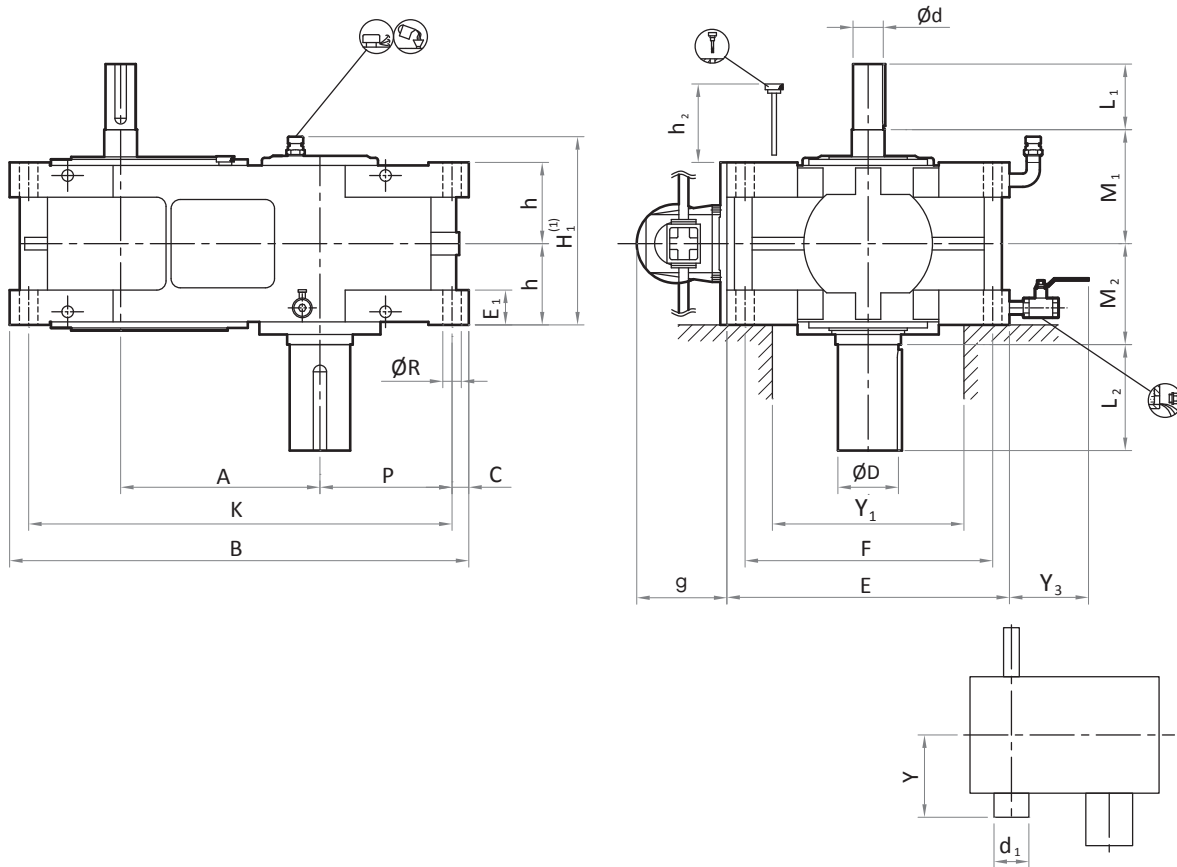

Size	Input Shaft						Mounting Dimensions	Output Shaft			Backstop		Weight (Kg) ¹⁾	Oil Quantity (Liters) ¹⁾	
	l = 6.3 - 9		l = 10 - 11.2		l = 12.5 - 18			M ₁	D	L ₂	M ₂	d ₁			Y
	d	L ₁	d	L ₁	d	L ₁									
720	80	160	80	160	60	130	255	140	250	240	245	365	865	41	
721	80	160	80	160	60	130	255	160	300	240	245	365	985	43	
722	90	170	90	170	70	150	285	170	300	270	290	415	1410	70	
723	90	170	90	170	70	150	285	180	340	270	290	415	1585	70	
724	100	190	100	190	85	160	345	200	340	335	290	465	2235	141	
725	100	190	100	190	85	160	345	210	350	335	290	465	2510	128	

Size	Foundation														
	A	B	C	E	E ₁	F	h ^{-0.5}	H ¹⁾	h ₂ ¹⁾	K	P	R	Y ₁ ¹⁾	Y ₃ ¹⁾	g ¹⁾
720	453	1045	40	640	80	560	200	530	300	965	295	33	420	230	350
721	502	1144	40	640	80	560	200	530	300	1064	345	33	420	230	350
722	556	1260	50	760	100	660	237	600	350	1160	360	39	530	230	350
723	617	1381	50	760	100	660	237	600	350	1281	420	39	530	230	350
724	647	1455	50	880	110	760	280	690	420	1355	405	45	610	230	350
725	712	1585	50	880	110	760	280	690	420	1485	470	45	610	230	350

1) Approximate values

Helical gear units overdriven position

4.4 Type H2O - Gear unit dimensions, Two stage, Size 714 to 719

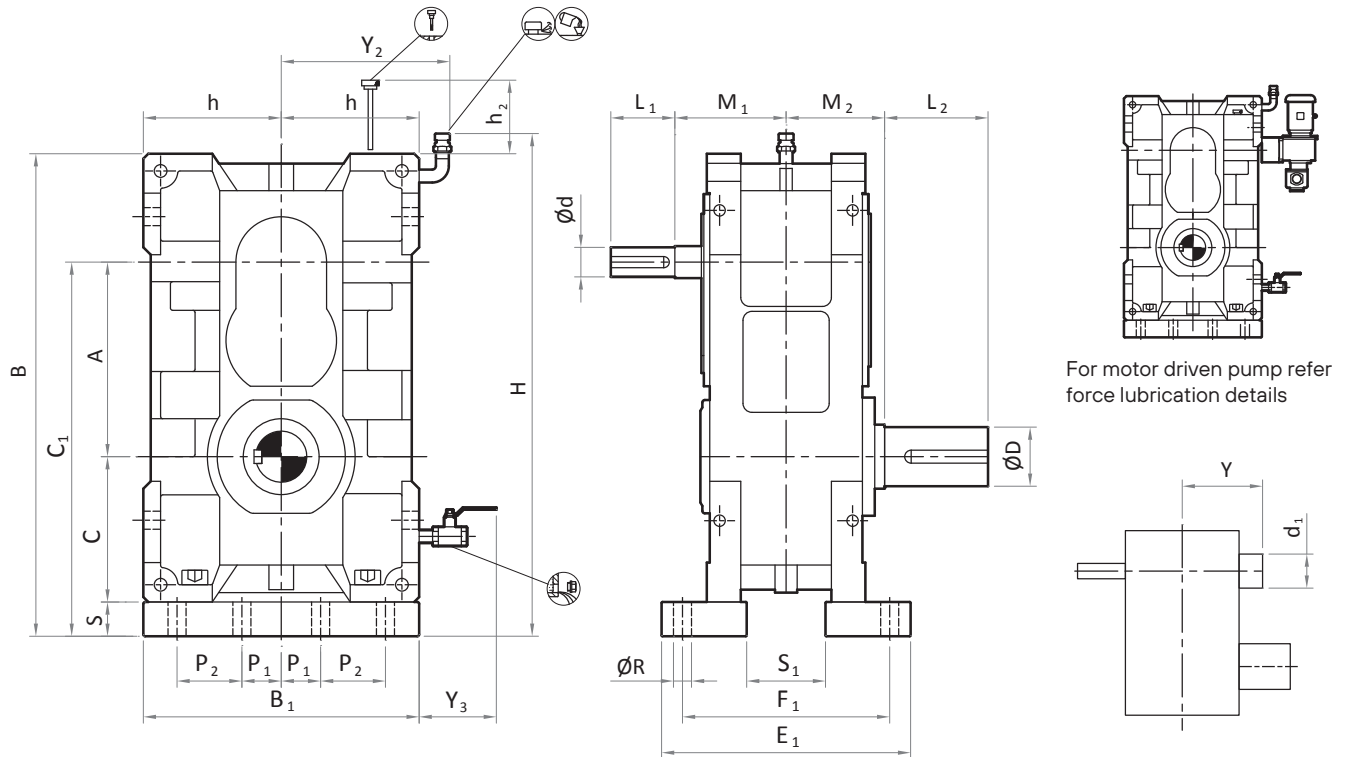

Size	Input Shaft						Mounting Dimensions	Output Shaft			Backstop		Weight (Kg) ¹⁾	Oil Quantity (Liters) ¹⁾	
	l = 6.3 - 9		l = 10 - 11.2		l = 12.5 - 18			M ₁	D	L ₂	M ₂	d ₁			Y
	d	L ₁	d	L ₁	d	L ₁									
714	42	100	32	90	28	85	170	60	120	150	140	230	185	13	
715	42	100	32	90	28	85	170	80	160	150	140	230	215	14	
716	60	130	50	110	38	90	215	100	210	170	175	270	325	21	
717	60	130	50	110	38	90	215	110	210	170	175	270	375	22	
718	60	130	60	130	50	110	215	120	210	200	210	305	570	39	
719	60	130	60	130	50	110	215	130	240	200	210	305	640	42	

Size	Foundation																
	A	B	B ₁	C	C ₁ ^{-0.5}	E ₁	F ₁	h ^{-0.5}	H ¹⁾	h ₂ ¹⁾	P ₁	P ₂	R	S	S ₁	Y ₂ ¹⁾	Y ₃ ¹⁾
714	232	600	400	175	437	340	295	200	690	350	70	80	18	30	120	250	160
715	259	662	400	210	499	340	295	200	750	350	70	80	18	30	120	250	160
716	315	780	460	245	590	390	335	230	875	400	90	90	18	30	150	315	180
717	352	857	460	285	667	390	335	230	950	400	90	90	18	30	150	315	180
718	395	950	560	295	730	470	410	280	1050	450	100	120	23	40	175	370	180
719	444	1049	560	345	829	470	410	280	1150	450	100	120	23	40	175	370	180

1) Approximate values

Helical gear units overdriven position

4.4 Type H2O - Gear unit dimensions, Two stage, Size 720 to 725

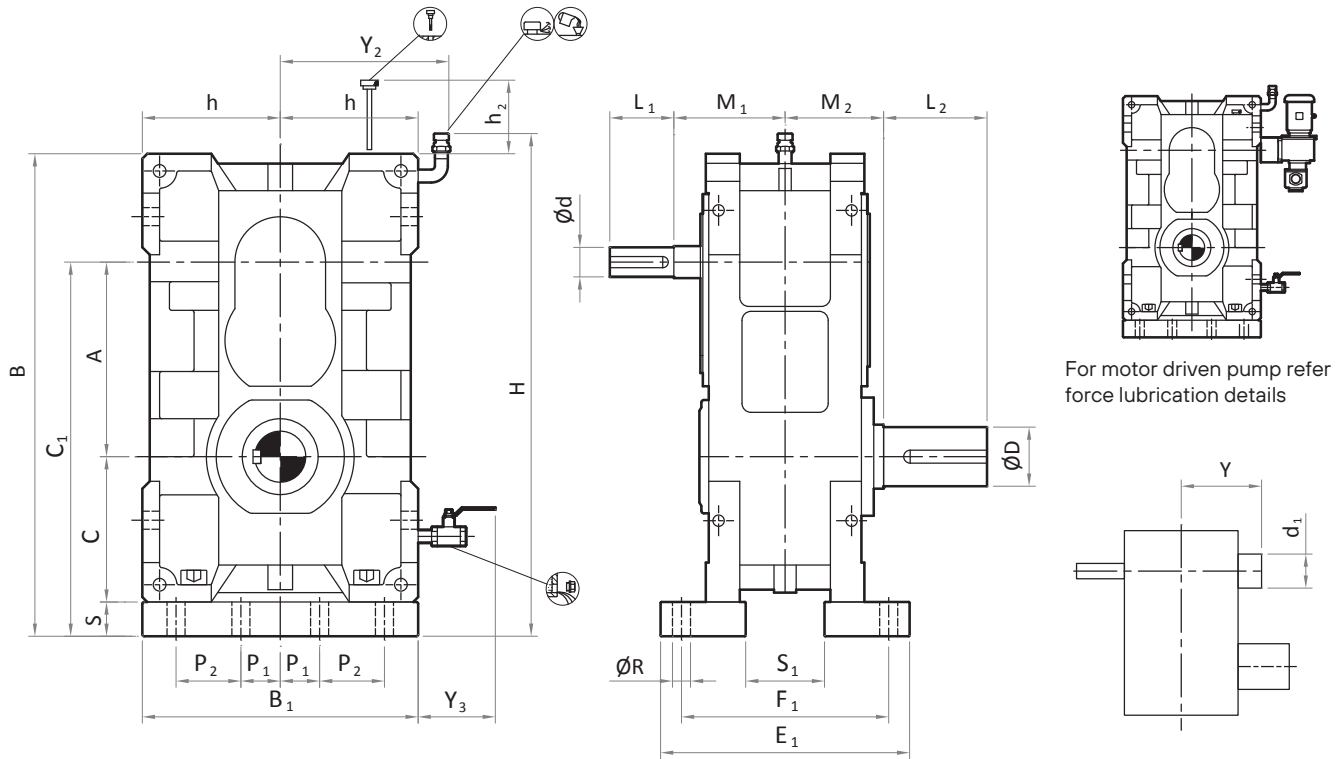

Size	Input Shaft						Mounting Dimensions	Output Shaft				Backstop		Weight (Kg) ¹⁾	Oil Quantity (Liters) ¹⁾
	l = 6.3 - 9		l = 10 - 11.2		l = 12.5 - 18			M ₁	D	L ₂	M ₂	d ₁	Y		
	d	L ₁	d	L ₁	d	L ₁									
720	80	160	80	160	60	130	255	140	250	240	245	365	945	61	
721	80	160	80	160	60	130	255	160	300	240	245	365	1065	65	
722	90	170	90	170	70	150	285	170	300	270	290	415	1550	105	
723	90	170	90	170	70	150	285	180	340	270	290	415	1725	104	
724	100	190	100	190	85	160	345	200	340	335	290	465	2450	211	
725	100	190	100	190	85	160	345	210	350	335	290	465	2725	192	

Size	Foundation																
	A	B	B ₁	C	C ₁ ^{-0.5}	E ₁	F ₁	h ^{-0.5}	H ¹⁾	h ₂ ¹⁾	P ₁	P ₂	R	S	S ₁	Y ₂ ¹⁾	Y ₃ ¹⁾
720	453	1095	640	335	838	540	470	320	1230	600	120	140	27	50	210	410	230
721	502	1194	640	385	937	540	470	320	1330	600	120	140	27	50	210	410	230
722	556	1320	760	400	1016	650	560	380	1450	700	140	180	33	60	245	470	230
723	617	1441	760	460	1137	650	560	380	1580	700	140	180	33	60	245	470	230
724	647	1525	880	455	1172	760	660	440	1650	700	170	200	39	70	300	530	230
725	712	1655	880	520	1302	760	660	440	1780	700	170	200	39	70	300	530	230

1) Approximate values

Helical gear units under driven position

4.5 Type H2U - Gear unit dimensions, Two stage, Size 714 to 719

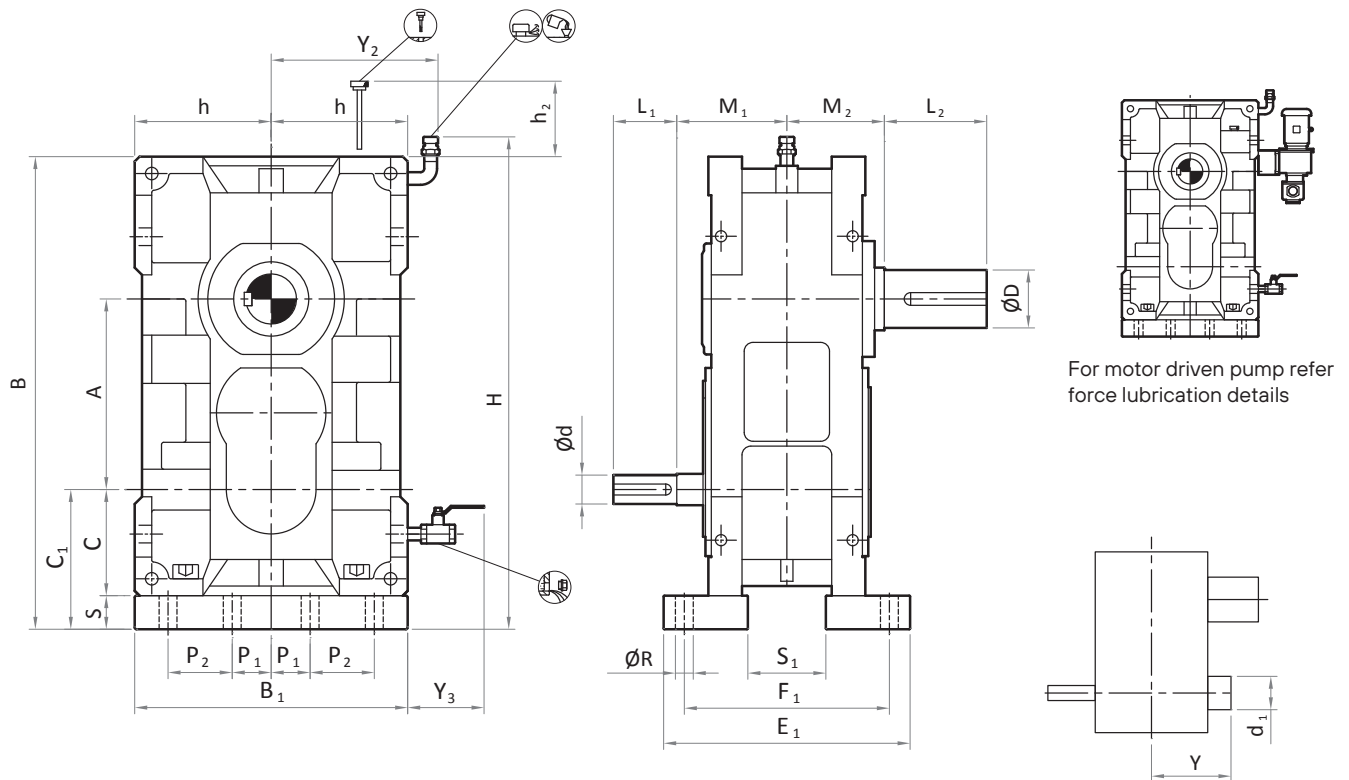

Size	Input Shaft						Mounting Dimensions	Output Shaft			Backstop		Weight (Kg) ¹⁾	Oil Quantity (Liters) ¹⁾	
	l = 6.3 - 9		l = 10 - 11.2		l = 12.5 - 18			M ₁	D	L ₂	M ₂	d ₁			Y
	d	L ₁	d	L ₁	d	L ₁									
714	42	100	32	90	28	85	170	60	120	150	140	230	185	13	
715	42	100	32	90	28	85	170	80	160	150	140	230	215	14	
716	60	130	50	110	38	90	215	100	210	170	175	270	325	21	
717	60	130	50	110	38	90	215	110	210	170	175	270	375	22	
718	60	130	60	130	50	110	215	120	210	200	210	305	570	39	
719	60	130	60	130	50	110	215	130	240	200	210	305	640	42	

Size	Foundation																
	A	B	B ₁	C	C ₁ ^{-0.5}	E ₁	F ₁	h ^{-0.5}	H ¹⁾	h ₂ ¹⁾	P ₁	P ₂	R	S	S ₁	Y ₂ ¹⁾	Y ₃ ¹⁾
714	232	600	400	163	193	340	295	200	690	350	70	80	18	30	120	250	160
715	259	662	400	163	193	340	295	200	750	350	70	80	18	30	120	250	160
716	315	780	460	190	220	390	335	230	875	400	90	90	18	30	150	315	180
717	352	857	460	190	220	390	335	230	950	400	90	90	18	30	150	315	180
718	395	950	560	220	260	470	410	280	1050	450	100	120	23	40	175	370	180
719	444	1049	560	220	260	470	410	280	1150	450	100	120	23	40	175	370	180

1) Approximate values

Helical gear units under driven position

4.5 Type H2U - Gear unit dimensions, Two stage, Size 720 to 725

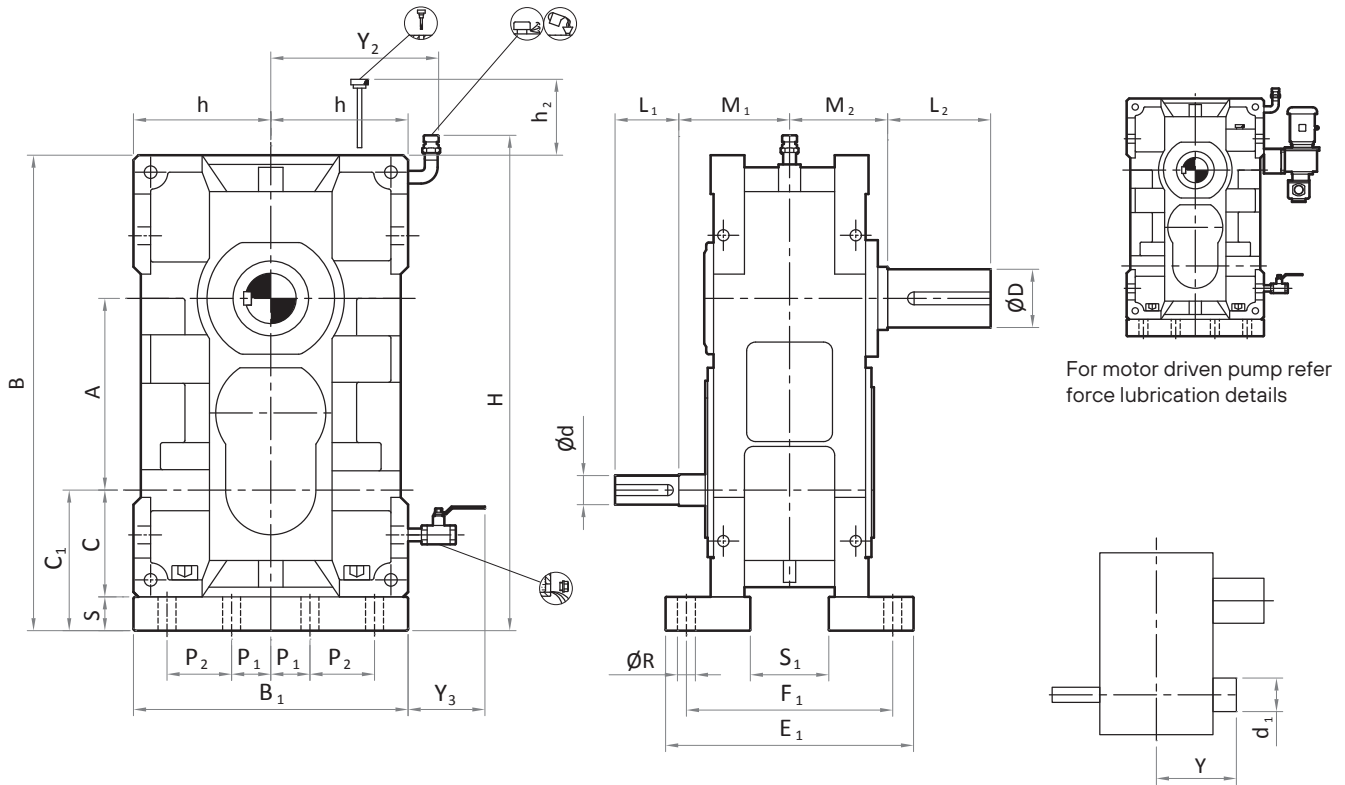

Size	Input Shaft						Mounting Dimensions	Output Shaft				Backstop		Weight (Kg) ¹⁾	Oil Quantity (Liters) ¹⁾
	l = 6.3 - 9		l = 10 - 11.2		l = 12.5 - 18			M ₁	D	L ₂	M ₂	d ₁	Y		
	d	L ₁	d	L ₁	d	L ₁									
720	80	160	80	160	60	130	255	140	250	240	245	365	945	61	
721	80	160	80	160	60	130	255	160	300	240	245	365	1065	65	
722	90	170	90	170	70	150	285	170	300	270	290	415	1550	105	
723	90	170	90	170	70	150	285	180	340	270	290	415	1725	104	
724	100	190	100	190	85	160	345	200	340	335	290	465	2450	211	
725	100	190	100	190	85	160	345	210	350	335	290	465	2725	192	

Size	Foundation																
	A	B	B ₁	C	C ₁ ^{-0.5}	E ₁	F ₁	h ^{-0.5}	H ¹⁾	h ₂ ¹⁾	P ₁	P ₂	R	S	S ₁	Y ₂ ¹⁾	Y ₃ ¹⁾
720	453	1095	640	257	307	540	470	320	1230	600	120	140	27	50	210	410	230
721	502	1194	640	257	307	540	470	320	1330	600	120	140	27	50	210	410	230
722	556	1320	760	304	364	650	560	380	1450	700	140	180	33	60	245	470	230
723	617	1441	760	304	364	650	560	380	1580	700	140	180	33	60	245	470	230
724	647	1525	880	353	423	760	660	440	1650	700	170	200	39	70	300	530	230
725	712	1655	880	353	423	760	660	440	1780	700	170	200	39	70	300	530	230

1) Approximate values

Helical gear units

4.6 Type H2 – Gear unit shaft arrangement views

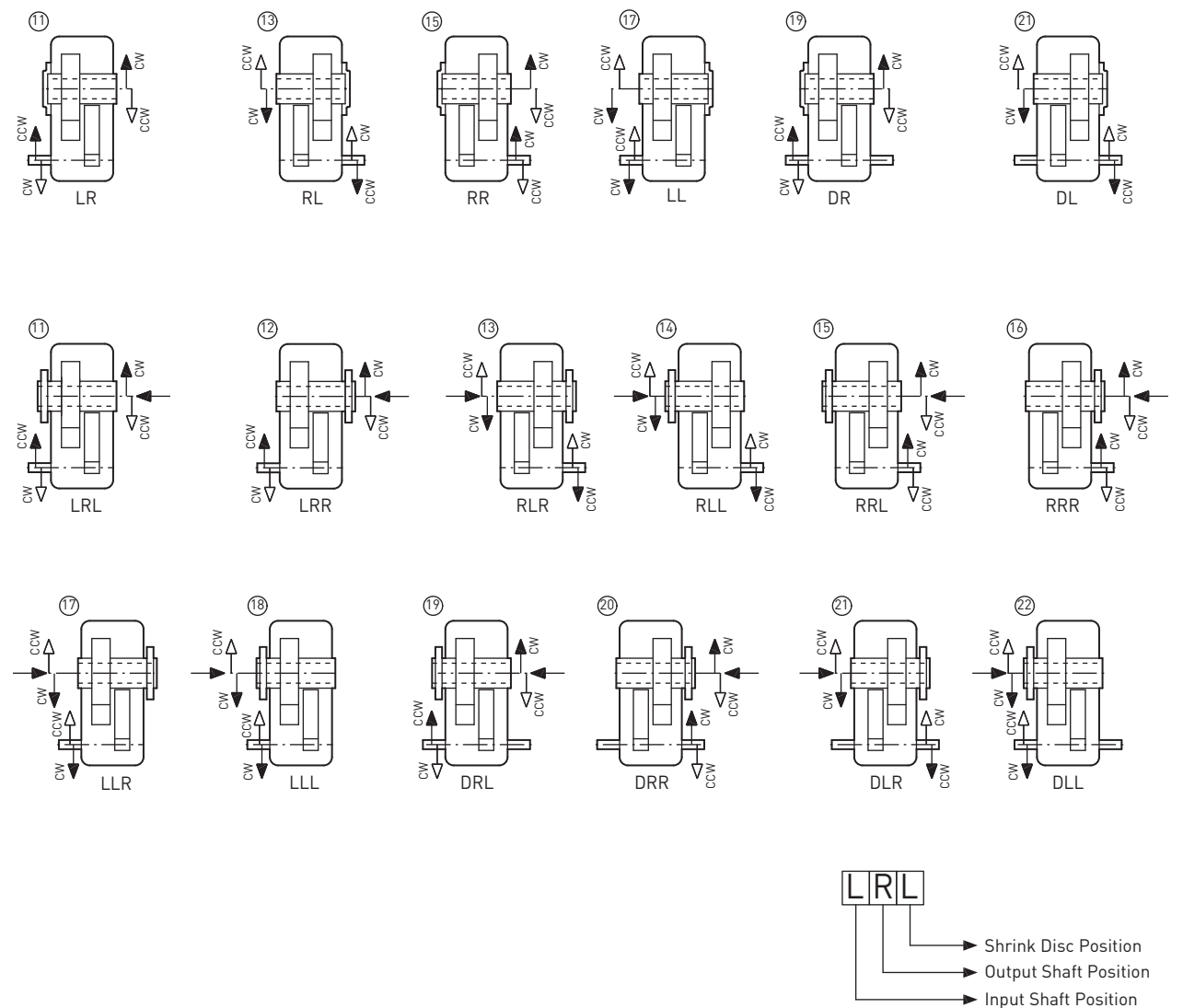
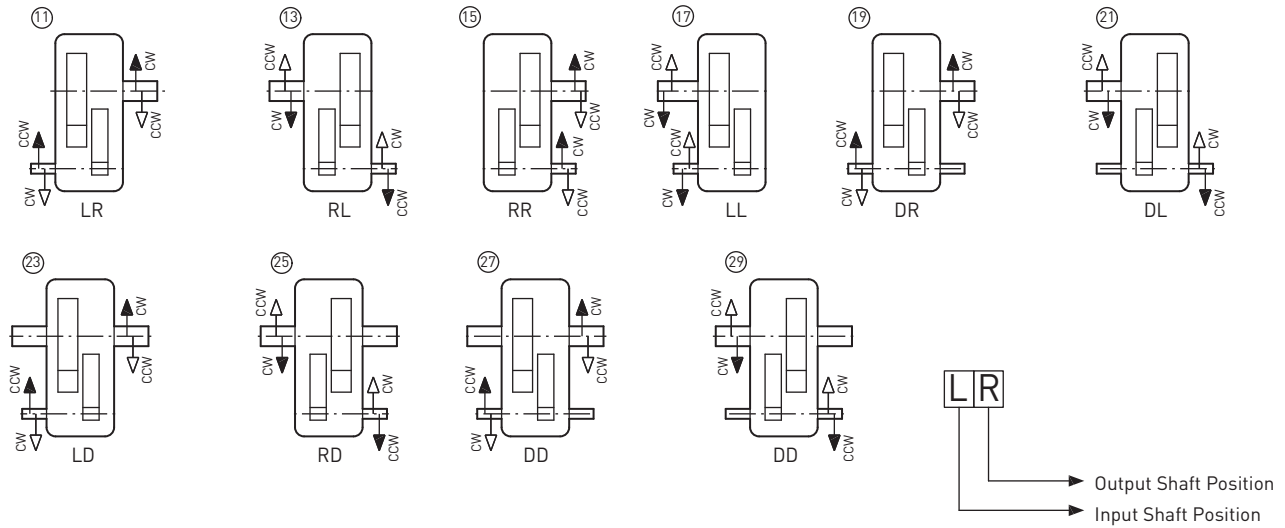

Holdback

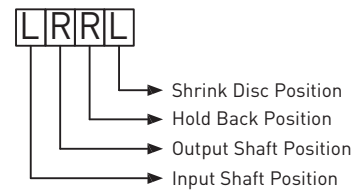
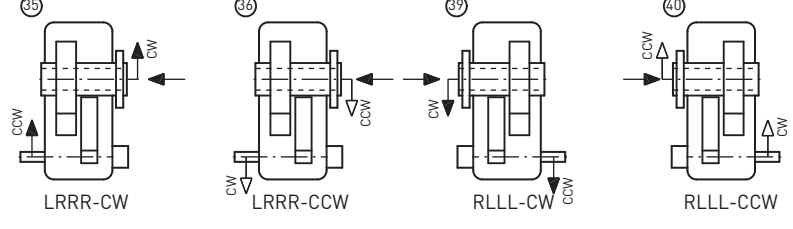
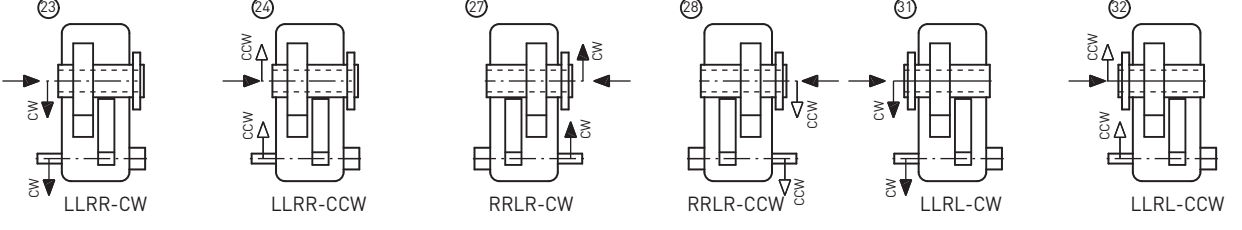
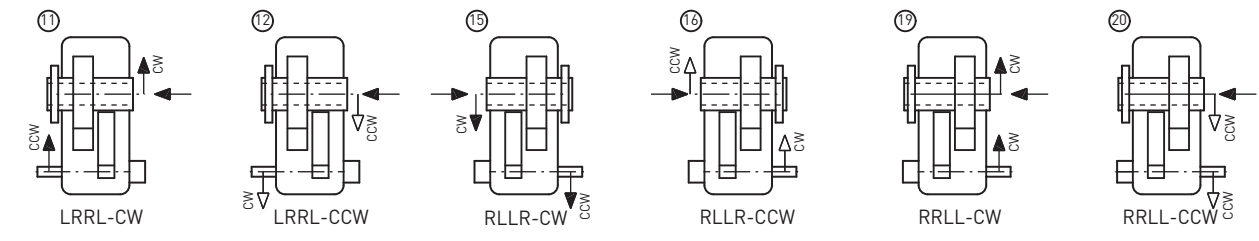
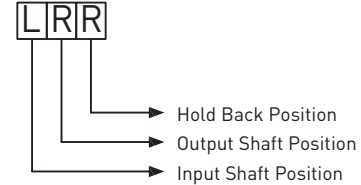
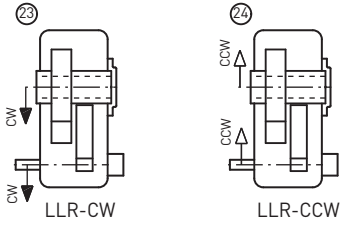
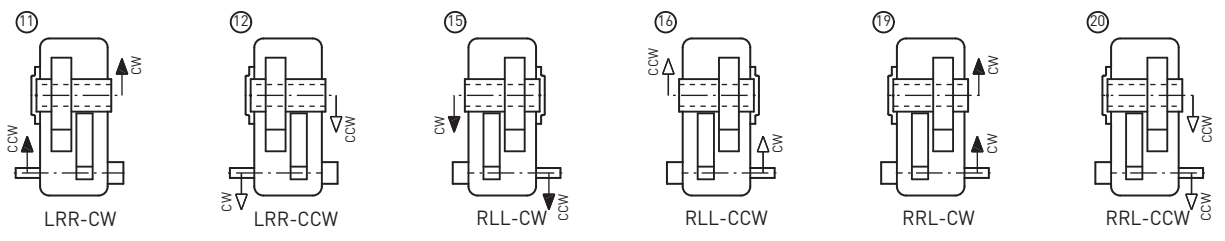
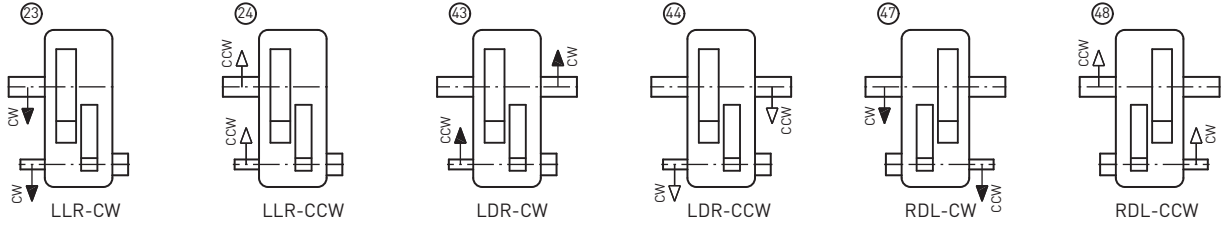
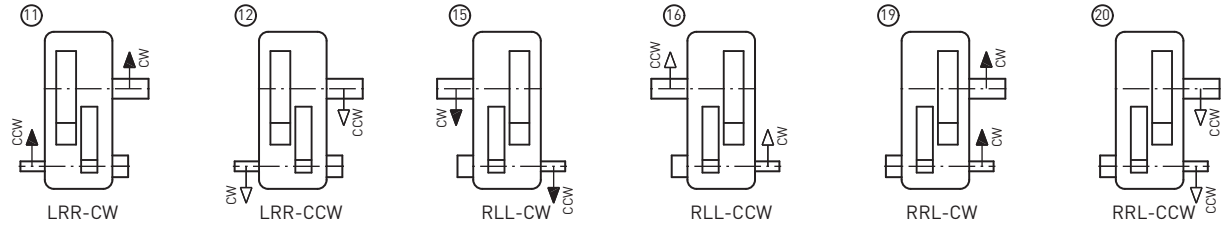

Helical gear units horizontal mounting position

4.7 Type H3H - Gear unit dimensions, Three stage, Size 714 to 719

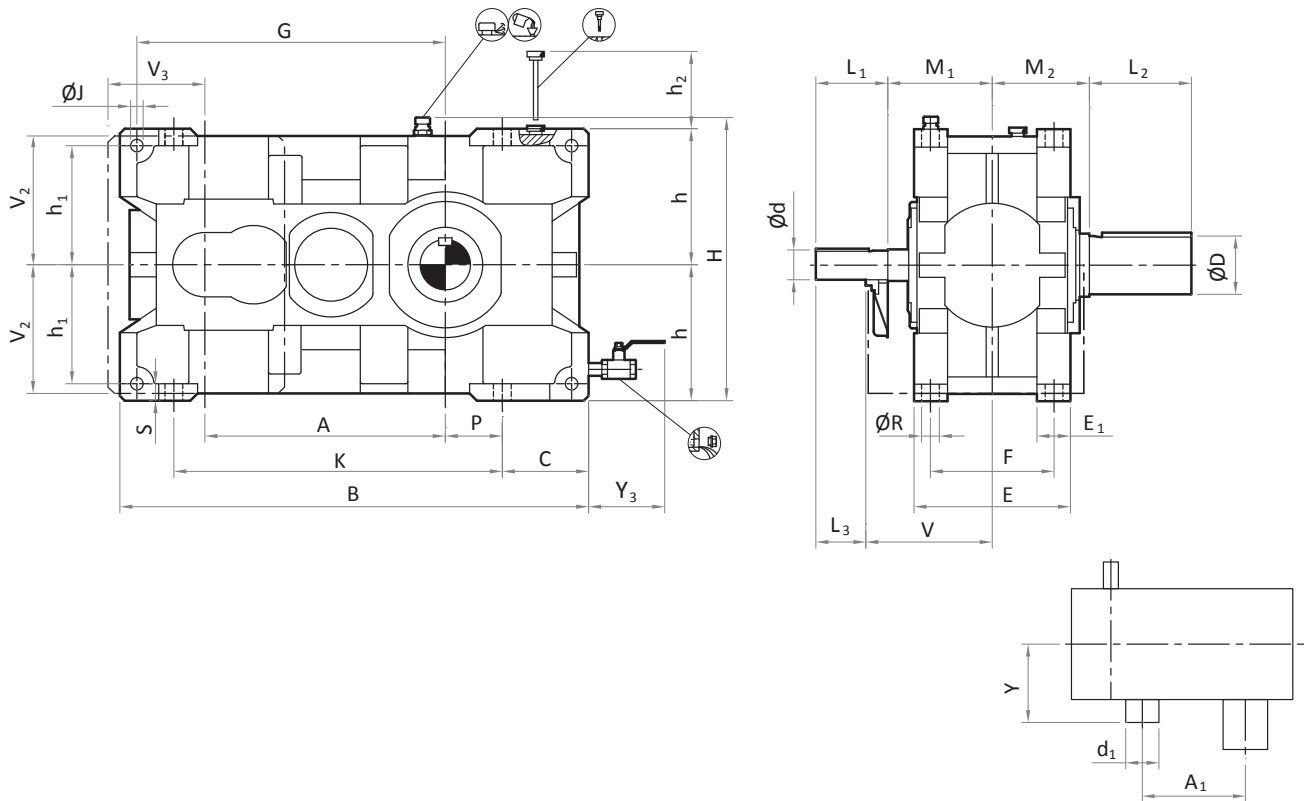

* Remove fan cover before installation

Size	Input Shaft						Mounting Dimensions				Output Shaft			Backstop			Weight (Kg) ¹⁾	Oil Quantity (Liters) ¹⁾
	i = 20 - 45			i = 50 - 71														
	i = 25 - 56			i = 63 - 90														
	d	L ₁	L ₃	d	L ₁	L ₃	M ₁	V	V ₂ ¹⁾	V ₃ ¹⁾	D	L ₂	M ₂	A ₁	d ₁	Y		
714	30	85	55	22	80	50	170	200	195	195	60	120	150	232	132	215	165	8
715	30	85	55	22	80	50	170	200	195	195	80	160	150	259	132	215	195	9
716	42	100	70	32	90	60	210	240	225	220	100	210	170	315	150	245	335	16
717	42	100	70	32	90	60	210	240	225	220	110	210	170	352	150	245	385	18
718	42	100	70	32	90	60	210	240	272	250	120	210	200	395	190	290	565	30
719	42	100	70	32	90	60	210	240	272	250	130	240	200	444	190	290	640	32

Size	Foundation																	
	A	B	C	E	E ₁	F	G	h ^{-0.5}	h ₁	H ¹⁾	h ₂ ¹⁾	J	K	P	R	S	Y ₃ ¹⁾	
714	308	635	95	250	56	200	436	200	176	450	300	23	455	80	18	24	150	
715	335	700	95	250	56	200	466	200	176	450	300	23	515	115	18	24	150	
716	405	805	145	270	55	224	530	230	200	510	405	23	560	100	18	28	180	
717	442	882	145	270	55	224	567	230	200	510	405	23	640	140	18	28	180	
718	495	965	165	322	69	270	635	280	245	610	415	27	695	130	23	35	180	
719	544	1064	165	322	69	270	684	280	245	610	415	27	795	180	23	35	180	

1) Approximate values

Helical gear units horizontal mounting position

4.7 Type H3H - Gear unit dimensions, Three stage, Size 720 to 725

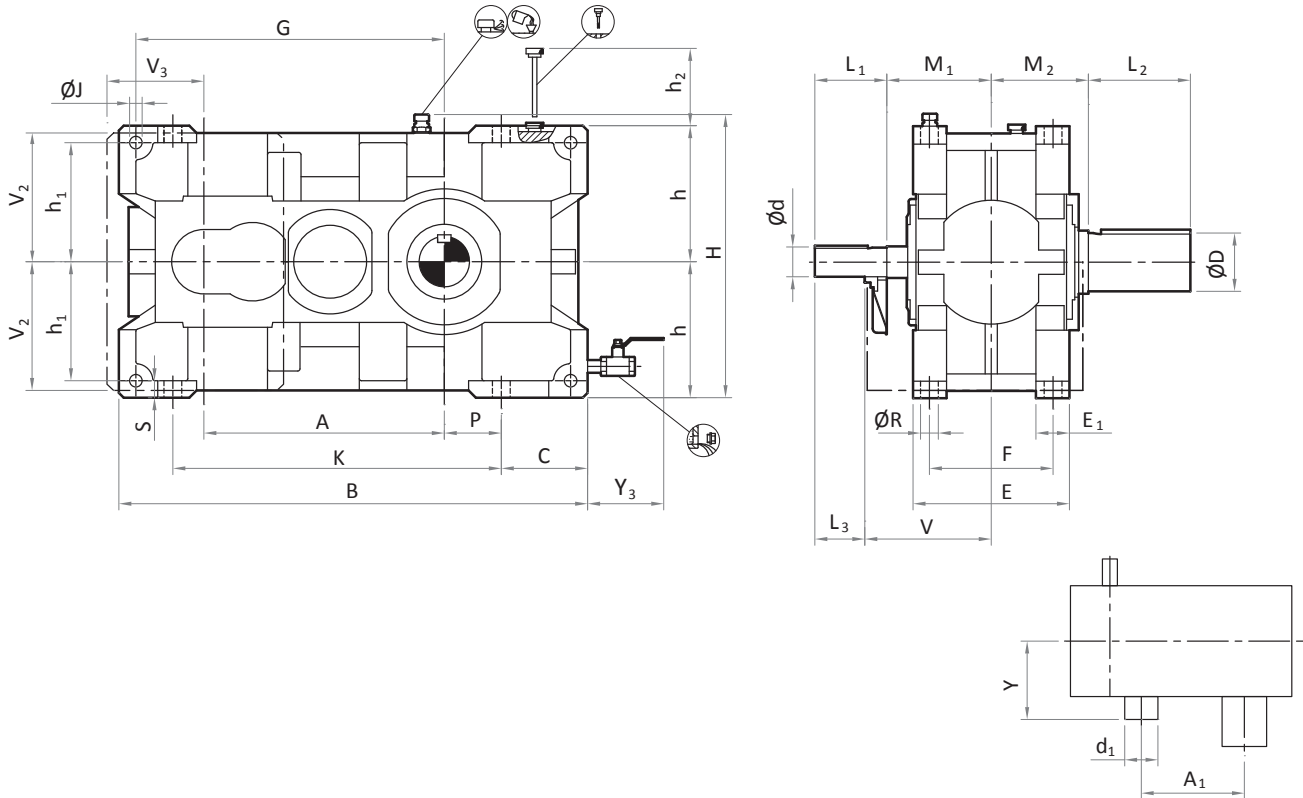

* Remove fan cover before installation

Size	Input Shaft						Mounting Dimensions				Output Shaft			Backstop			Weight (Kg) ¹⁾	Oil Quantity (Liters) ¹⁾
	i = 20 - 45			i = 50 - 71														
	i = 25 - 56			i = 63 - 90														
	d	L ₁	L ₃	d	L ₁	L ₃	M ₁	V	V ₂ ¹⁾	V ₃ ¹⁾	D	L ₂	M ₂	A ₁	d ₁	Y		
720	60	130	100	42	100	70	280	310	312	300	140	250	240	453	210	350	925	49
721	60	130	100	42	100	70	280	310	312	300	160	300	240	502	210	350	1060	50
722	70	150	120	45	110	80	290	320	372	340	170	300	270	556	245	395	1505	89
723	70	150	120	45	110	80	290	320	372	340	180	340	270	617	245	395	1695	89
724	85	160	130	60	130	100	340	370	430	385	200	340	335	647	290	470	2420	165
725	85	160	130	60	130	100	340	370	430	385	210	350	335	712	290	470	2700	166

Size	Foundation																
	A	B	C	E	E ₁	F	G	h ^{-0.5}	h ₁	H ¹⁾	h ₂ ¹⁾	J	K	P	R	S	Y ₃ ¹⁾
720	583	1125	175	400	80	340	750	320	280	690	500	33	830	160	27	40	250
721	632	1224	175	400	80	340	799	320	280	690	500	33	930	210	27	40	250
722	716	1355	210	474	100	400	915	380	330	810	650	39	1000	190	33	50	225
723	777	1476	210	474	100	400	976	380	330	810	650	39	1120	250	33	50	225
724	833	1540	220	560	110	475	1035	440	380	930	700	45	1165	235	39	60	225
725	898	1670	220	560	110	475	1100	440	380	930	700	45	1290	300	39	60	225

1) Approximate values

Helical gear units vertical mounting position

4.8 Type H3V - Gear unit dimensions, Three stage, Size 714 to 719

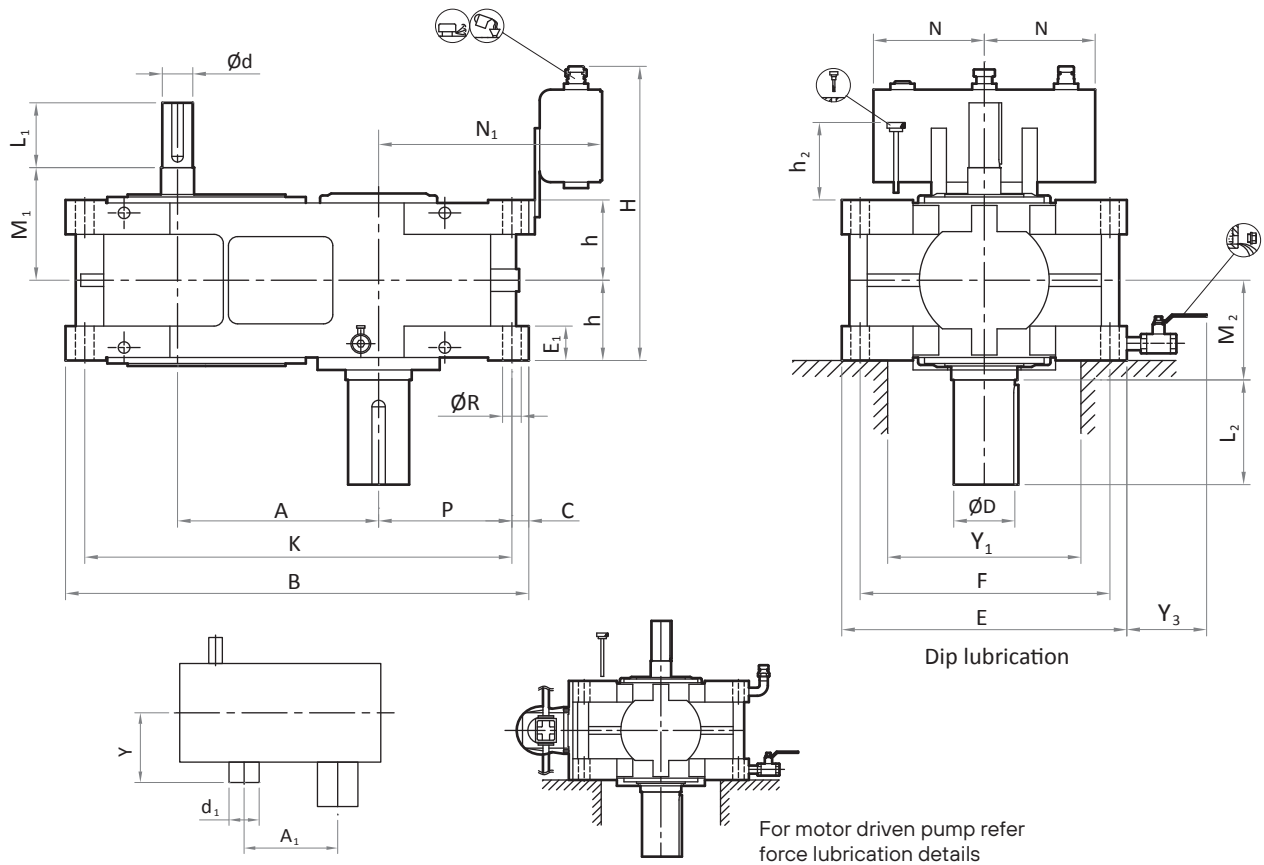

Size	Input Shaft				Mounting Dimensions	Output Shaft			Backstop			Weight (Kg) ¹⁾	Oil Quantity (Liters) ¹⁾
	i = 20 - 45		i = 50 - 71			D	L ₂	M ₂	A ₁	d ₁	Y		
	i = 25 - 56		i = 63 - 90										
	d	L ₁	d	L ₁		M ₁							
714	30	85	22	80	170	60	120	150	232	132	215	165	17
715	30	85	22	80	170	80	160	150	259	132	215	195	19
716	42	100	32	90	210	100	210	170	315	150	245	335	34
717	42	100	32	90	210	110	210	170	352	150	245	385	38
718	42	100	32	90	210	120	210	200	395	190	290	565	61
719	42	100	32	90	210	130	240	200	444	190	290	640	66

Size	Foundation															
	A	B	C	E	E ₁	F	h ^{-0.5}	H ¹⁾	h ₂ ¹⁾	K	N	P	R	Y ₁ ¹⁾	Y ₃ ¹⁾	N ₁
714	308	635	24	400	56	352	125	480	185	587	190	151	23	275	160	325
715	335	700	24	400	56	352	125	480	185	652	190	186	23	275	160	360
716	405	805	30	460	55	400	135	500	200	745	190	215	23	280	180	395
717	442	882	30	460	55	400	135	500	200	822	190	255	23	280	180	435
718	495	965	35	560	69	490	161	550	240	895	190	260	27	350	180	445
719	544	1064	35	560	69	490	161	550	240	994	190	310	27	350	180	495

1) Approximate values

Helical gear units vertical mounting position

4.8 Type H3V - Gear unit dimensions, Three stage, Size 720 to 725

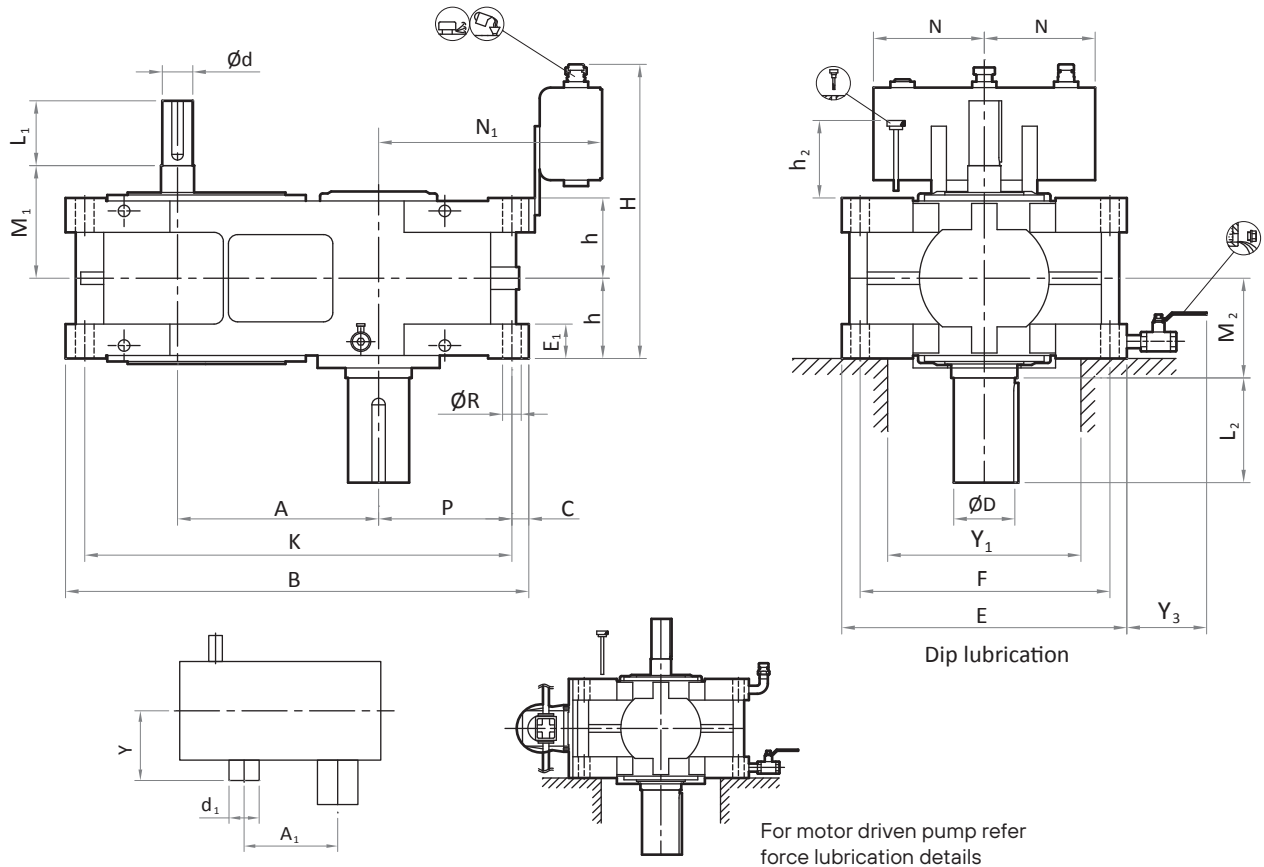

Size	Input Shaft				Mounting Dimensions	Output Shaft			Backstop			Weight (Kg) ¹⁾	Oil Quantity (Liters) ¹⁾
	i = 20 - 45		i = 50 - 71			D	L ₂	M ₂	A ₁	d ₁	Y		
	i = 25 - 56		i = 63 - 90										
	d	L ₁	d	L ₁		M ₁							
720	60	130	42	100	280	140	250	240	453	210	350	925	102
721	60	130	42	100	280	160	300	240	502	210	350	1060	103
722	70	150	45	110	290	170	300	270	556	245	395	1505	184
723	70	150	45	110	290	180	340	270	617	245	395	1695	184
724	85	160	60	130	340	200	340	335	647	290	470	2420	341
725	85	160	60	130	340	210	350	335	712	290	470	2700	343

Size	Foundation															
	A	B	C	E	E ₁	F	h ^{-0.5}	H ¹⁾	h ₂ ¹⁾	K	N	P	R	Y ₁ ¹⁾	Y ₃ ¹⁾	N ₁
720	583	1125	40	640	80	560	200	750	300	1045	300	295	33	420	230	550
721	632	1224	40	640	80	560	200	750	300	1144	300	345	33	420	230	600
722	716	1355	40	760	100	660	237	820	350	1275	300	360	39	530	230	615
723	777	1476	40	760	100	660	237	820	350	1396	300	420	39	530	230	675
724	833	1540	50	880	110	760	280	900	420	1440	300	405	45	610	230	675
725	898	1670	50	880	110	760	280	900	420	1570	300	470	45	610	230	735

1) Approximate values

Helical gear units over driven position

4.9 Type H30 - Gear unit dimensions, Three stage, Size 714 to 719

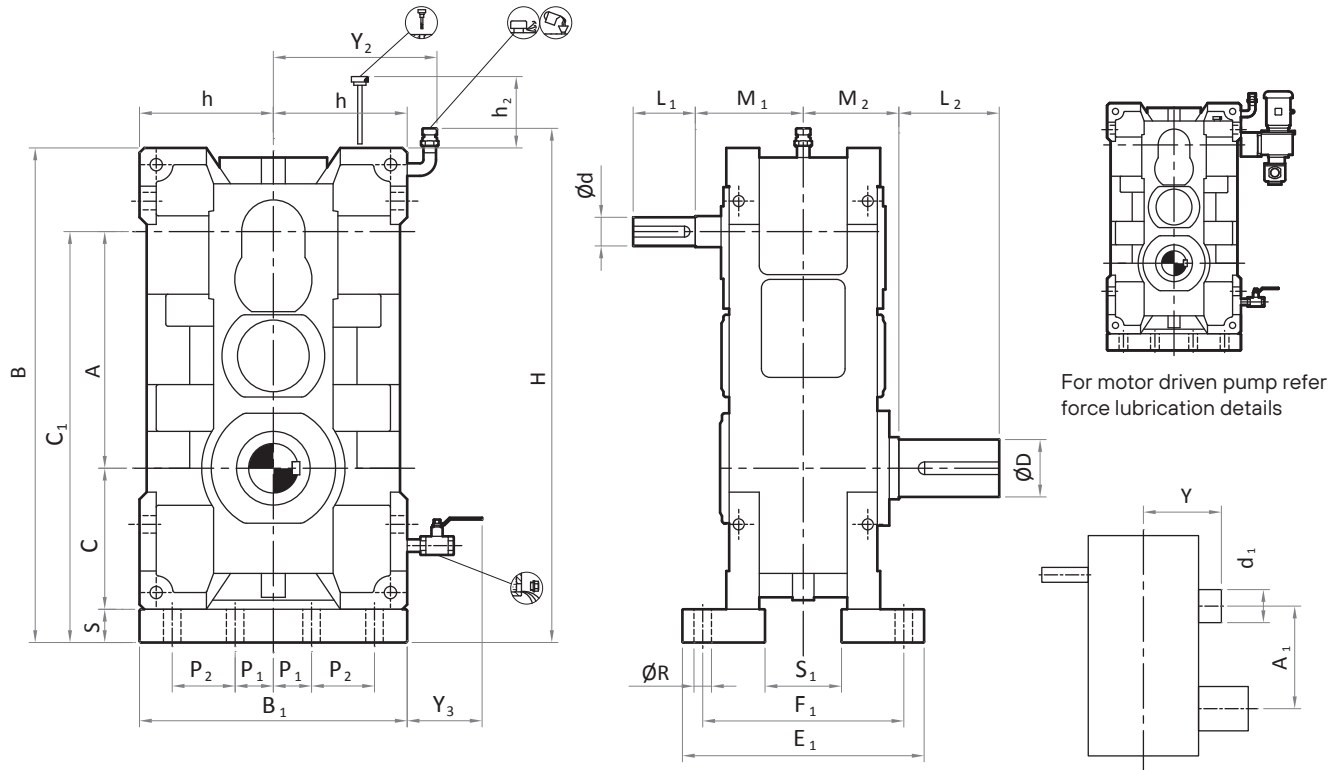

Size	Input Shaft				Mounting Dimensions	Output Shaft			Backstop			Weight (Kg) ¹⁾	Oil Quantity (Liters) ¹⁾	
	i = 20 - 45		i = 50 - 71			M ₁	D	L ₂	M ₂	A ₁	d ₁			Y
	i = 25 - 56		i = 63 - 90											
	d	L ₁	d	L ₁		D	L ₂	M ₂	A ₁	d ₁	Y			
714	30	85	22	80	170	60	120	150	232	132	215	185	12	
715	30	85	22	80	170	80	160	150	259	132	215	215	13	
716	42	100	32	90	210	100	210	170	315	150	245	360	24	
717	42	100	32	90	210	110	210	170	352	150	245	410	26	
718	42	100	32	90	210	120	210	200	395	190	290	615	43	
719	42	100	32	90	210	130	240	200	444	190	290	690	46	

Size	Foundation																
	A	B	B ₁	C	C ₁ ^{-0.5}	E ₁	F ₁	h ^{-0.5}	H ¹⁾	h ₂ ¹⁾	P ₁	P ₂	R	S	S ₁	Y ₂ ¹⁾	Y ₃ ¹⁾
714	308	665	400	175	513	340	295	200	800	350	70	80	18	30	120	250	160
715	335	730	400	210	575	340	295	200	850	350	70	80	18	30	120	250	160
716	405	835	460	245	680	390	335	230	950	400	90	90	18	30	150	315	180
717	442	912	460	285	757	390	335	230	1025	400	90	90	18	30	150	315	180
718	495	1005	560	295	830	470	410	280	1125	450	100	120	23	40	175	370	180
719	544	1104	560	345	929	470	410	280	1220	450	100	120	23	40	175	370	180

1) Approximate values

Helical gear units over driven position

4.9 Type H30 - Gear unit dimensions, Three stage, Size 720 to 725

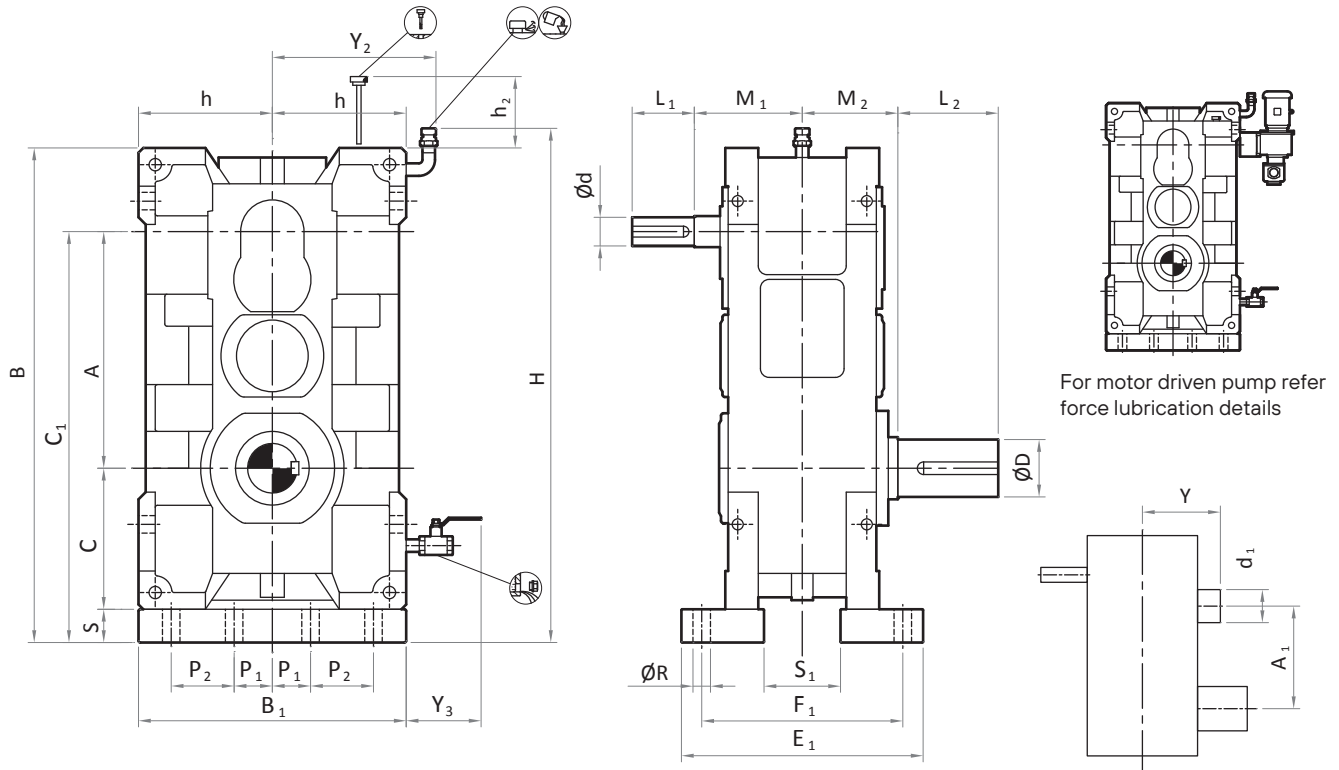

Size	Input Shaft				Mounting Dimensions	Output Shaft			Backstop			Weight (Kg) ¹⁾	Oil Quantity (Liters) ¹⁾	
	i = 20 - 45		i = 50 - 71			M ₁	D	L ₂	M ₂	A ₁	d ₁			Y
	i = 25 - 56		i = 63 - 90											
	d	L ₁	d	L ₁		D	L ₂	M ₂	A ₁	d ₁	Y			
720	60	130	42	100	280	140	250	240	453	210	350	1005	71	
721	60	130	42	100	280	160	300	240	502	210	350	1140	71	
722	70	150	45	110	290	170	300	270	556	245	395	1645	128	
723	70	150	45	110	290	180	340	270	617	245	395	1835	128	
724	85	160	60	130	340	200	340	335	647	290	470	2635	237	
725	85	160	60	130	340	210	350	335	712	290	470	2915	239	

Size	Foundation																
	A	B	B ₁	C	C ₁ ^{-0.5}	E ₁	F ₁	h ^{-0.5}	H ¹⁾	h ₂ ¹⁾	P ₁	P ₂	R	S	S ₁	Y ₂ ¹⁾	Y ₃ ¹⁾
720	583	1175	640	335	968	540	470	320	1340	600	120	140	27	50	210	410	230
721	632	1274	640	385	1067	540	470	320	1430	600	120	140	27	50	210	410	230
722	716	1415	760	400	1176	650	560	380	1580	700	140	180	33	60	245	470	230
723	777	1536	760	460	1297	650	560	380	1700	700	140	180	33	60	245	470	230
724	833	1610	880	455	1358	760	660	440	1770	700	170	200	39	70	300	530	230
725	898	1740	880	520	1488	760	660	440	1900	700	170	200	39	70	300	530	230

1) Approximate values

Helical gear units under driven position

4.10 Type H3U - Gear unit dimensions, Three stage, Size 714 to 719

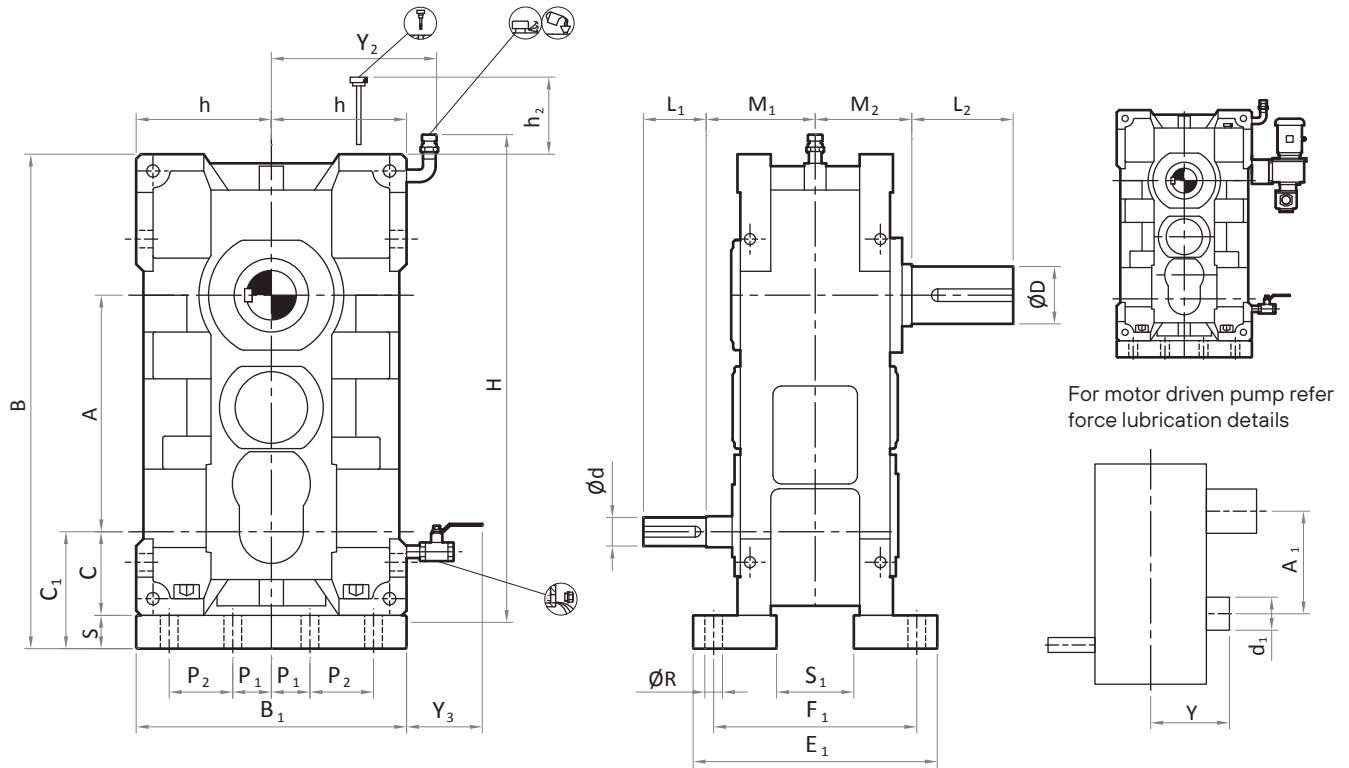

Size	Input Shaft				Mounting Dimensions	Output Shaft			Backstop			Weight (Kg) ¹⁾	Oil Quantity (Liters) ¹⁾	
	i = 20 - 45		i = 50 - 71			M ₁	D	L ₂	M ₂	A ₁	d ₁			Y
	i = 25 - 56		i = 63 - 90											
	d	L ₁	d	L ₁		ØR	S ₁	F ₁	E ₁					
714	30	85	22	80	170	60	120	150	232	132	215	185	12	
715	30	85	22	80	170	80	160	150	259	132	215	215	13	
716	42	100	32	90	210	100	210	170	315	150	245	360	24	
717	42	100	32	90	210	110	210	170	352	150	245	410	26	
718	42	100	32	90	210	120	210	200	395	190	290	615	43	
719	42	100	32	90	210	130	240	200	444	190	290	690	46	

Size	Foundation																
	A	B	B ₁	C	C ₁ ^{-0.5}	E ₁	F ₁	h ^{-0.5}	H ¹⁾	h ₂ ¹⁾	P ₁	P ₂	R	S	S ₁	Y ₂ ¹⁾	Y ₃ ¹⁾
714	308	665	400	152	182	340	295	200	800	350	70	80	18	30	120	250	160
715	335	730	400	155	185	340	295	200	850	350	70	80	18	30	120	250	160
716	405	835	460	155	185	390	335	230	950	400	90	90	18	30	150	315	180
717	442	912	460	155	185	390	335	230	1025	400	90	90	18	30	150	315	180
718	495	1005	560	175	215	470	410	280	1125	450	100	120	23	40	175	370	180
719	544	1104	560	175	215	470	410	280	1220	450	100	120	23	40	175	370	180

1) Approximate values

Helical gear units under driven position

4.10 Type H3U - Gear unit dimensions, Three stage, Size 720 to 725

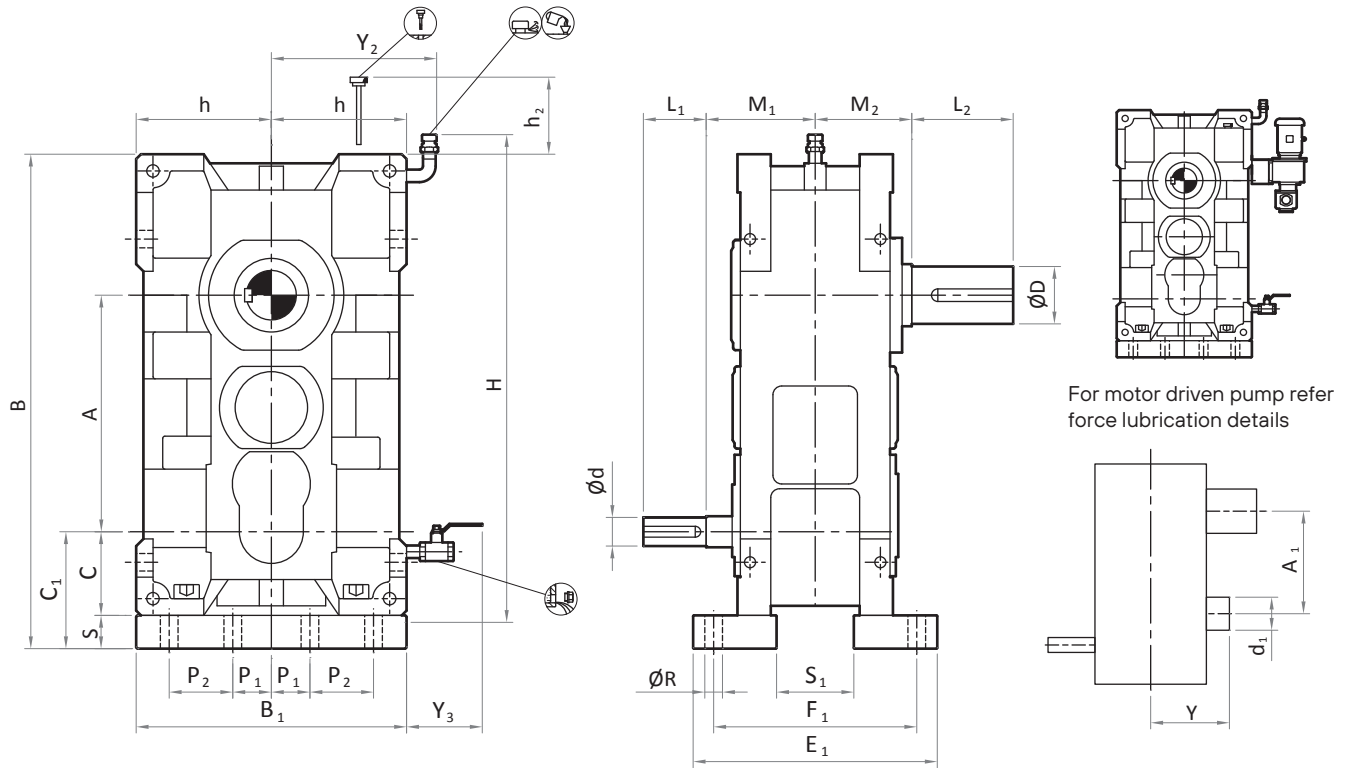

Size	Input Shaft				Mounting Dimensions	Output Shaft			Backstop			Weight (Kg) ¹⁾	Oil Quantity (Liters) ¹⁾	
	i = 20 - 45		i = 50 - 71			M ₁	D	L ₂	M ₂	A ₁	d ₁			Y
	i = 25 - 56		i = 63 - 90											
	d	L ₁	d	L ₁										
720	60	130	42	100	280	140	250	240	453	210	350	1005	71	
721	60	130	42	100	280	160	300	240	502	210	350	1140	71	
722	70	150	45	110	290	170	300	270	556	245	395	1645	128	
723	70	150	45	110	290	180	340	270	617	245	395	1835	128	
724	85	160	60	130	340	200	340	335	647	290	470	2635	237	
725	85	160	60	130	340	210	350	335	712	290	470	2915	239	

Size	Foundation																
	A	B	B ₁	C	C ₁ ^{-0.5}	E ₁	F ₁	h ^{-0.5}	H ¹⁾	h ₂ ¹⁾	P ₁	P ₂	R	S	S ₁	Y ₂ ¹⁾	Y ₃ ¹⁾
720	583	1175	640	207	257	540	470	320	1340	600	120	140	27	50	210	410	230
721	632	1274	640	207	257	540	470	320	1430	600	120	140	27	50	210	410	230
722	716	1415	760	239	299	650	560	380	1580	700	140	180	33	60	245	470	230
723	777	1536	760	239	299	650	560	380	1700	700	140	180	33	60	245	470	230
724	833	1610	880	252	322	760	660	440	1770	700	170	200	39	70	300	530	230
725	898	1740	880	252	322	760	660	440	1900	700	170	200	39	70	300	530	230

1) Approximate values

Helical gear units

4.11 Type H3 – Gear unit shaft arrangement views

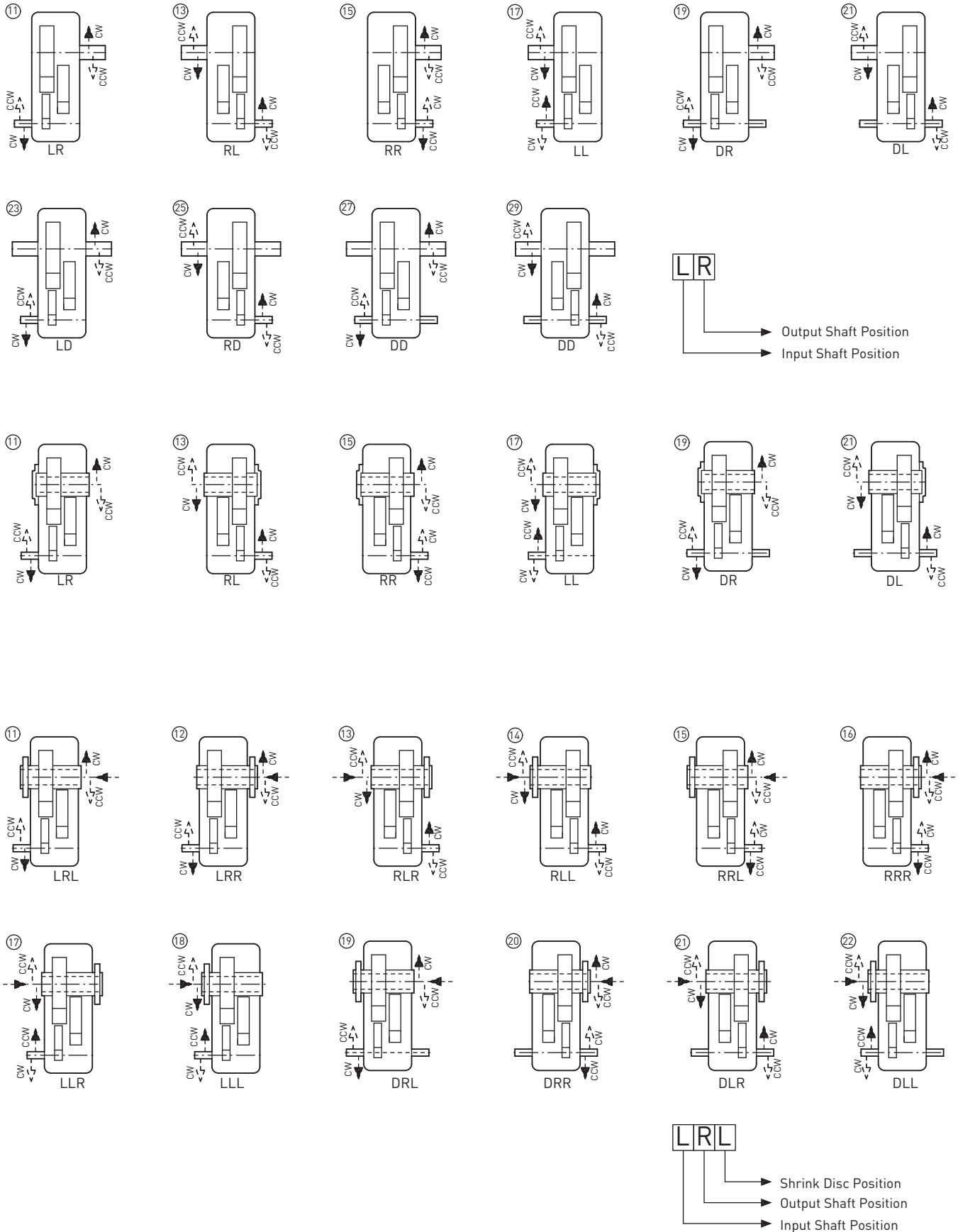

Holdback

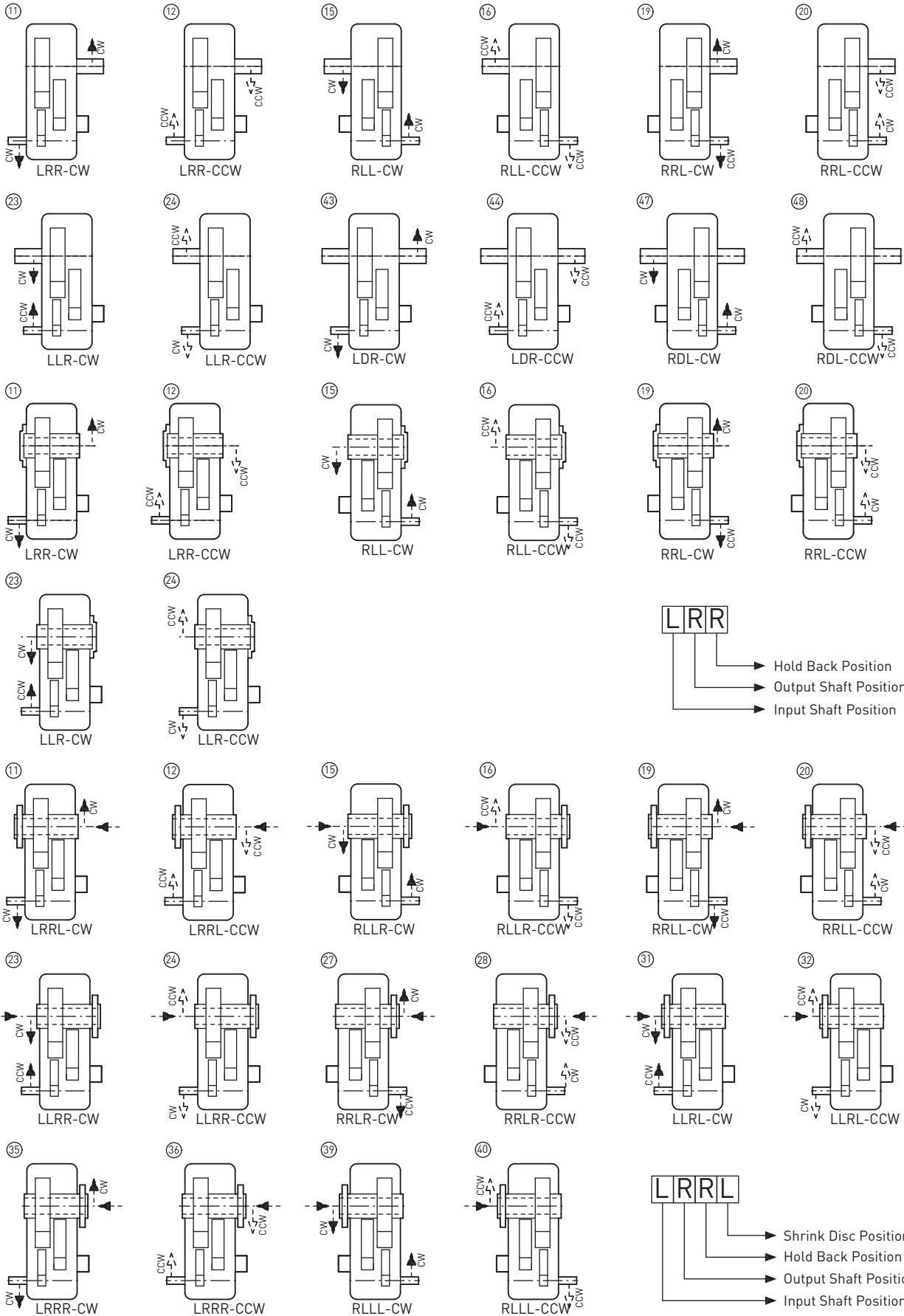

Helical gear units horizontal mounting position

4.12 Type H4H - Gear unit dimensions, Four stage, Size 716 to 719

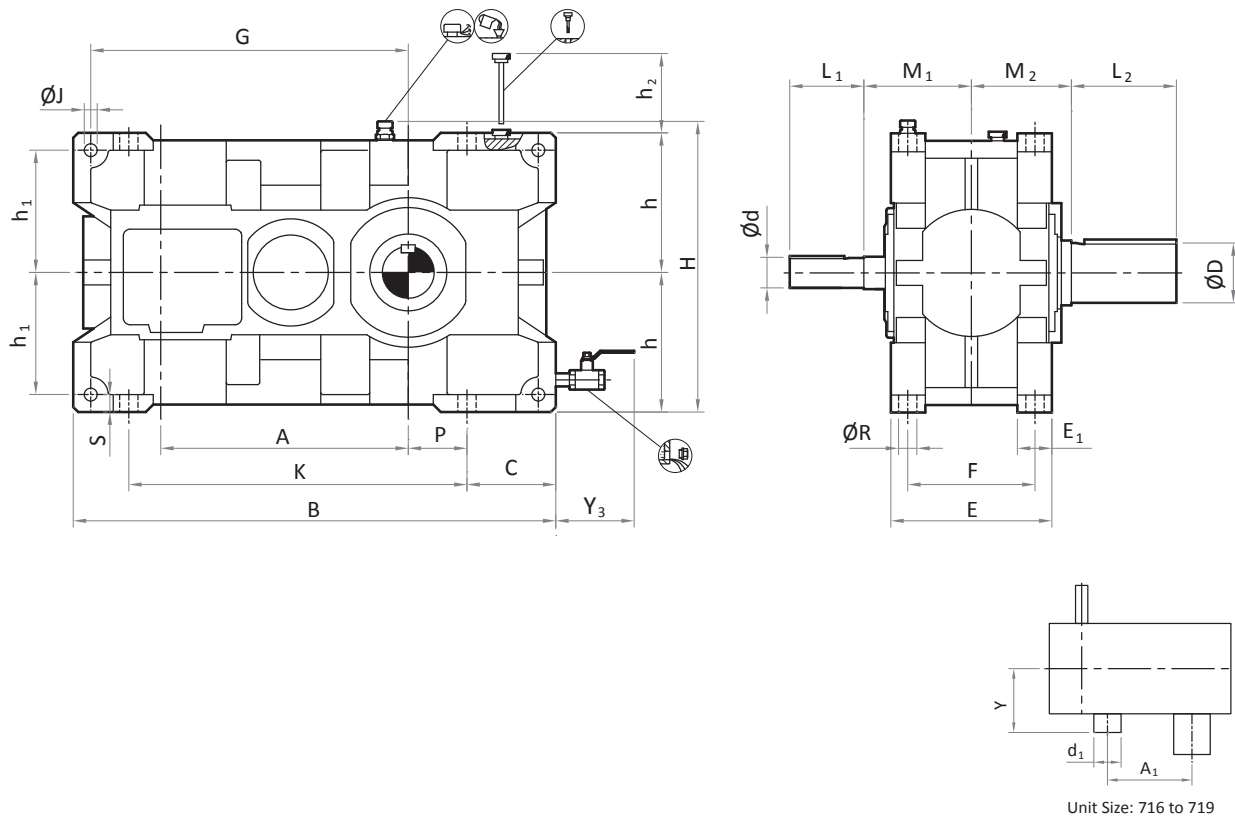

Size	Input Shaft						Mounting Dimensions	Output Shaft			Backstop			Weight (Kg) ¹⁾	Oil Quantity (Liters) ¹⁾	
	i = 80 - 180		i = 200 - 280		i = 315 - 355			M ₁	D	L ₂	M ₂	A ₁	d ₁			Y
	d	L ₁	d	L ₁	d	L ₁										
716	22	60	22	60	18	60	178	100	210	170	377	95	220	355	16	
717	22	60	22	60	18	60	178	110	210	170	414	95	220	400	17	
718	30	75	28	75	22	70	200	120	210	200	466	132	255	570	25	
719	30	75	28	75	22	70	200	130	240	200	515	132	255	655	27	

Size	Foundation																
	A	B	C	E	E ₁	F	G	h ^{-0.5}	h ₁	H ¹⁾	h ₂ ¹⁾	J	K	P	R	S	Y ₃ ¹⁾
716	405	805	145	270	55	224	530	230	200	510	405	23	560	100	18	28	180
717	442	882	145	270	55	224	567	230	200	510	405	23	640	140	18	28	180
718	495	965	165	322	69	270	635	280	245	610	415	27	695	130	23	35	180
719	544	1064	165	322	69	270	684	280	245	610	415	27	795	180	23	35	180

1) Approximate values

Helical gear units horizontal mounting position

4.12 Type H4H - Gear unit dimensions, Four stage, Size 720 to 725

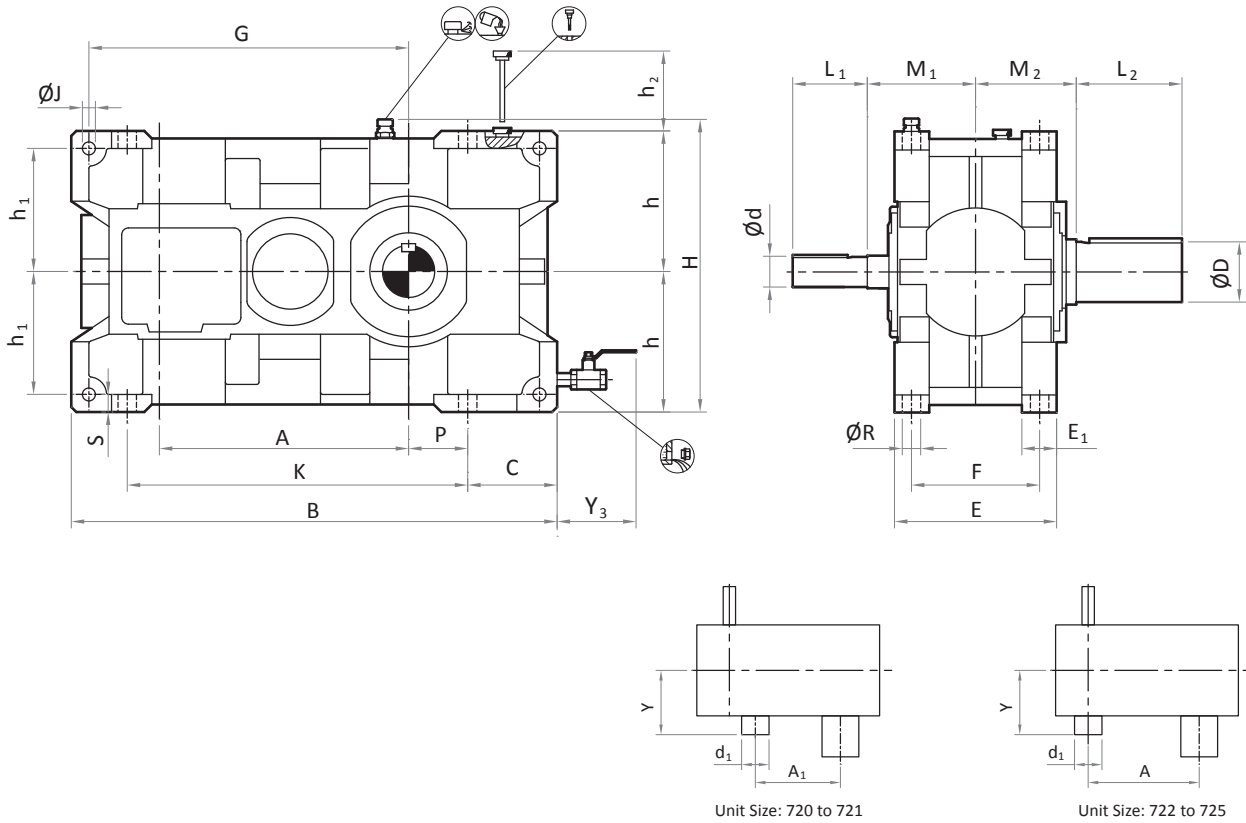

Size	Input Shaft						Mounting Dimensions	Output Shaft			Backstop			Weight (Kg) ¹⁾	Oil Quantity (Liters) ¹⁾	
	i = 80 - 180		i = 200 - 280		i = 315 - 355			M ₁	D	L ₂	M ₂	A ₁	d ₁			Y
	d	L ₁	d	L ₁	d	L ₁										
720	42	100	32	90	28	85	245	140	250	240	552	140	315	925	49	
721	42	100	32	90	28	85	245	160	300	240	601	140	315	1080	52	
722	42	90	32	80	28	75	265	170	300	270	-	140	340	1535	82	
723	42	90	32	80	28	75	265	180	340	270	-	140	340	1710	84	
724	60	130	45	110	38	90	335	200	340	335	-	175	415	2435	129	
725	60	130	45	110	38	90	335	210	350	335	-	175	415	2780	139	

Size	Foundation																
	A	B	C	E	E ₁	F	G	h ^{-0.5}	h ₁	H ¹⁾	h ₂ ¹⁾	J	K	P	R	S	Y ₃ ¹⁾
720	583	1125	175	400	80	340	750	320	280	690	500	33	830	160	27	40	250
721	632	1224	175	400	80	340	799	320	280	690	500	33	930	210	27	40	250
722	716	1355	210	474	100	400	915	380	330	810	650	39	1000	190	33	50	225
723	777	1476	210	474	100	400	976	380	330	810	650	39	1120	250	33	50	225
724	833	1540	220	560	110	475	1035	440	380	930	700	45	1165	235	39	60	225
725	898	1670	220	560	110	475	1100	440	380	930	700	45	1290	300	39	60	225

1) Approximate values

Helical gear units vertical mounting position

4.13 Type H4V - Gear unit dimensions, Four stage, Size 716 to 719

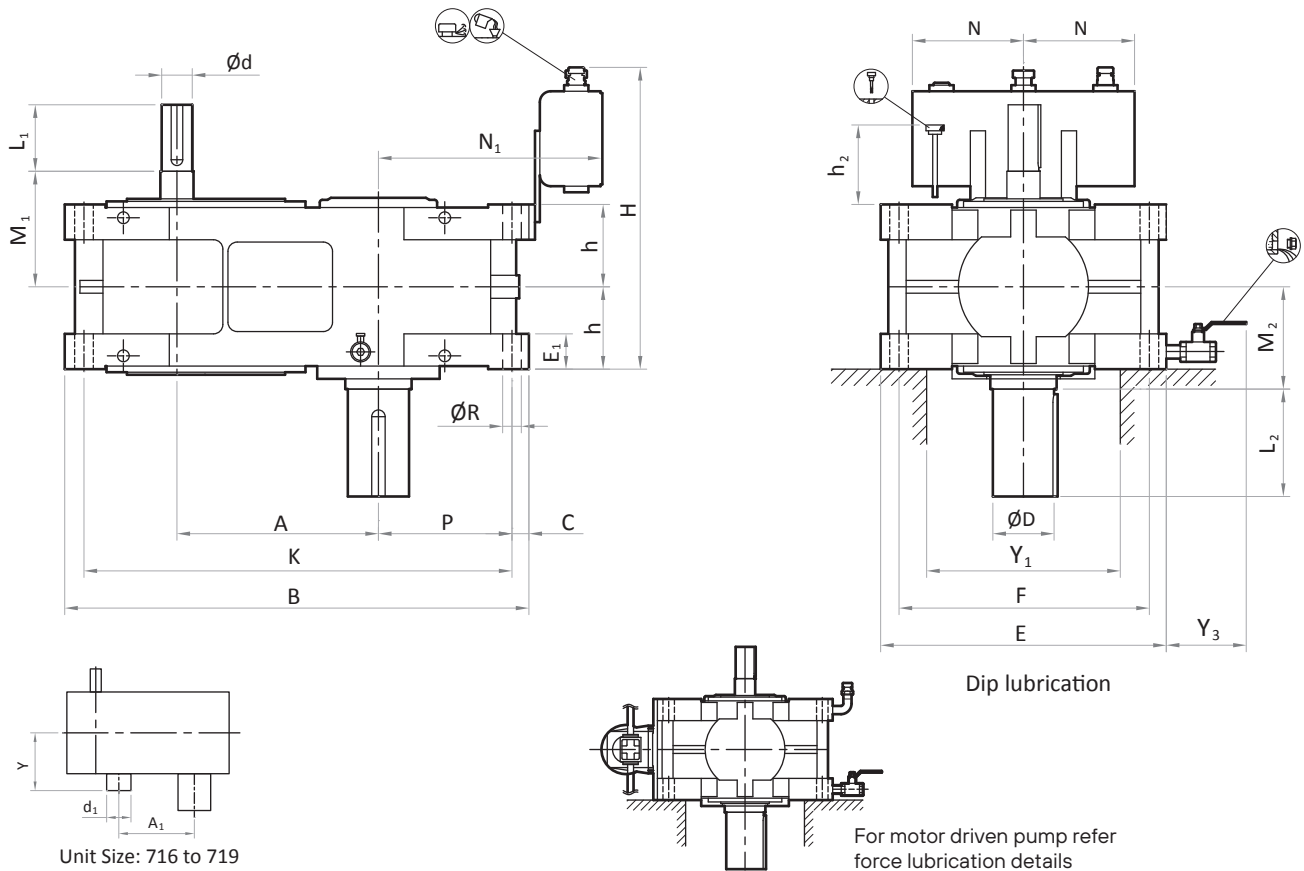

Unit Size: 716 to 719

Dip lubrication

For motor driven pump refer force lubrication details

Size	Input Shaft						Mounting Dimensions	Output Shaft			Backstop			Weight (Kg) ¹⁾	Oil Quantity (Liters) ¹⁾
	i = 80 - 180		i = 200 - 280		i = 315 - 355			D	L ₂	M ₂	A ₁	d ₁	Y		
	d	L ₁	d	L ₁	d	L ₁									
716	22	60	22	60	18	60	178	100	210	170	377	95	220	355	33
717	22	60	22	60	18	60	178	110	210	170	414	95	220	400	35
718	30	75	28	75	22	70	200	120	210	200	466	132	255	570	52
719	30	75	28	75	22	70	200	130	240	200	515	132	255	655	55

Size	Foundation															
	A	B	C	E	E ₁	F	h ^{-0.5}	H ¹⁾	h ₂ ¹⁾	K	N	P	R	Y ₁ ¹⁾	Y ₃ ¹⁾	N ₁
716	405	805	30	460	55	400	135	500	200	745	190	215	23	280	180	395
717	442	882	30	460	55	400	135	500	200	822	190	255	23	280	180	435
718	495	965	35	560	69	490	161	550	240	895	190	260	27	350	180	445
719	544	1064	35	560	69	490	161	550	240	994	190	310	27	350	180	495

1) Approximate values

Helical gear units vertical mounting position

4.13 Type H4V - Gear unit dimensions, Four stage, Size 720 to 725

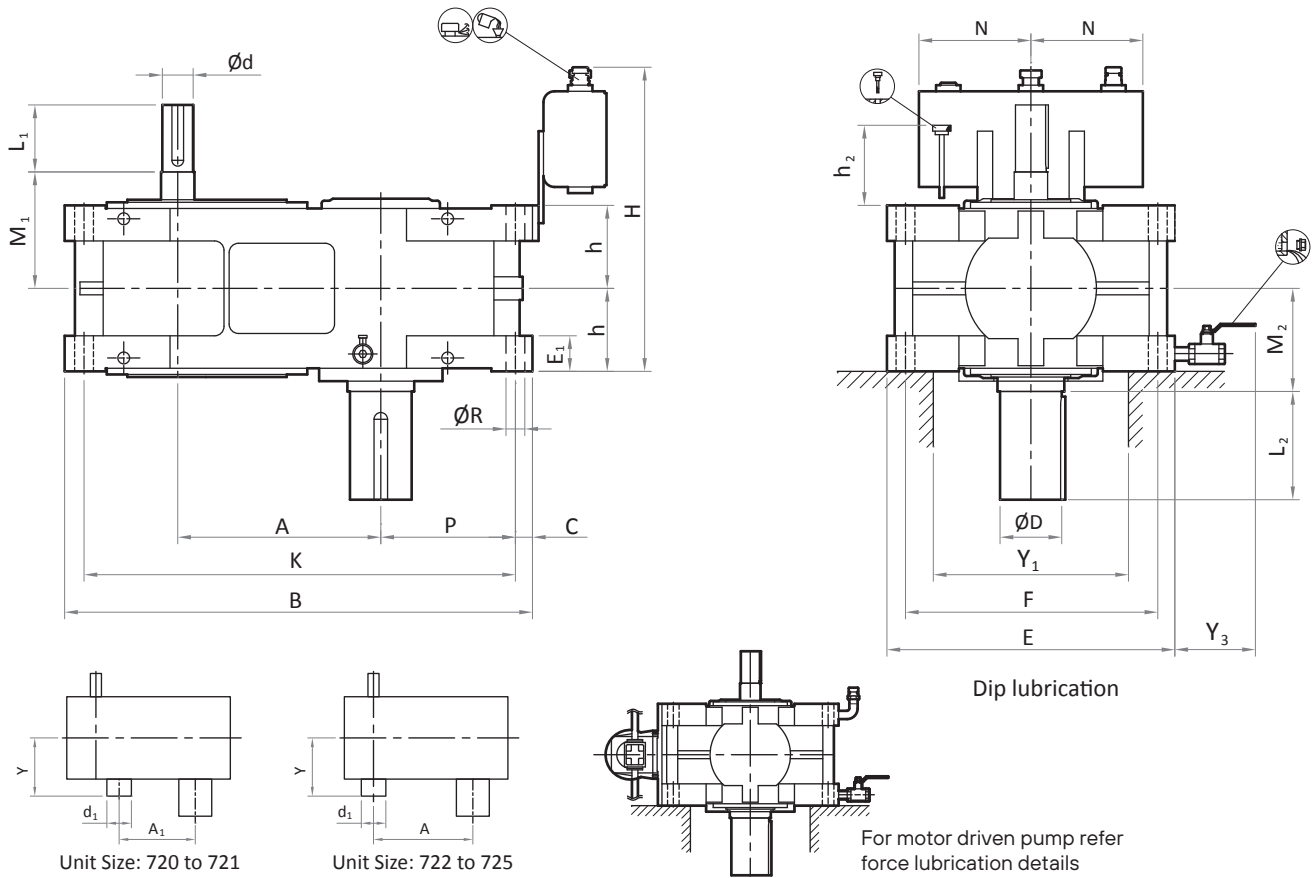

Unit Size: 720 to 721

Unit Size: 722 to 725

Size	Input Shaft						Mounting Dimensions	Output Shaft			Backstop			Weight (Kg) ¹⁾	Oil Quantity (Liters) ¹⁾
	i = 80 - 180		i = 200 - 280		i = 315 - 355			D	L ₂	M ₂	A ₁	d ₁	Y		
	d	L ₁	d	L ₁	d	L ₁									
720	42	100	32	90	28	85	245	140	250	240	552	140	315	925	102
721	42	100	32	90	28	85	245	160	300	240	601	140	315	1080	108
722	42	90	32	80	28	75	265	170	300	270	-	140	340	1535	170
723	42	90	32	80	28	75	265	180	340	270	-	140	340	1710	174
724	60	130	45	110	38	90	335	200	340	335	-	175	415	2435	268
725	60	130	45	110	38	90	335	210	350	335	-	175	415	2780	288

Size	Foundation															
	A	B	C	E	E ₁	F	h ^{-0.5}	H ¹⁾	h ₂ ¹⁾	K	N	P	R	Y ₁ ¹⁾	Y ₃ ¹⁾	N ₁
720	583	1125	40	640	80	560	200	750	300	1045	300	295	33	420	230	535
721	632	1224	40	640	80	560	200	750	300	1144	300	345	33	420	230	585
722	716	1355	40	760	100	660	237	820	350	1275	300	360	39	530	230	600
723	777	1476	40	760	100	660	237	820	350	1396	300	420	39	530	230	660
724	833	1540	50	880	110	760	280	900	420	1440	300	405	45	610	230	655
725	898	1670	50	880	110	760	280	900	420	1570	300	470	45	610	230	720

1) Approximate values

Helical gear units over driven position

4.14 Type H40 - Gear unit dimensions, Four stage, Size 716 to 719

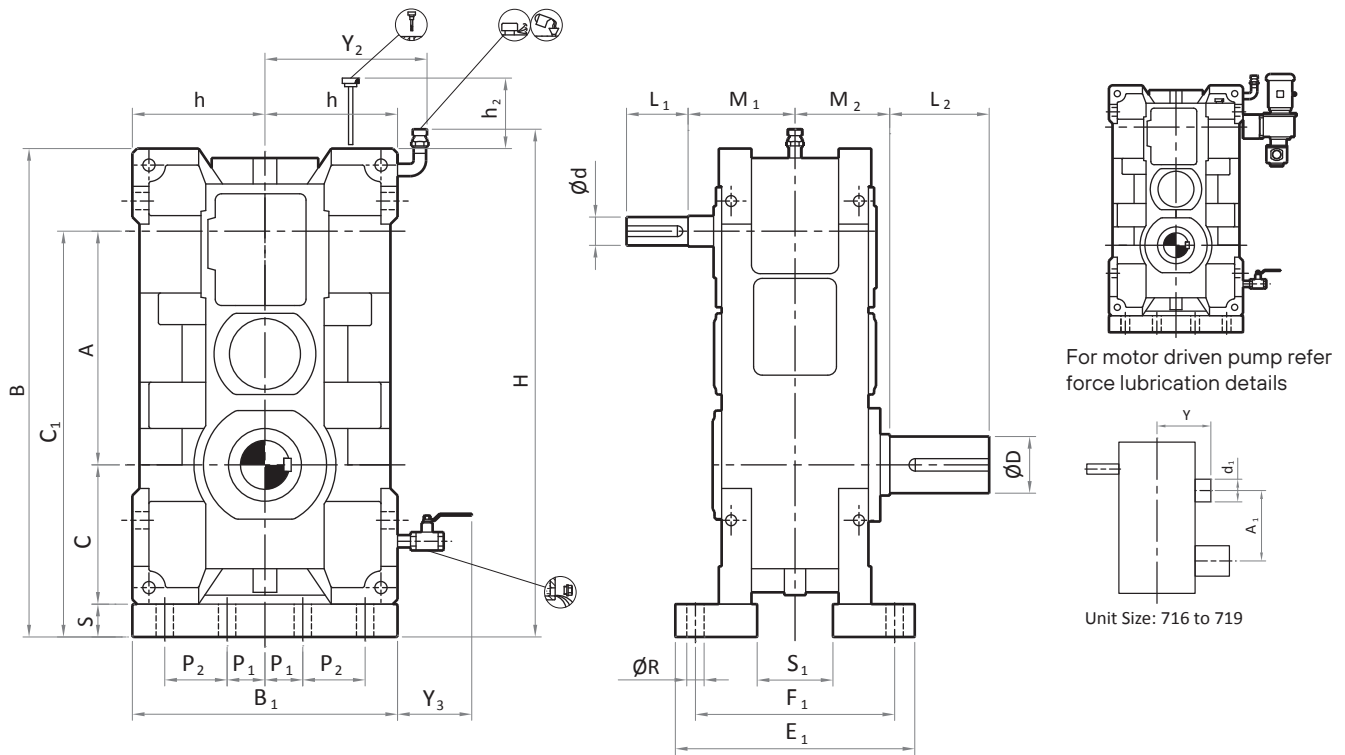

Size	Input Shaft						Mounting Dimensions	Output Shaft				Backstop			Weight (Kg) ¹⁾	Oil Quantity (Liters) ¹⁾
	i = 80 - 180		i = 200 - 280		i = 315 - 355			M ₁	D	L ₂	M ₂	A ₁	d ₁	Y		
	d	L ₁	d	L ₁	d	L ₁										
716	22	60	22	60	18	60	178	100	210	170	377	95	220	380	23	
717	22	60	22	60	18	60	178	110	210	170	414	95	220	425	24	
718	30	75	28	75	22	70	200	120	210	200	466	132	255	620	36	
719	30	75	28	75	22	70	200	130	240	200	515	132	255	705	38	

Size	Foundation																
	A	B	B ₁	C	C ₁ ^{-0.5}	E ₁	F ₁	h ^{-0.5}	H ¹⁾	h ₂ ¹⁾	P ₁	P ₂	R	S	S ₁	Y ₂ ¹⁾	Y ₃ ¹⁾
716	405	835	460	245	680	390	335	230	950	400	90	90	18	30	150	315	180
717	442	912	460	285	757	390	335	230	1025	400	90	90	18	30	150	315	180
718	495	1005	560	295	830	470	410	280	1125	450	100	120	23	40	175	370	180
719	544	1104	560	345	929	470	410	280	1220	450	100	120	23	40	175	370	180

1) Approximate values

Helical gear units over driven position

4.14 Type H40 - Gear unit dimensions, Four stage, Size 720 to 725

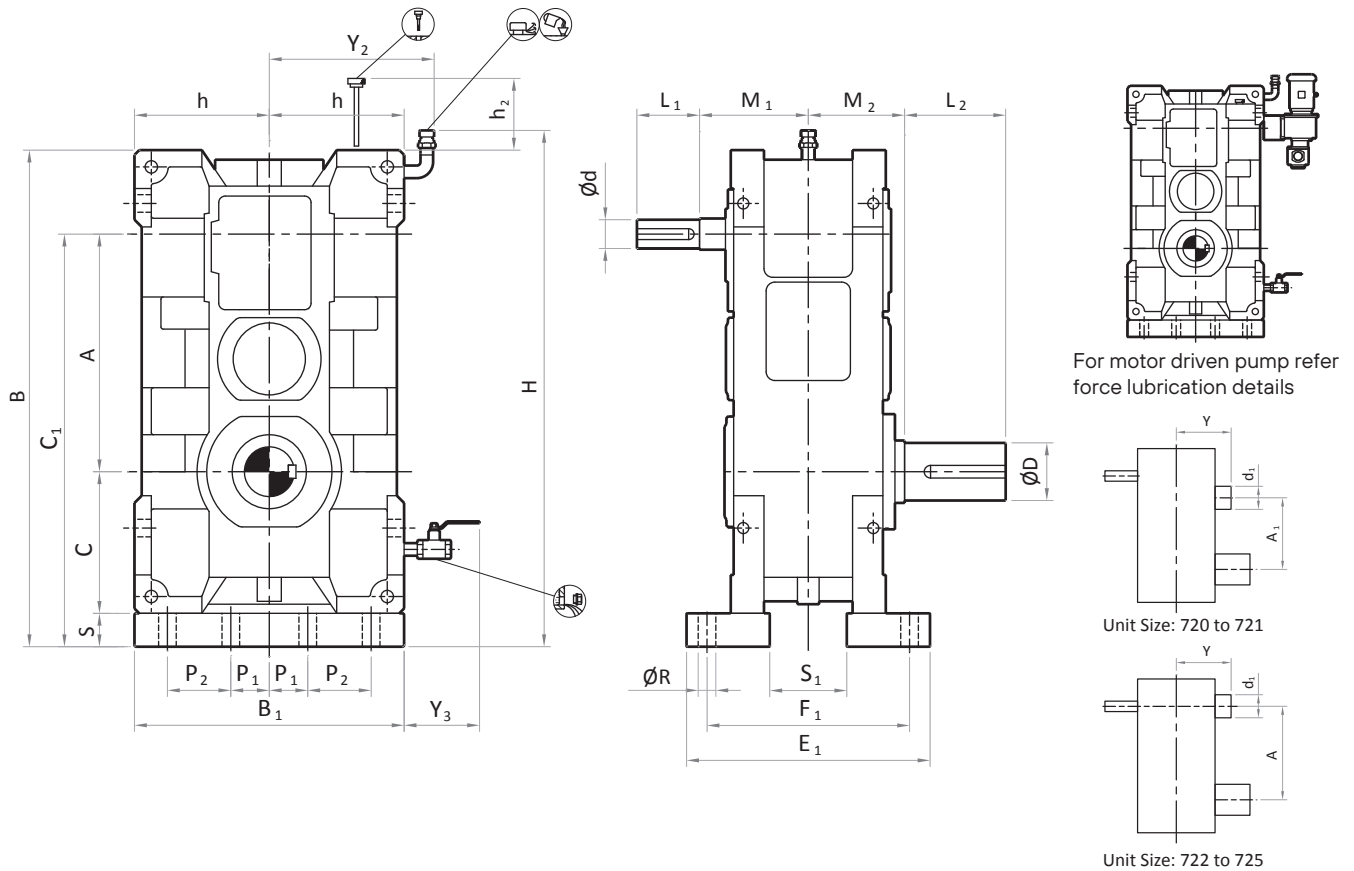

Size	Input Shaft						Mounting Dimensions	Output Shaft				Backstop			Weight (Kg) ¹⁾	Oil Quantity (Liters) ¹⁾
	i = 80 - 180		i = 200 - 280		i = 315 - 355			M ₁	D	L ₂	M ₂	A ₁	d ₁	Y		
	d	L ₁	d	L ₁	d	L ₁										
720	42	100	32	90	28	85	245	140	250	240	552	140	315	1005	71	
721	42	100	32	90	28	85	245	160	300	240	601	140	315	1160	75	
722	42	90	32	80	28	75	265	170	300	270	-	140	340	1675	118	
723	42	90	32	80	28	75	265	180	340	270	-	140	340	1850	121	
724	60	130	45	110	38	90	335	200	340	335	-	175	415	2650	186	
725	60	130	45	110	38	90	335	210	350	335	-	175	415	2995	200	

Size	Foundation																
	A	B	B ₁	C	C ₁ ^{-0.5}	E ₁	F ₁	h ^{-0.5}	H ¹⁾	h ₂ ¹⁾	P ₁	P ₂	R	S	S ₁	Y ₂ ¹⁾	Y ₃ ¹⁾
720	583	1175	640	335	968	540	470	320	1340	600	120	140	27	50	210	410	230
721	632	1274	640	385	1067	540	470	320	1430	600	120	140	27	50	210	410	230
722	716	1415	760	400	1176	650	560	380	1580	700	140	180	33	60	245	470	230
723	777	1536	760	460	1297	650	560	380	1700	700	140	180	33	60	245	470	230
724	833	1610	880	455	1358	760	660	440	1770	700	170	200	39	70	300	530	230
725	898	1740	880	520	1488	760	660	440	1900	700	170	200	39	70	300	530	230

1) Approximate values

Helical gear units under driven position

4.15 Type H4U - Gear unit dimensions, Four stage, Size 716 to 719

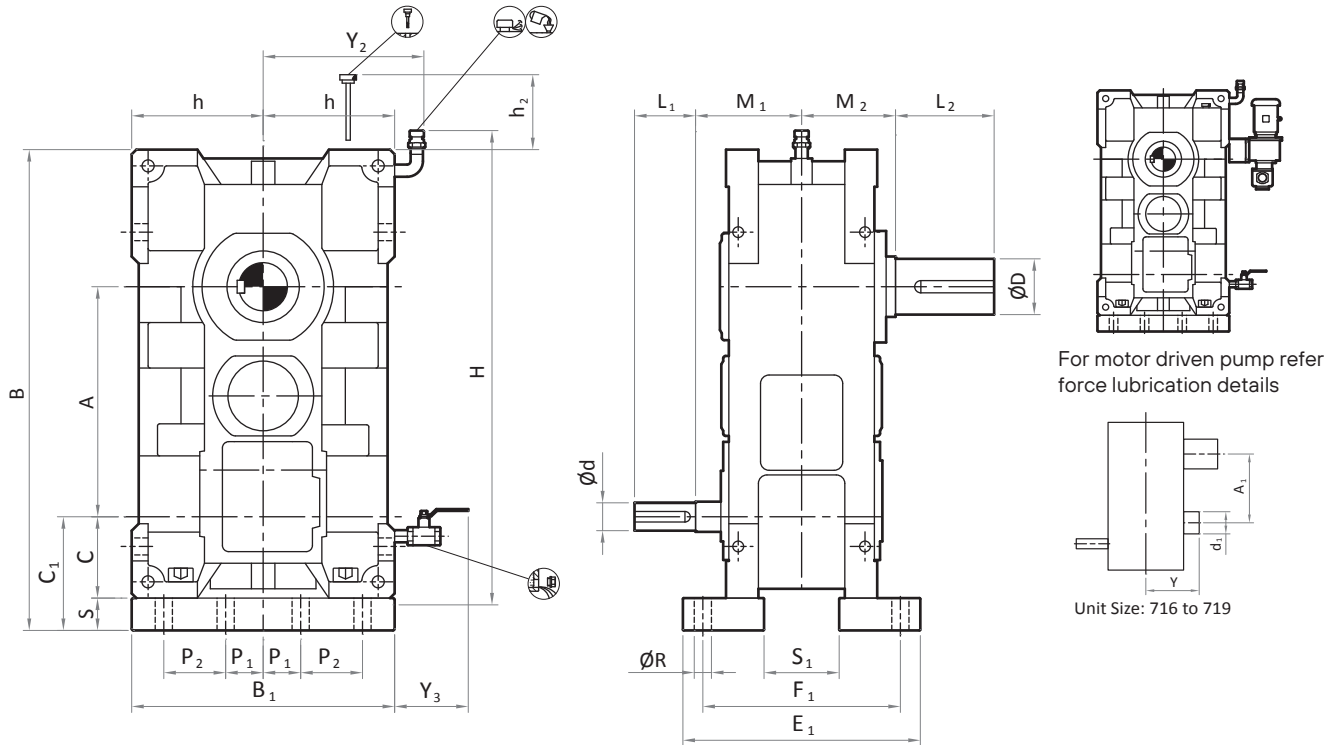

Size	Input Shaft						Mounting Dimensions	Output Shaft			Backstop			Weight (Kg) ¹⁾	Oil Quantity (Liters) ¹⁾	
	i = 80 - 180		i = 200 - 280		i = 315 - 355			M ₁	D	L ₂	M ₂	A ₁	d ₁			Y
	d	L ₁	d	L ₁	d	L ₁										
716	22	60	22	60	18	60	178	100	210	170	377	95	220	380	23	
717	22	60	22	60	18	60	178	110	210	170	414	95	220	425	24	
718	30	75	28	75	22	70	200	120	210	200	466	132	255	620	36	
719	30	75	28	75	22	70	200	130	240	200	515	132	255	705	38	

Size	Foundation																
	A	B	B ₁	C	C ₁ ^{-0.5}	E ₁	F ₁	h ^{-0.5}	H ¹⁾	h ₂ ¹⁾	P ₁	P ₂	R	S	S ₁	Y ₂ ¹⁾	Y ₃ ¹⁾
716	405	835	460	155	185	390	335	230	950	400	90	90	18	30	150	315	180
717	442	912	460	155	185	390	335	230	1025	400	90	90	18	30	150	315	180
718	495	1005	560	175	215	470	410	280	1125	450	100	120	23	40	175	370	180
719	544	1104	560	175	215	470	410	280	1220	450	100	120	23	40	175	370	180

1) Approximate values

Helical gear units under driven position

4.15 Type H4U - Gear unit dimensions, Four stage, Size 720 to 725

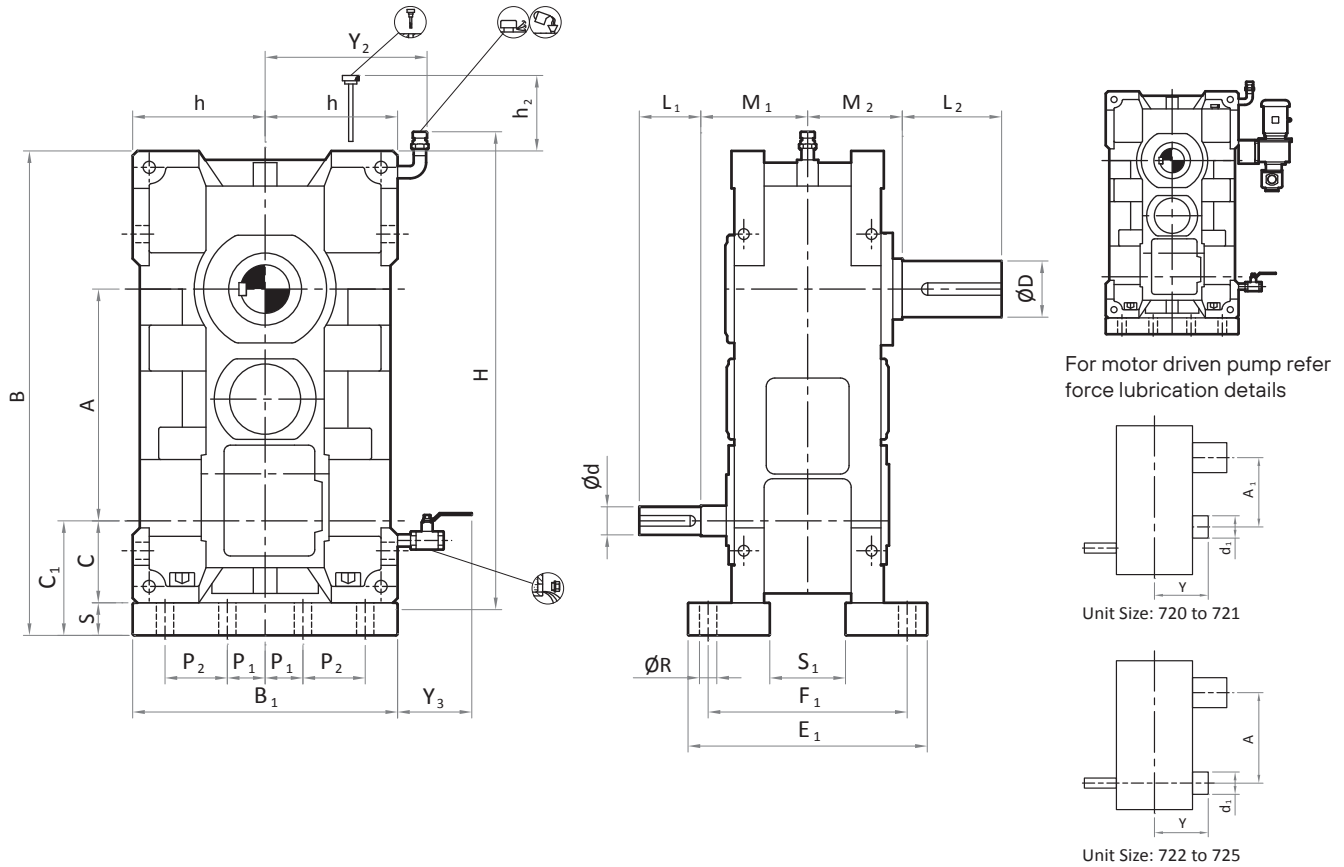

Size	Input Shaft						Mounting Dimensions	Output Shaft				Backstop			Weight (Kg) ¹⁾	Oil Quantity (Liters) ¹⁾
	i = 80 - 180		i = 200 - 280		i = 315 - 355			M ₁	D	L ₂	M ₂	A ₁	d ₁	Y		
	d	L ₁	d	L ₁	d	L ₁										
720	42	100	32	90	28	85	245	140	250	240	552	140	315	1005	71	
721	42	100	32	90	28	85	245	160	300	240	601	140	315	1160	75	
722	42	90	32	80	28	75	265	170	300	270	-	140	340	1675	118	
723	42	90	32	80	28	75	265	180	340	270	-	140	340	1850	121	
724	60	130	45	110	38	90	335	200	340	335	-	175	415	2650	186	
725	60	130	45	110	38	90	335	210	350	335	-	175	415	2995	200	

Size	Foundation																
	A	B	B ₁	C	C ₁ ^{-0.5}	E ₁	F ₁	h ^{-0.5}	H ¹⁾	h ₂ ¹⁾	P ₁	P ₂	R	S	S ₁	Y ₂ ¹⁾	Y ₃ ¹⁾
720	583	1175	640	207	257	540	470	320	1340	600	120	140	27	50	210	410	230
721	632	1274	640	207	257	540	470	320	1430	600	120	140	27	50	210	410	230
722	716	1415	760	239	299	650	560	380	1580	700	140	180	33	60	245	470	230
723	777	1536	760	239	299	650	560	380	1700	700	140	180	33	60	245	470	230
724	833	1610	880	252	322	760	660	440	1770	700	170	200	39	70	300	530	230
725	898	1740	880	252	322	760	660	440	1900	700	170	200	39	70	300	530	230

1) Approximate values

Helical gear units over driven position

4.16 Type H4 - Gear unit shaft arrangement views

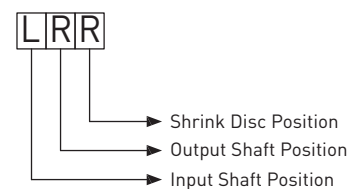
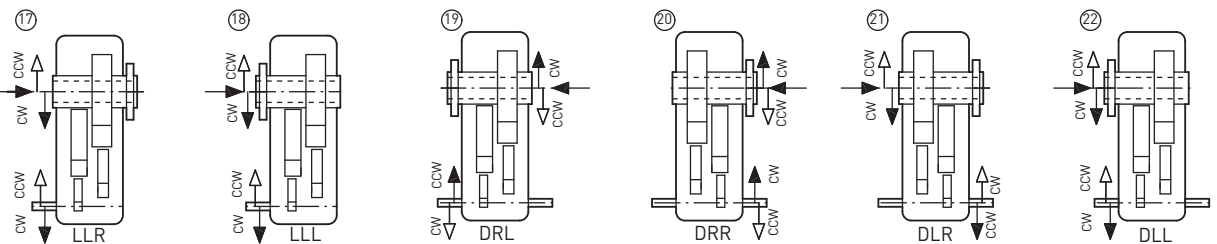
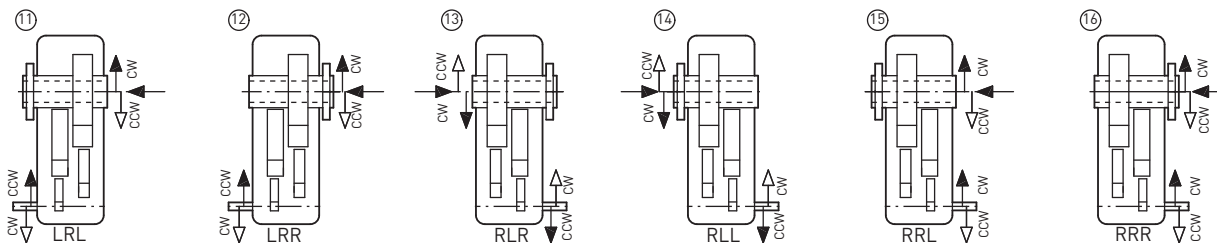
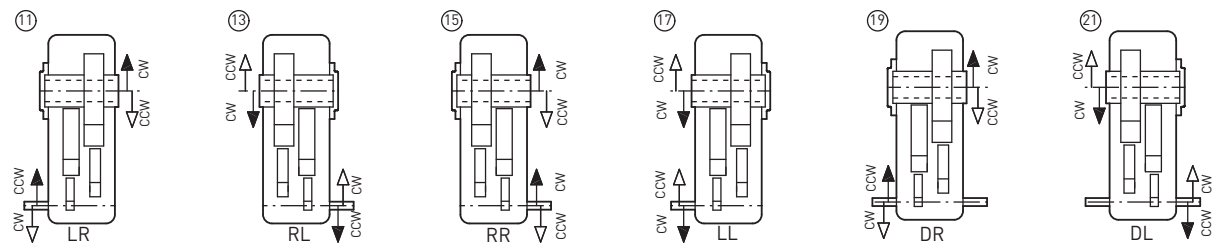
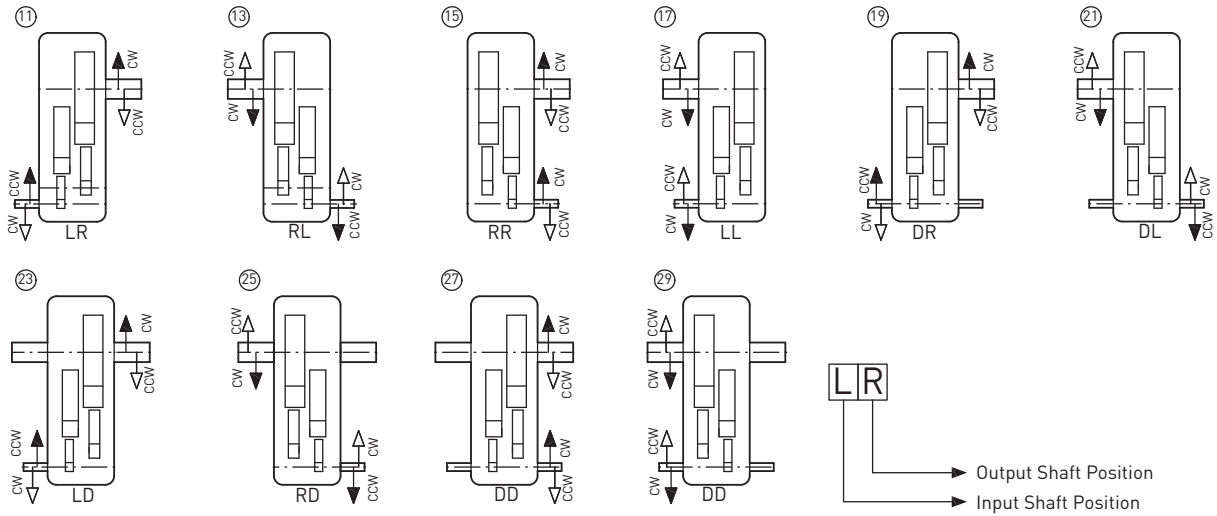

Holdback

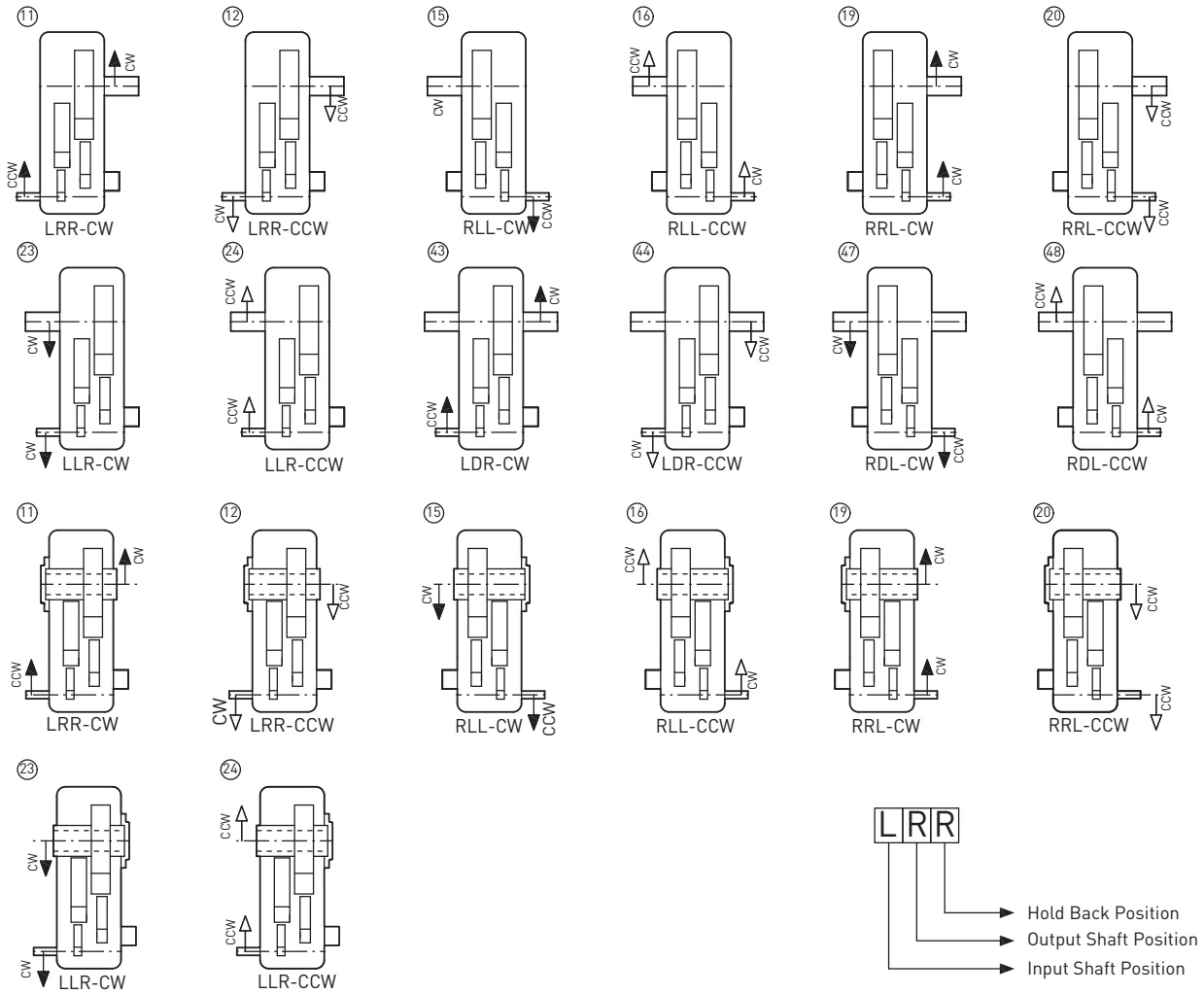

Holdback

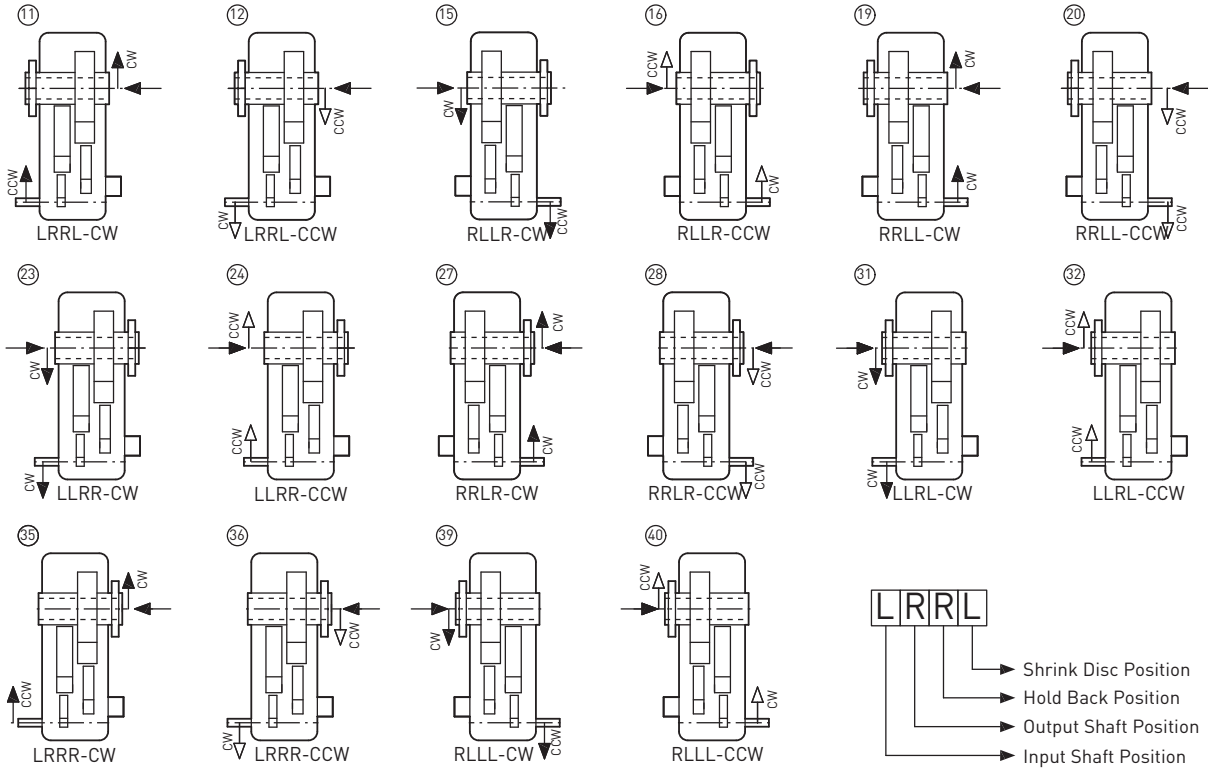



BEVEL HELICAL GEAR UNITS

- 5.1 Type B2H – Gear unit dimensions
- 5.2 Type B2V – Gear unit dimensions
- 5.3 Type B2O – Gear unit dimensions
- 5.4 Type B2 – Gear unit shaft arrangement views
- 5.5 Type B3H – Gear unit dimensions
- 5.6 Type B3V – Gear unit dimensions
- 5.7 Type B3O – Gear unit dimensions
- 5.8 Type B3 – Gear unit shaft arrangement views
- 5.9 Type B4H – Gear unit dimensions
- 5.10 Type B4V – Gear unit dimensions
- 5.11 Type B4O – Gear unit dimensions
- 5.12 Type B4 – Gear unit shaft arrangement views

Bevel Helical gear units horizontal mounting position

5.1 Type B2H - Gear unit dimensions, Two stage, Size 712 to 719

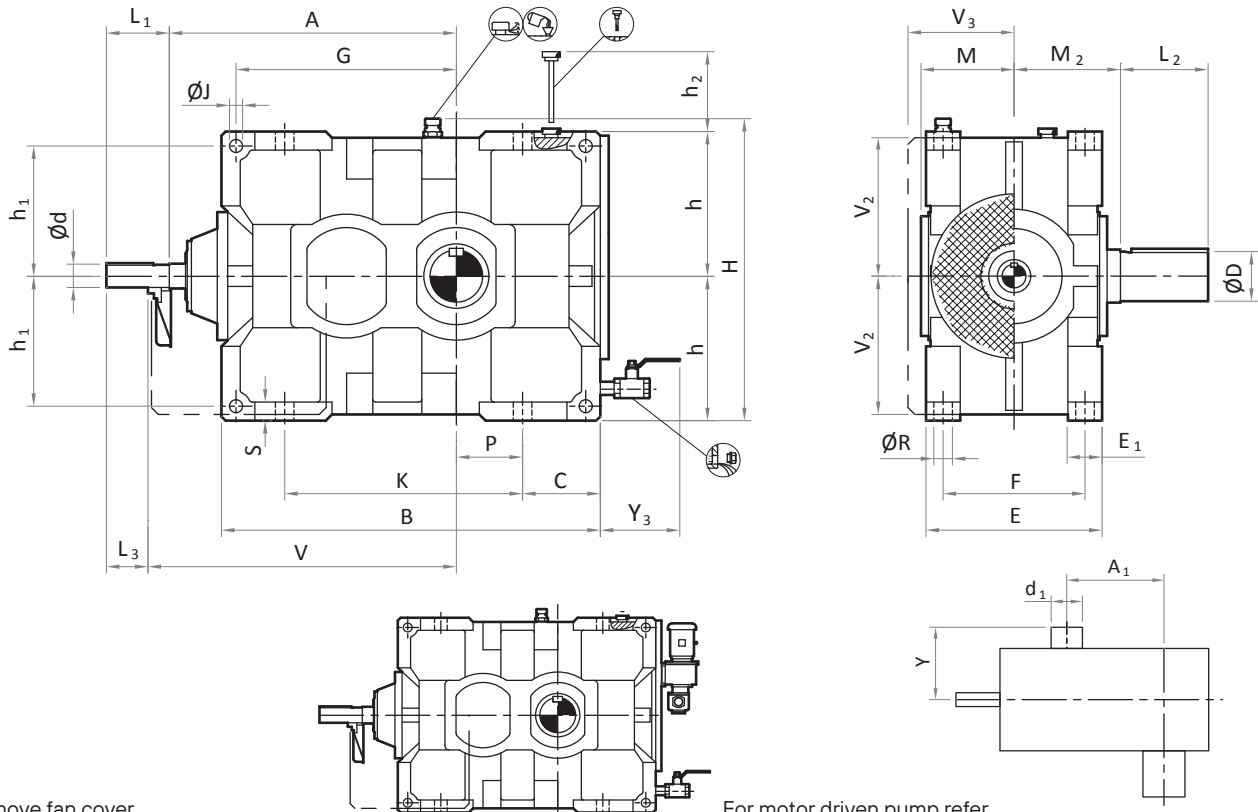

* Remove fan cover before installation

For motor driven pump refer force lubrication details

Size	Input Shaft						Mounting Dimension			Output Shaft				Backstop			Weight (Kg) ¹⁾	Oil Quantity (Liters) ¹⁾
	i = 5 - 12.5			i = 14 - 18														
	i = 5 - 14			i = 16 - 20														
	i = 5.6 - 16			i = 18 - 22.4														
d	L ₁	L ₃	d	L ₁	L ₃	V	V ₂ ¹⁾	V ₃ ¹⁾	D	L ₂	M ₂	M	A ₁	d ₁	Y			
712	28	85	55	20	80	50	335	145	140	45	90	155	125	90	95	185	80	4
713	30	85	55	30	85	55	365	145	140	45	90	155	125	100	105	190	90	6
714	35	90	60	32	90	60	430	195	180	60	120	195	170	130	150	255	175	8
715	45	110	80	35	90	60	515	195	180	80	160	210	170	160	175	275	225	9
716	55	120	90	45	110	80	566	285	205	90	160	220	200	186	210	320	375	16
717	55	120	90	45	110	80	585	285	205	110	210	220	200	205	210	320	420	19
718	70	150	120	55	120	90	687	342	245	120	210	255	235	232	245	375	700	34
719	70	150	120	55	120	90	718	342	245	130	240	255	235	263	245	375	780	37

Size	Foundation																
	A	B	C	E	E ₁	F	G	h ^{-0.5}	h ₁	H ¹⁾	h ₂ ¹⁾	J	K	P	R	S	Y ₃ ¹⁾
712	305	380	75	216	43	180	217	150	132	350	200	14	230	70	14	18	140
713	335	415	75	216	43	180	242	150	132	350	200	14	260	80	14	18	140
714	400	500	100	300	58	250	286	200	176	450	260	23	310	90	18	24	150
715	485	580	100	300	58	250	336	200	176	450	260	23	370	120	18	24	150
716	536	711	145	346	61	295	416	290	260	630	390	23	410	120	18	35	190
717	555	750	145	346	61	295	435	290	260	630	390	23	470	140	18	35	190
718	657	847	165	422	82	355	497	350	315	750	470	27	520	150	27	45	190
719	688	908	165	422	82	355	528	350	315	750	470	27	600	180	27	45	190

1) Approximate values

Bevel Helical gear units horizontal mounting position

5.1 Type B2H - Gear unit dimensions, Two stage, Size 720 to 725

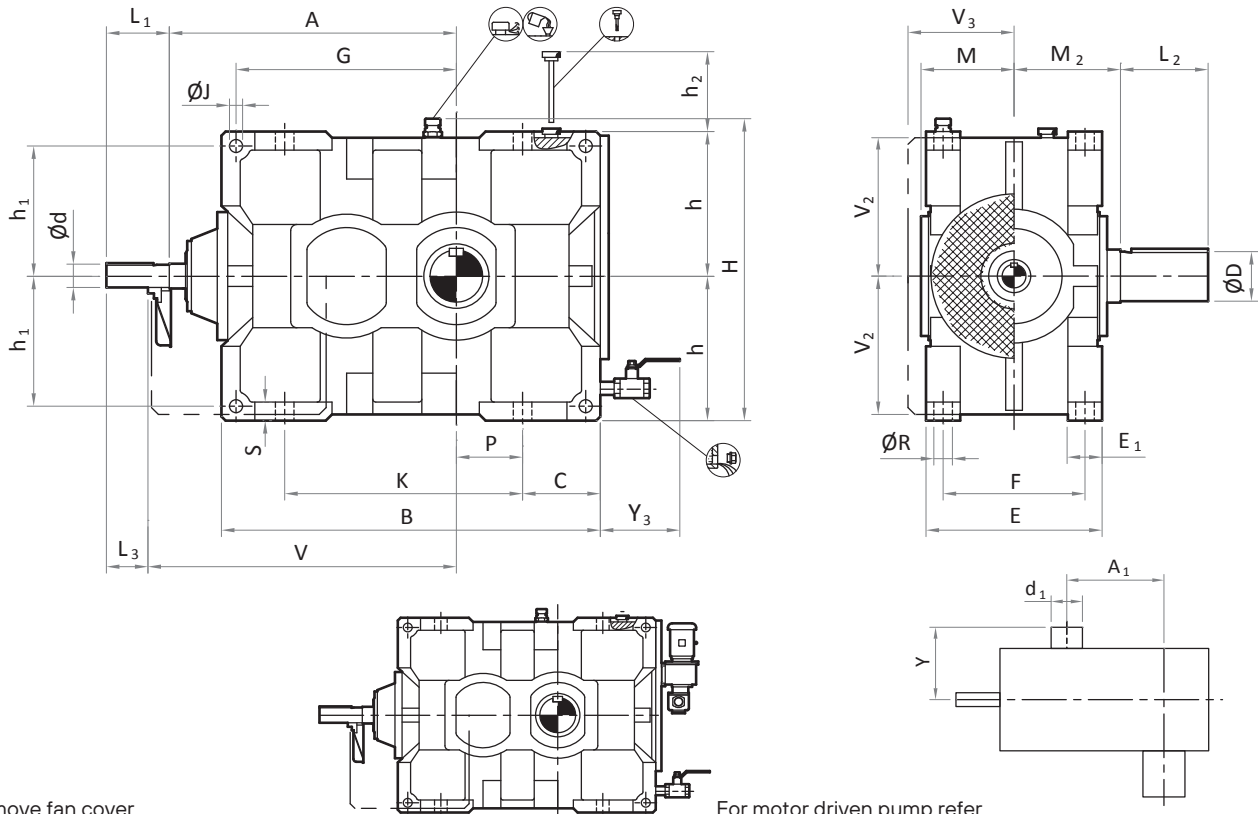

* Remove fan cover before installation

For motor driven pump refer force lubrication details

Size	Input Shaft						Mounting Dimension			Output Shaft				Backstop			Weight (Kg) ¹⁾	Oil Quantity (Liters) ¹⁾
	i = 5 - 12.5			i = 14 - 18														
	i = 5 - 14			i = 16 - 20														
	i = 5.6 - 16			i = 18 - 22.4														
d	L ₁	L ₃	d	L ₁	L ₃	V	V ₂ ¹⁾	V ₃ ¹⁾	D	L ₂	M ₂	M	A ₁	d ₁	Y			
720	80	160	130	60	130	100	790	412	285	135	250	290	275	270	290	430	1070	50
721	80	160	130	60	130	100	810	412	285	160	300	290	275	290	290	430	1180	100
722	90	170	140	70	150	120	963	492	350	170	300	345	330	328	290	475	1865	88
723	90	170	140	70	150	120	1019	492	350	180	340	345	335	384	290	475	1990	97
724	110	190	160	80	160	130	1106	570	370	200	340	390	360	376	400	520	2690	149
725	110	190	160	80	160	130	1175	570	370	210	350	390	360	445	400	520	3035	162

Size	Foundation																
	A	B	C	E	E ₁	F	G	h ^{-0.5}	h ₁	H ¹⁾	h ₂ ¹⁾	J	K	P	R	S	Y ₃ ¹⁾
720	760	955	165	492	98	415	560	420	375	890	560	33	630	190	33	45	245
721	780	995	165	492	98	415	580	420	375	890	560	33	670	210	33	45	245
722	933	1128	210	620	100	545	648	500	445	1050	665	39	750	220	33	55	225
723	989	1244	210	620	100	545	704	500	445	1050	665	39	860	280	33	55	225
724	1076	1336	250	660	110	575	776	580	520	1210	780	45	825	250	39	60	215
725	1145	1475	250	660	110	575	845	580	520	1210	780	45	990	320	39	60	215

1) Approximate values

Bevel Helical gear units vertical mounting position

5.2 Type B2V - Gear unit dimensions, Two stage, Size 712 to 719

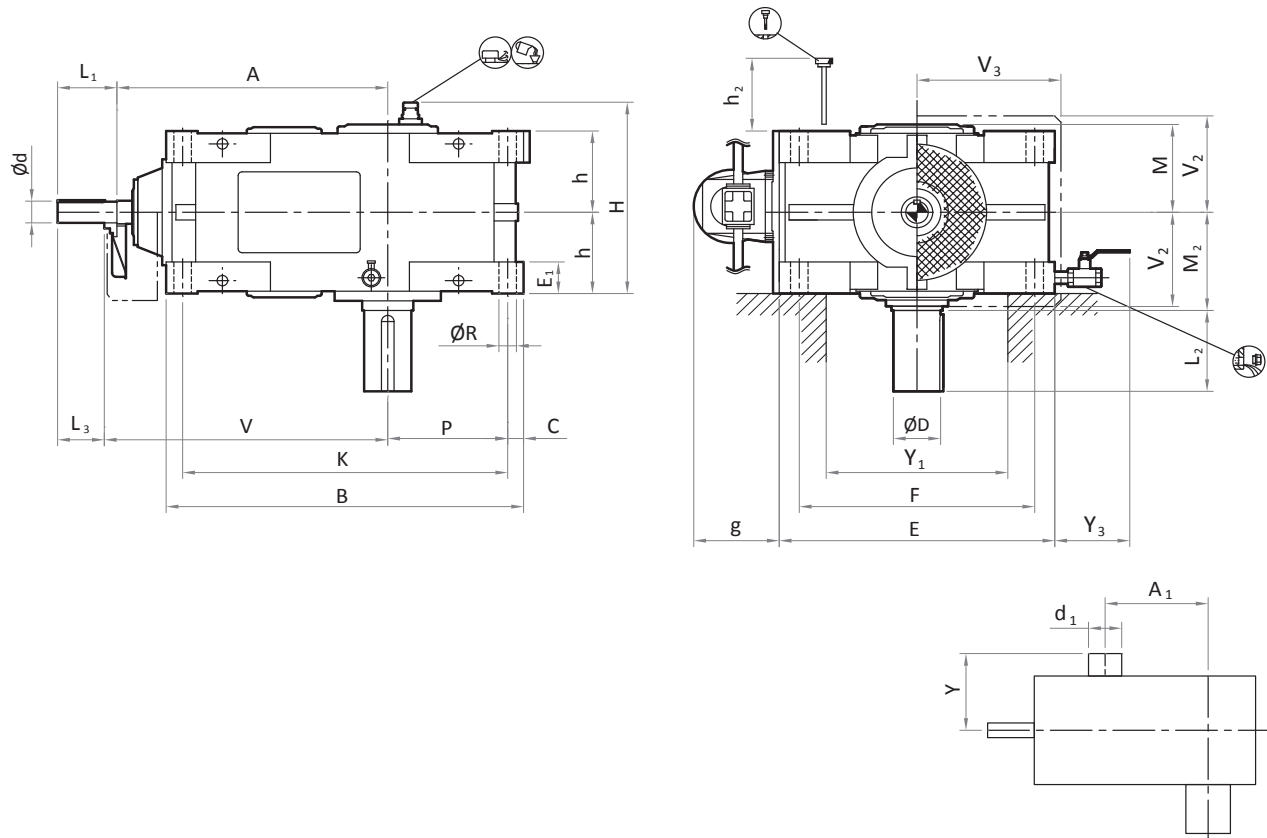

Size	Input Shaft						Mounting Dimension			Output Shaft				Backstop			Weight (Kg) ¹⁾	Oil Quantity (Liters) ¹⁾
	i = 5 - 12.5			i = 14 - 18														
	i = 5 - 14			i = 16 - 20														
	i = 5.6 - 16			i = 18 - 22.4														
d	L ₁	L ₃	d	L ₁	L ₃	V	V ₂ ¹⁾	V ₃ ¹⁾	D	L ₂	M ₂	M	A ₁	d ₁	Y			
712	28	85	55	20	80	50	335	140	180	45	90	155	125	90	95	185	80	5
713	30	85	55	30	85	55	365	140	180	45	90	155	125	100	105	190	90	7
714	35	90	60	32	90	60	430	180	230	60	120	195	170	130	150	255	175	10
715	45	110	80	35	90	60	515	180	230	80	160	210	170	160	175	275	225	11
716	55	120	90	45	110	80	566	205	320	90	160	220	200	186	210	320	375	19
717	55	120	90	45	110	80	585	205	320	110	210	220	200	205	210	320	420	23
718	70	150	120	55	120	90	687	245	385	120	210	255	235	232	245	375	700	41
719	70	150	120	55	120	90	718	245	385	130	240	255	235	263	245	375	780	44

Size	Foundation															
	A	B	C	E	E ₁	F	h ^{-0.5}	H ¹⁾	h ₂ ¹⁾	K	P	R	Y ₁ ¹⁾	Y ₃ ¹⁾	g ¹⁾	
712	305	380	18	300	43	264	108	266	150	344	127	14	200	160	-	
713	335	415	18	300	43	264	108	266	150	379	137	14	200	160	-	
714	400	500	24	400	58	352	150	350	220	452	166	23	300	170	300	
715	485	580	24	400	58	352	150	350	220	532	196	23	300	170	300	
716	536	711	30	580	61	520	173	396	265	651	235	23	370	180	300	
717	555	750	30	580	61	520	173	396	265	690	255	23	370	180	300	
718	657	847	35	700	82	630	211	472	320	777	280	27	470	180	350	
719	688	908	35	700	82	630	211	472	320	838	310	27	470	180	350	

1) Approximate values

Bevel Helical gear units vertical mounting position

5.2 Type B2V - Gear unit dimensions, Two stage, Size 720 to 725

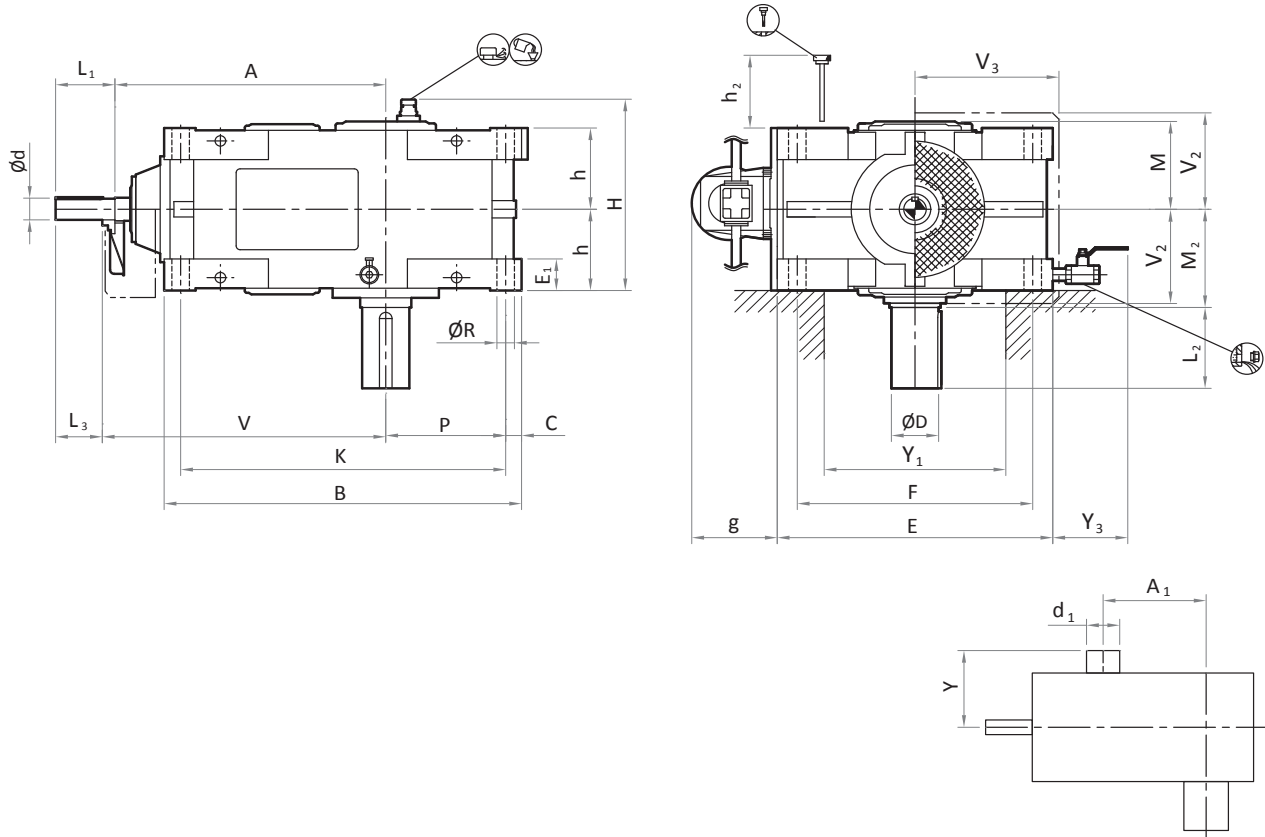

Size	Input Shaft						Mounting Dimension			Output Shaft				Backstop			Weight (Kg) ¹⁾	Oil Quantity (Liters) ¹⁾
	i = 5 - 12.5			i = 14 - 18														
	i = 5 - 14			i = 16 - 20														
	i = 5.6 - 16			i = 18 - 22.4														
d	L ₁	L ₃	d	L ₁	L ₃	V	V ₂ ¹⁾	V ₃ ¹⁾	D	L ₂	M ₂	M	A ₁	d ₁	Y			
720	80	160	130	60	130	100	790	285	455	135	250	290	275	270	290	430	1070	60
721	80	160	130	60	130	100	810	285	455	160	300	290	275	290	290	430	1180	120
722	90	170	140	70	150	120	963	350	535	170	300	345	330	328	290	475	1865	106
723	90	170	140	70	150	120	1019	350	535	180	340	345	335	384	290	475	1990	116
724	110	190	160	80	160	130	1106	370	620	200	340	390	360	376	400	520	2690	179
725	110	190	160	80	160	130	1175	370	620	210	350	390	360	445	400	520	3035	195

Size	Foundation														
	A	B	C	E	E ₁	F	h ^{-0.5}	H ¹⁾	h ₂ ¹⁾	K	P	R	Y ₁ ¹⁾	Y ₃ ¹⁾	g ¹⁾
720	760	955	40	840	98	750	246	542	370	875	315	33	600	220	350
721	780	995	40	840	98	750	246	542	370	915	335	33	600	220	350
722	933	1128	50	1000	100	890	310	670	500	1028	380	39	800	220	350
723	989	1244	50	1000	100	890	310	670	500	1144	440	39	800	220	350
724	1076	1336	60	1160	110	1040	330	710	530	1216	440	45	900	220	350
725	1145	1475	60	1160	110	1040	330	710	530	1355	510	45	900	220	350

1) Approximate values

Bevel Helical gear units over driven mounting position

5.3 Type B2O - Gear unit dimensions, Two stage, Size 712 to 719

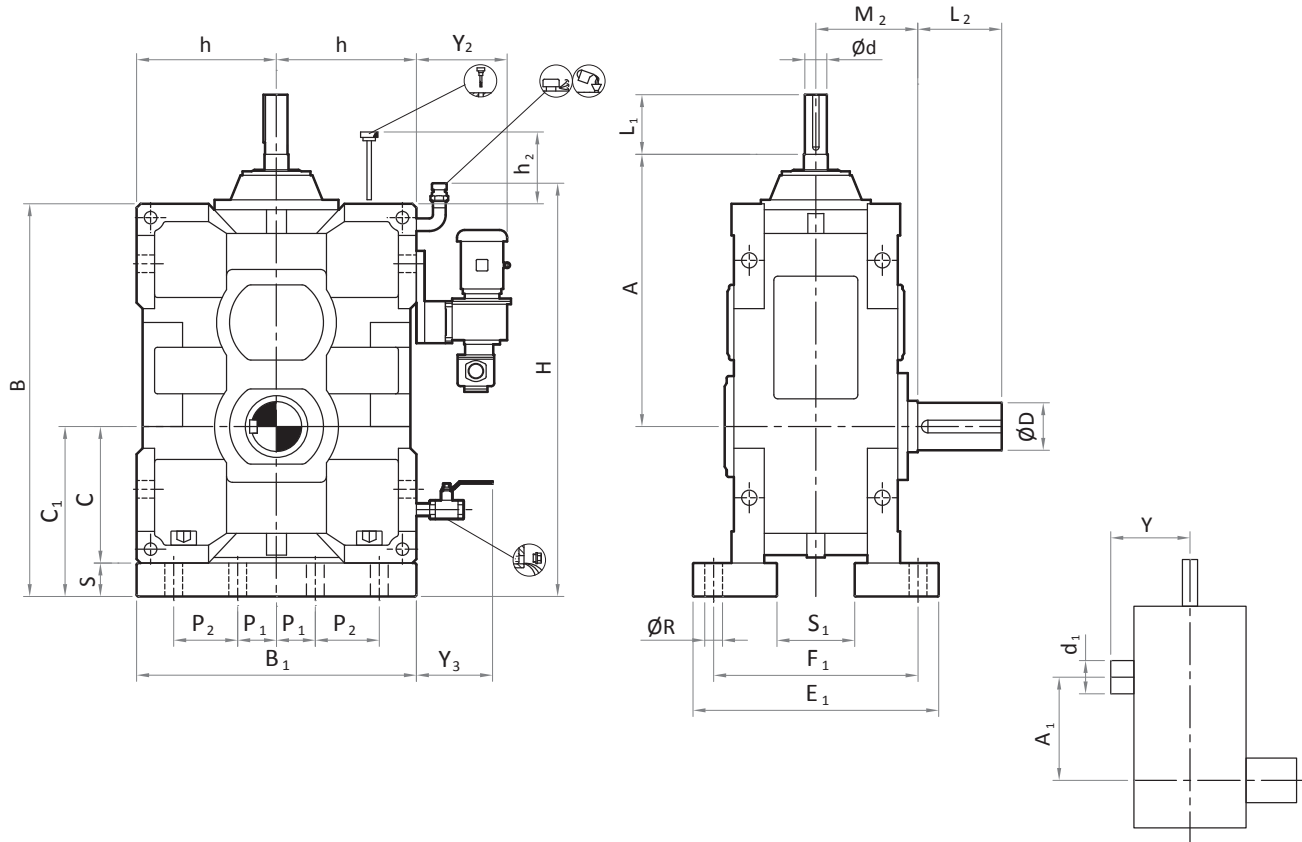

Size	Input Shaft				Output Shaft				Backstop			Weight (Kg) ¹⁾	Oil Quantity (Liters) ¹⁾
	i = 5 - 12.5		i = 14 - 18										
	i = 5 - 14		i = 16 - 20										
	i = 5.6 - 16		i = 18 - 22.4										
	d	L ₁	d	L ₁	D	L ₂	M ₂	M	A ₁	d ₁	Y		
712	28	85	20	80	45	90	155	125	90	95	185	90	4
713	30	85	30	85	45	90	155	125	100	105	190	100	6
714	35	90	32	90	60	120	195	170	130	150	255	200	9
715	45	110	35	90	80	160	210	170	160	175	275	250	10
716	55	120	45	110	90	160	220	200	186	210	320	410	17
717	55	120	45	110	110	210	220	200	205	210	320	455	20
718	70	150	55	120	120	210	255	235	232	245	375	780	37
719	70	150	55	120	130	240	255	235	263	245	375	860	40

Size	Foundation																
	A	B	B ₁	C	C ₁ ^{-0.5}	E ₁	F ₁	h ^{-0.5}	H ¹⁾	h ₂ ¹⁾	P ₁	P ₂	R	S	S ₁	Y ₂ ¹⁾	Y ₃ ¹⁾
712	305	405	300	145	170	295	255	150	510	240	40	70	14	25	110	200	160
713	335	440	300	155	180	295	255	150	540	240	40	70	14	25	110	200	160
714	400	530	400	190	220	400	350	200	650	350	60	90	18	30	165	200	170
715	485	610	400	220	250	400	350	200	720	350	60	90	18	30	165	200	170
716	536	741	580	265	295	465	410	290	870	400	120	120	23	30	210	350	180
717	555	780	580	285	315	465	410	290	900	400	120	120	23	30	210	350	180
718	657	892	700	315	360	570	515	350	1000	460	130	130	27	45	245	350	180
719	688	953	700	345	390	570	515	350	1060	460	130	130	27	45	245	350	180

1) Approximate values

Bevel Helical gear units over driven mounting position

5.3 Type B2O - Gear unit dimensions, Two stage, Size 720 to 725

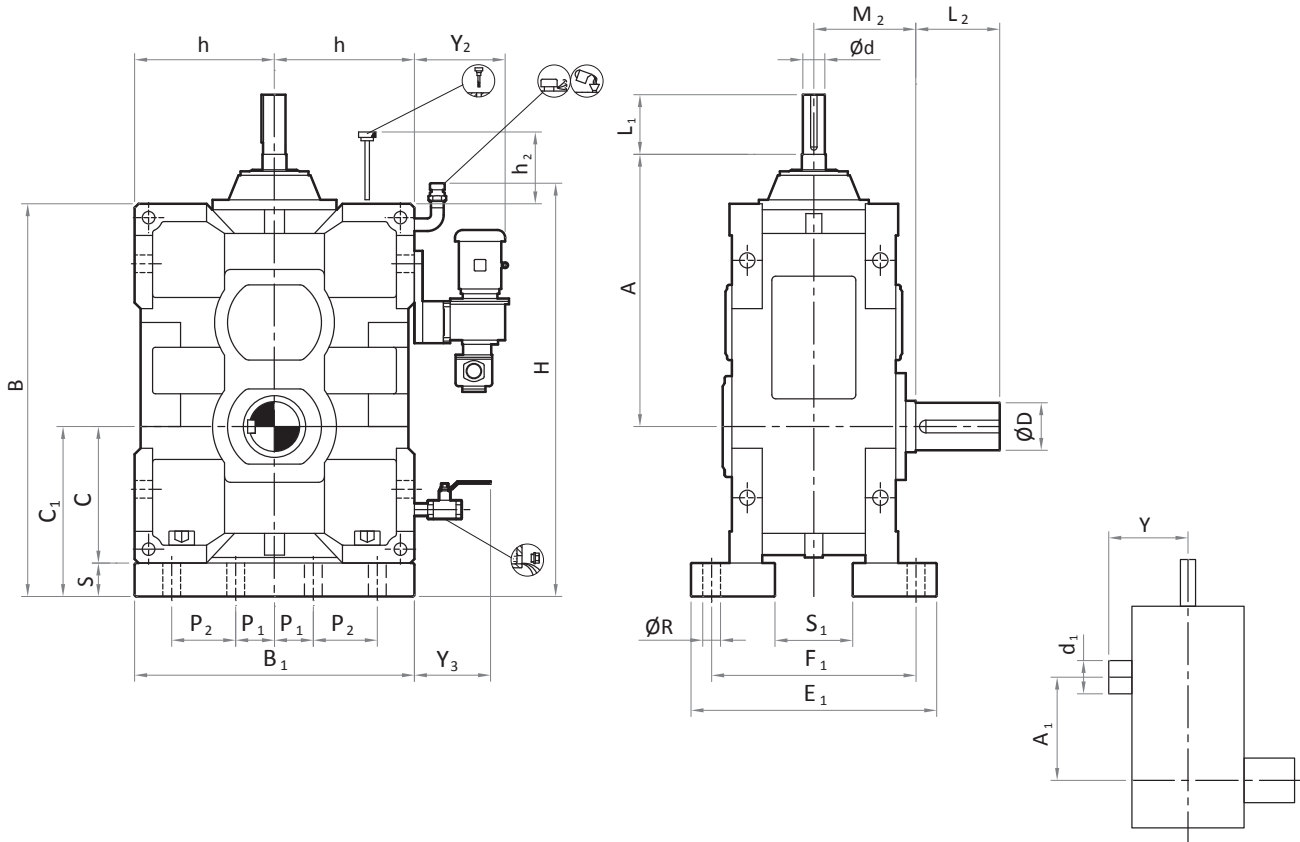

Size	Input Shaft				Output Shaft				Backstop			Weight (Kg) ¹⁾	Oil Quantity (Liters) ¹⁾
	i = 5 - 12.5		i = 14 - 18										
	i = 5 - 14		i = 16 - 20										
	i = 5.6 - 16		i = 18 - 22.4										
	d	L ₁	d	L ₁	D	L ₂	M ₂	M	A ₁	d ₁	Y		
720	80	160	60	130	135	250	290	275	270	290	430	1225	54
721	80	160	60	130	160	300	290	275	290	290	430	1335	108
722	90	170	70	150	170	300	345	330	328	290	475	2055	95
723	90	170	70	150	180	340	345	335	384	290	475	2180	104
724	110	190	80	160	200	340	390	360	376	400	520	2990	161
725	110	190	80	160	210	350	390	360	445	400	520	3335	175

Size	Foundation																
	A	B	B ₁	C	C ₁ ^{-0.5}	E ₁	F ₁	h ^{-0.5}	H ¹⁾	h ₂ ¹⁾	P ₁	P ₂	R	S	S ₁	Y ₂ ¹⁾	Y ₃ ¹⁾
720	760	1015	840	355	415	670	580	420	1120	500	140	200	33	60	270	350	220
721	780	1055	840	375	435	670	580	420	1160	500	140	200	33	60	270	350	220
722	933	1188	1000	430	490	800	710	500	1300	550	200	230	33	60	390	350	220
723	989	1304	1000	490	550	800	710	500	1420	550	200	230	33	60	390	350	220
724	1076	1406	1160	500	570	890	770	580	1520	700	220	260	39	70	410	350	220
725	1145	1545	1160	570	640	890	770	580	1660	700	220	260	39	70	410	350	220

1) Approximate values

Bevel Helical gear units

5.4 Type B2 – Gear unit shaft arrangement views

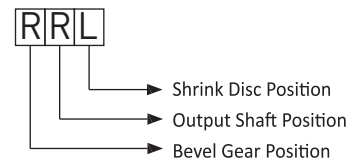
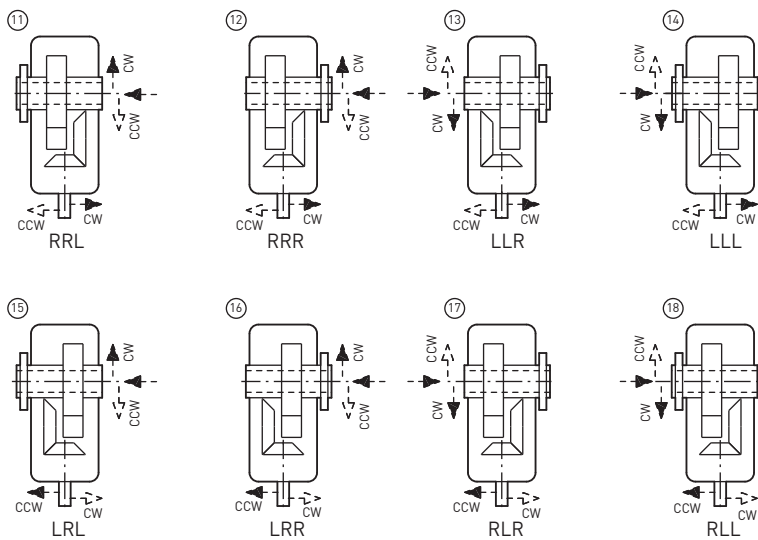
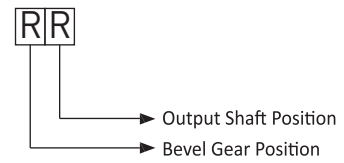
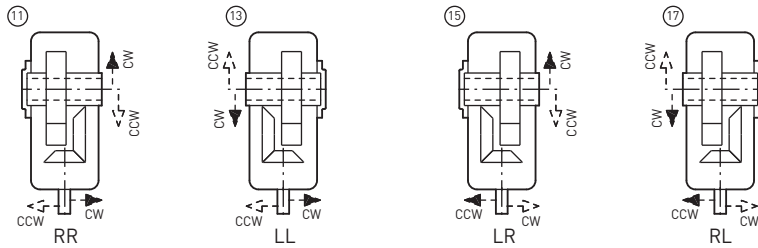
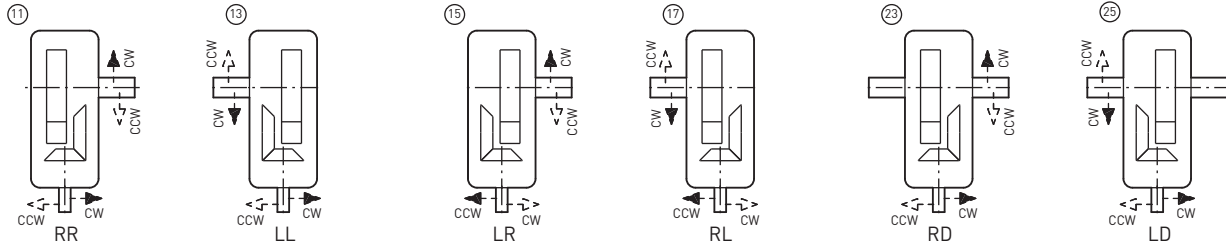

Intermediate Extension

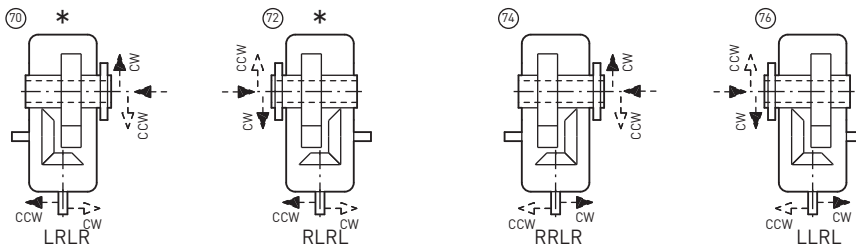
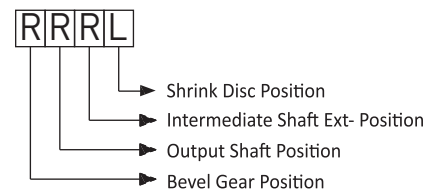
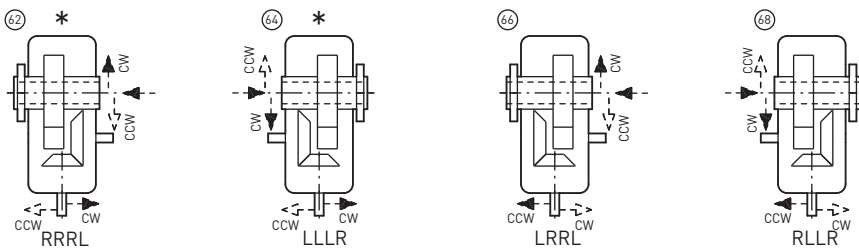
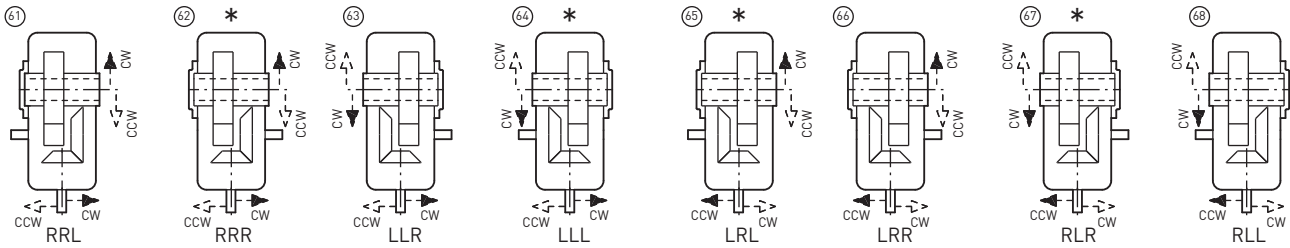
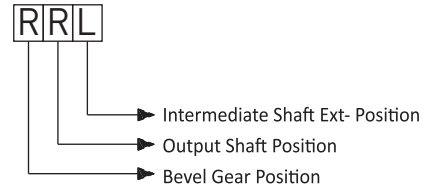
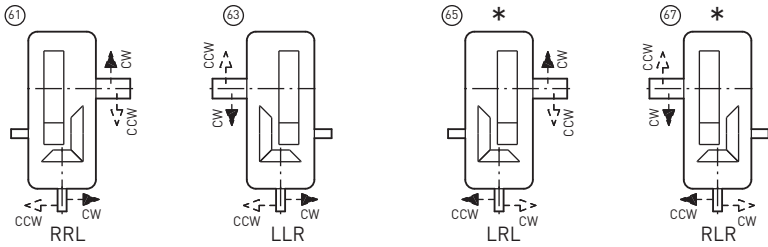

Holdback

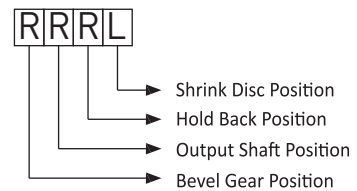
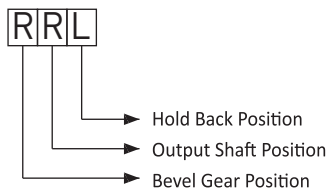
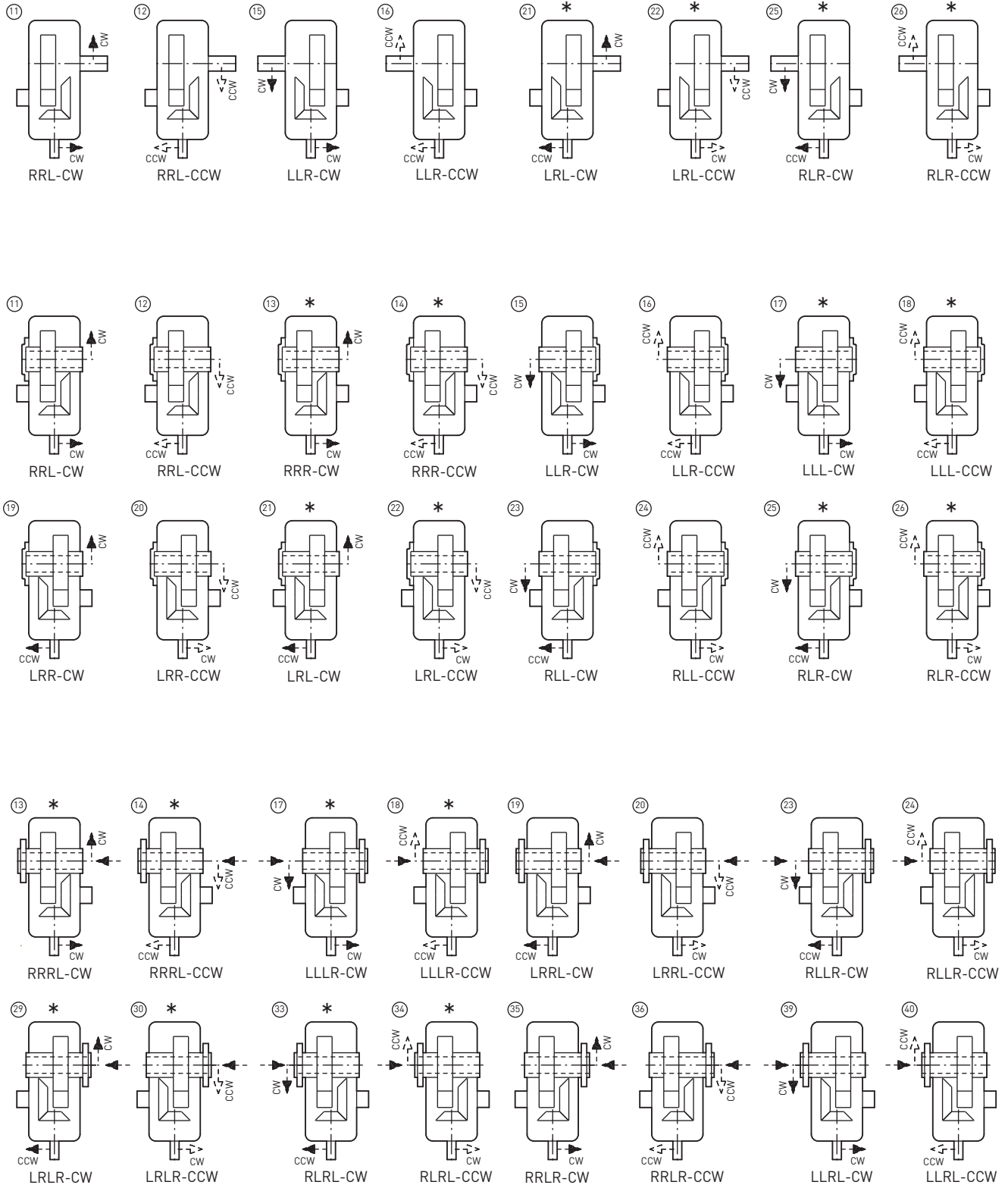

Intermediate Extension & Holdback

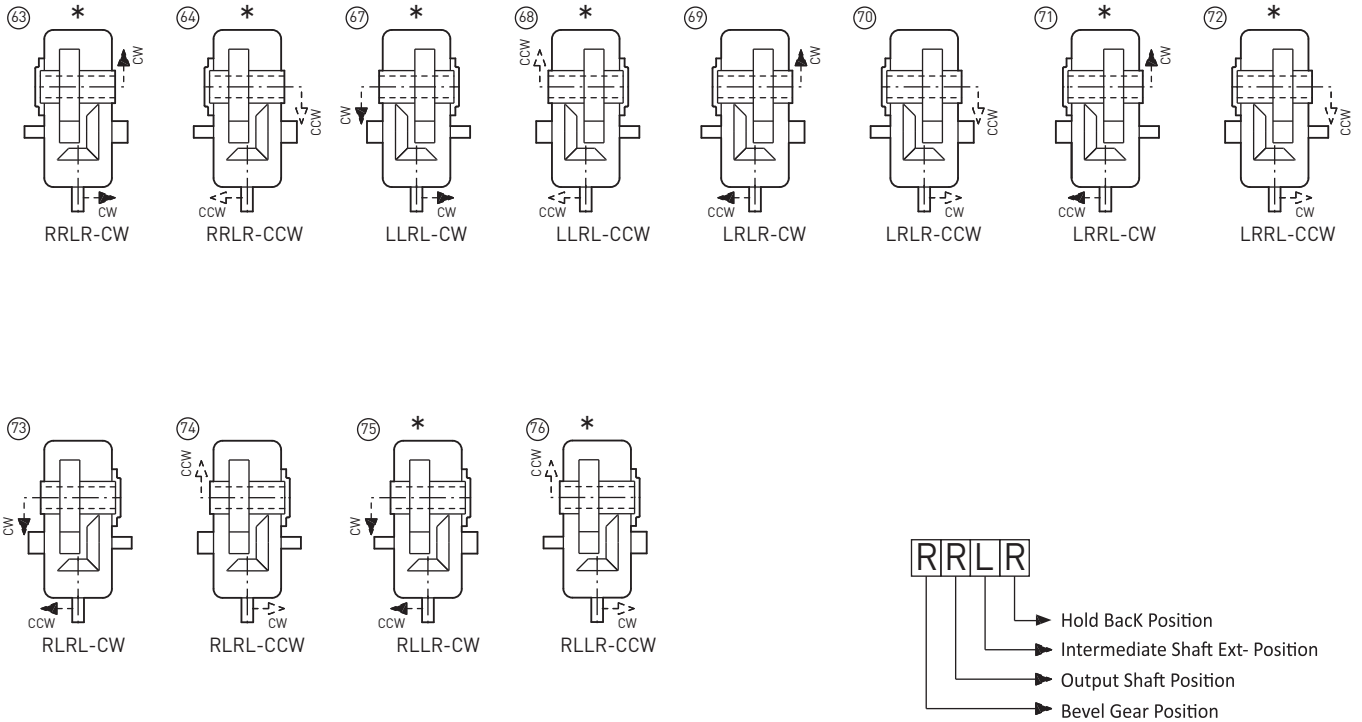

Bevel Helical gear units horizontal mounting position

5.5 Type B3H Gear unit dimensions, Three stage, Size 714 to 719

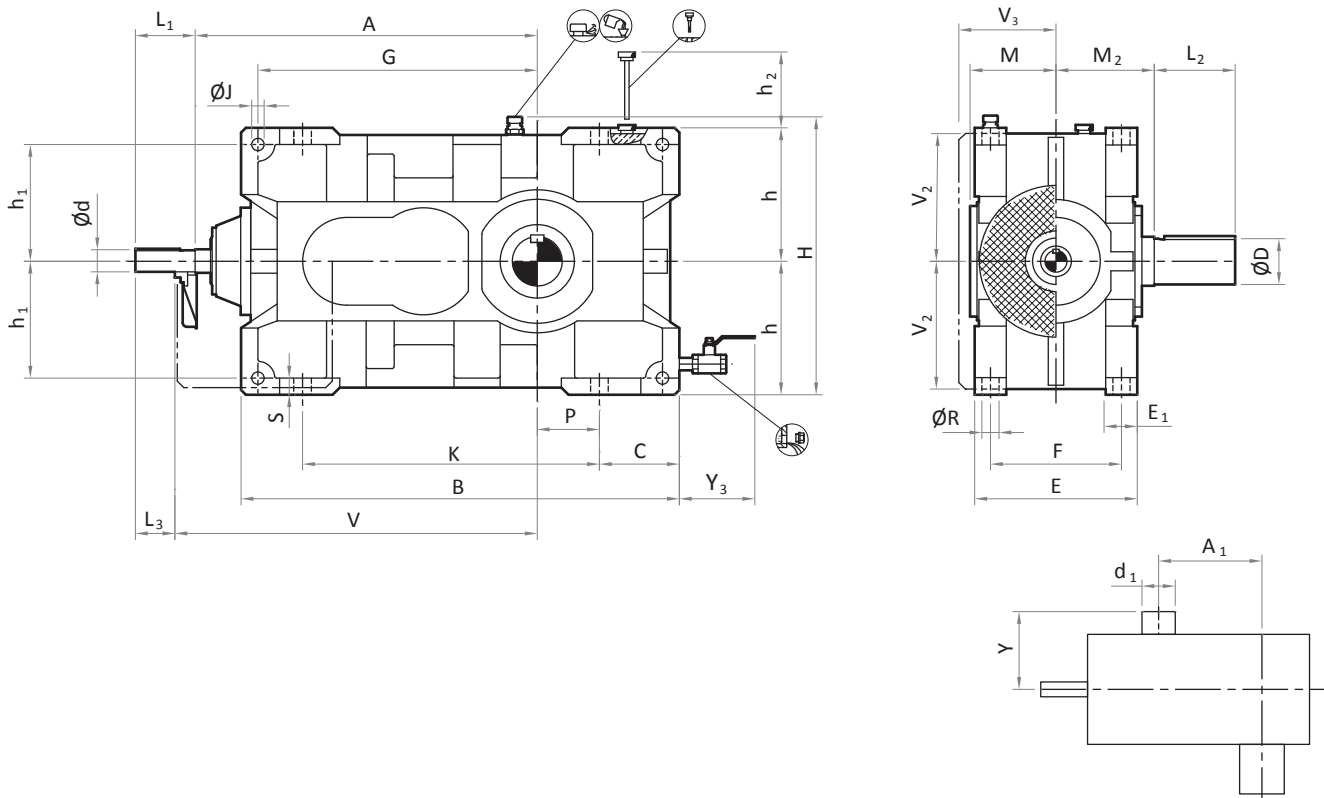

* Remove fan cover before installation

Size	Input Shaft						Mounting Dimension			Output Shaft				Backstop			Weight (Kg) ¹⁾	Oil Quantity (Liters) ¹⁾
	i = 12.5 - 50			i = 56 - 71														
	i = 16 - 63			i = 71 - 90														
	d	L ₁	L ₃	d	L ₁	L ₃	V	V ₂ ¹⁾	V ₃ ¹⁾	D	L ₂	M ₂	M	A ₁	d ₁	Y		
714	30	85	55	30	85	55	497	195	155	60	120	150	135	232	132	215	170	7
715	30	85	55	30	85	55	524	195	155	80	160	150	135	259	132	215	205	8
716	35	90	60	32	90	60	615	225	180	100	210	170	160	315	150	245	320	14
717	35	90	60	32	90	60	652	225	180	110	210	170	160	352	150	245	365	15
718	45	110	80	35	90	60	750	272	210	120	210	200	185	395	190	290	550	26
719	45	110	80	35	90	60	799	272	210	130	240	200	185	444	190	290	630	29

Size	Foundation																
	A	B	C	E	E ₁	F	G	h ^{-0.5}	h ₁	H ¹⁾	h ₂ ¹⁾	J	K	P	R	S	Y ₃ ¹⁾
714	467	570	95	250	56	200	371	200	176	450	300	23	380	80	18	24	150
715	494	632	95	250	56	200	398	200	176	450	300	23	445	115	18	24	150
716	585	750	145	270	55	224	475	230	200	510	405	23	500	100	18	28	180
717	622	827	145	270	55	224	512	230	200	510	405	23	580	140	18	28	180
718	720	910	165	322	69	270	580	280	245	610	415	27	630	130	23	35	180
719	769	1009	165	322	69	270	629	280	245	610	415	27	720	180	23	35	180

1) Approximate values

Bevel Helical gear units horizontal mounting position

5.5 Type B3H Gear unit dimensions, Three stage, Size 720 to 725

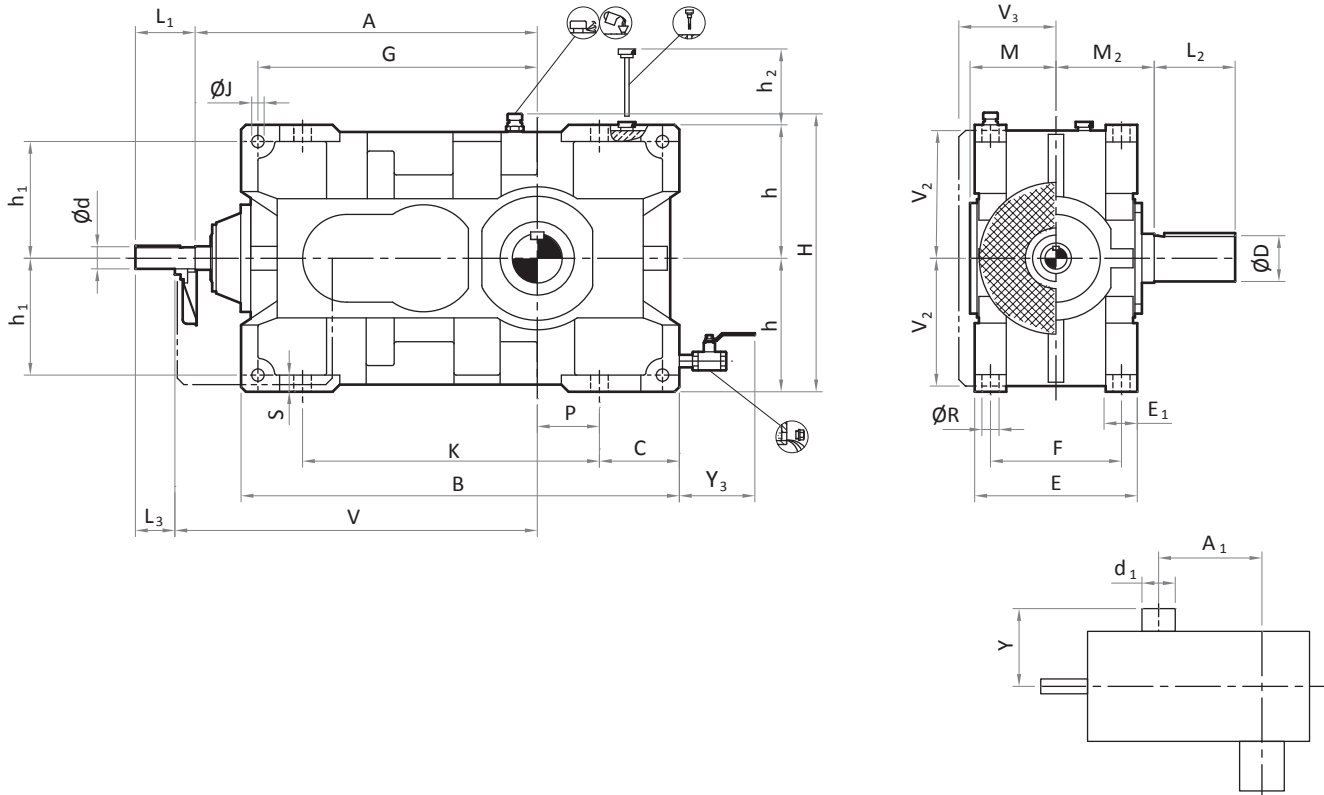

* Remove fan cover before installation

Size	Input Shaft						Mounting Dimension			Output Shaft				Backstop			Weight (Kg) ¹⁾	Oil Quantity (Liters) ¹⁾
	i = 12.5 - 50			i = 56 - 71														
	i = 16 - 63			i = 71 - 90														
	d	L ₁	L ₃	d	L ₁	L ₃	V	V ₂ ¹⁾	V ₃ ¹⁾	D	L ₂	M ₂	M	A ₁	d ₁	Y		
720	55	120	90	45	110	80	833	312	255	140	250	240	230	453	210	350	905	42
721	55	120	90	45	110	80	882	312	255	160	300	240	230	502	210	350	1050	45
722	70	150	120	55	120	90	1011	372	285	170	300	270	260	556	245	395	1510	72
723	70	150	120	55	120	90	1072	372	285	180	340	270	260	617	245	395	1715	74
724	80	160	130	60	130	100	1167	430	340	200	340	335	310	647	290	470	2375	132
725	80	160	130	60	130	100	1232	430	340	210	350	335	310	712	290	470	2685	133

Size	Foundation																	
	A	B	C	E	E ₁	F	G	h ^{-0.5}	h ₁	H ¹⁾	h ₂ ¹⁾	J	K	P	R	S	Y ₃ ¹⁾	
720	803	1045	175	400	80	340	670	320	280	690	500	33	730	160	27	40	250	
721	852	1144	175	400	80	340	719	320	280	690	500	33	830	210	27	40	250	
722	981	1260	210	474	100	400	810	380	330	810	650	39	900	190	33	50	225	
723	1042	1381	210	474	100	400	871	380	330	810	650	39	1010	250	33	50	225	
724	1137	1455	220	560	110	475	950	440	380	930	700	45	1055	235	39	60	225	
725	1202	1585	220	560	110	475	1015	440	380	930	700	45	1190	300	39	60	225	

1) Approximate values

Bevel Helical gear units vertical mounting position

5.6 Type B3V - Gear unit dimensions, Three stage, Size 714 to 719

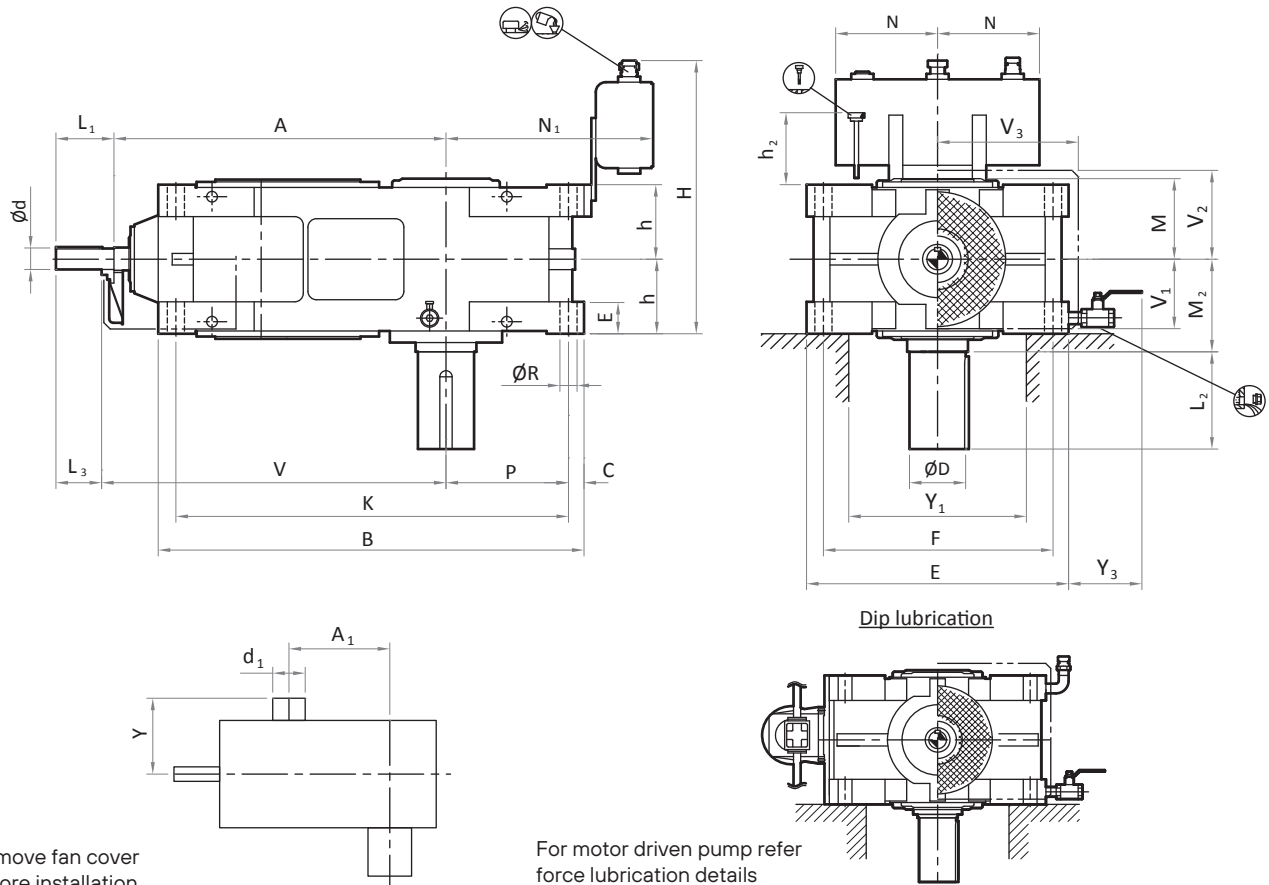

* Remove fan cover before installation

For motor driven pump refer force lubrication details

Size	Input Shaft						Mounting Dimension			Output Shaft				Backstop			Weight (Kg) ¹⁾	Oil Quantity (Liters) ¹⁾
	i = 12.5 - 50			i = 56 - 71														
	i = 16 - 63			i = 71 - 90														
	d	L ₁	L ₃	d	L ₁	L ₃	V	V ₂ ¹⁾	V ₃ ¹⁾	D	L ₂	M ₂	M	A ₁	d ₁	Y		
714	30	85	55	30	85	55	497	155	230	60	120	150	135	232	132	215	170	14
715	30	85	55	30	85	55	524	155	230	80	160	150	135	259	132	215	205	17
716	35	90	60	32	90	60	615	180	260	100	210	170	160	315	150	245	320	30
717	35	90	60	32	90	60	652	180	260	110	210	170	160	352	150	245	365	31
718	45	110	80	35	90	60	750	210	315	120	210	200	185	395	190	290	550	54
719	45	110	80	35	90	60	799	210	315	130	240	200	185	444	190	290	630	60

Size	Foundation															
	A	B	C	E	E ₁	F	h ^{-0.5}	H ¹⁾	h ₂ ¹⁾	K	N	P	R	Y ₁ ¹⁾	Y ₃ ¹⁾	N ₁
714	467	570	24	400	56	352	125	480	185	522	190	151	23	275	160	325
715	494	632	24	400	56	352	125	480	185	584	190	186	23	275	160	360
716	585	750	30	460	55	400	135	500	200	690	190	215	23	280	180	395
717	622	827	30	460	55	400	135	500	200	767	190	255	23	280	180	435
718	720	910	35	560	69	490	161	550	240	840	190	260	27	350	180	445
719	769	1009	35	560	69	490	161	550	240	939	190	310	27	350	180	495

1) Approximate values

Bevel Helical gear units vertical mounting position

5.6 Type B3V - Gear unit dimensions, Three stage, Size 720 to 725

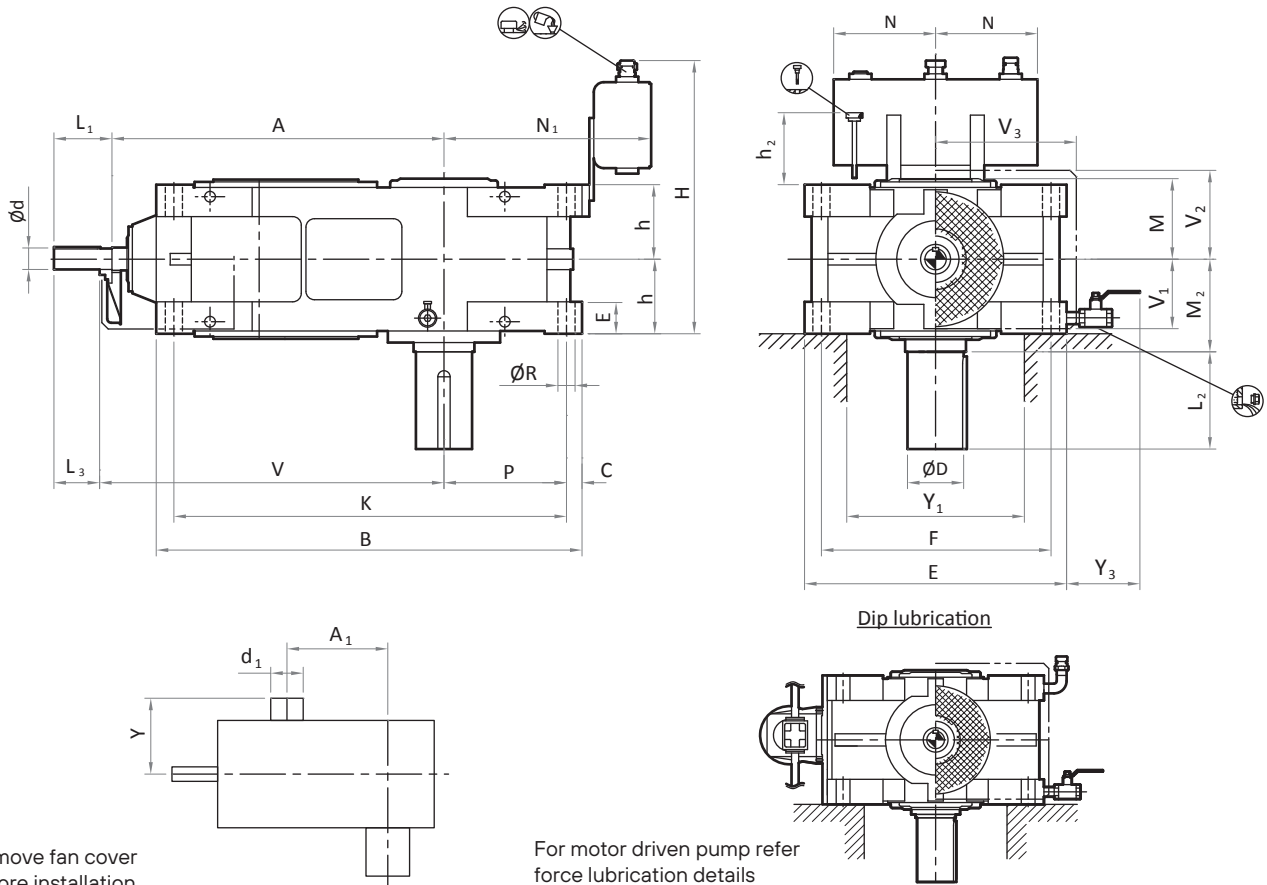

Size	Input Shaft						Mounting Dimension			Output Shaft				Backstop			Weight (Kg) ¹⁾	Oil Quantity (Liters) ¹⁾
	i = 12.5 - 50			i = 56 - 71														
	i = 16 - 63			i = 71 - 90														
	d	L ₁	L ₃	d	L ₁	L ₃	V	V ₂ ¹⁾	V ₃ ¹⁾	D	L ₂	M ₂	M	A ₁	d ₁	Y		
720	55	120	90	45	110	80	833	255	355	140	250	240	230	453	210	350	905	905
721	55	120	90	45	110	80	882	255	355	160	300	240	230	502	210	350	1050	1050
722	70	150	120	55	120	90	1011	285	415	170	300	270	260	556	245	395	1510	1510
723	70	150	120	55	120	90	1072	285	415	180	340	270	260	617	245	395	1715	1715
724	80	160	130	60	130	100	1167	340	480	200	340	335	310	647	290	470	2375	2375
725	80	160	130	60	130	100	1232	340	480	210	350	335	310	712	290	470	2685	2685

Size	Foundation															
	A	B	C	E	E ₁	F	h ^{-0.5}	H ¹⁾	h ₂ ¹⁾	K	N	P	R	Y ₁ ¹⁾	Y ₃ ¹⁾	N ₁
720	803	1045	40	640	80	560	200	750	300	965	300	295	33	420	230	550
721	852	1144	40	640	80	560	200	750	300	1064	300	345	33	420	230	600
722	981	1260	50	760	100	660	237	820	350	1160	300	360	39	530	230	615
723	1042	1381	50	760	100	660	237	820	350	1281	300	420	39	530	230	675
724	1137	1455	50	880	110	760	280	900	420	1355	300	405	45	610	230	675
725	1202	1585	50	880	110	760	280	900	420	1485	300	470	45	610	230	735

1) Approximate values

Bevel Helical gear units over driven mounting position

5.7 Type B30 - Gear unit dimensions, Three stage, Size 714 to 719

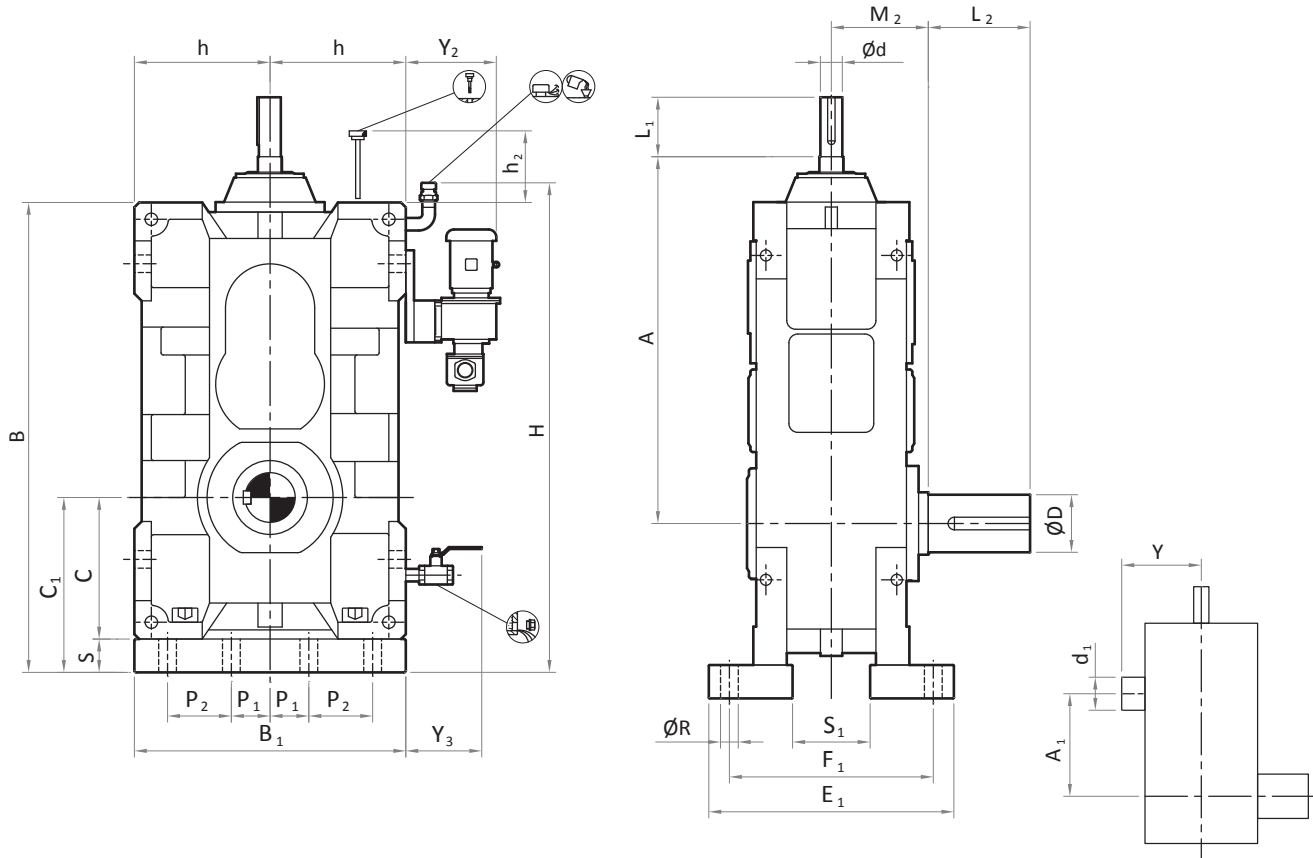

Size	Input Shaft				Output Shaft			Backstop			Weight (Kg) ¹⁾	Oil Quantity (Liters) ¹⁾
	i = 12.5 - 50		i = 56 - 71									
	i = 16 - 63		i = 71 - 90									
	d	L ₁	d	L ₁	D	L ₂	M ₂	A ₁	d ₁	Y		
714	30	85	30	85	60	120	150	232	132	215	190	8
715	30	85	30	85	80	160	150	259	132	215	225	9
716	35	90	32	90	100	210	170	315	150	245	345	15
717	35	90	32	90	110	210	170	352	150	245	390	16
718	45	110	35	90	120	210	200	395	190	290	600	28
719	45	110	35	90	130	240	200	444	190	290	680	31

Size	Foundation																
	A	B	B ₁	C	C ₁ ^{-0.5}	E ₁	F ₁	h ^{-0.5}	H ¹⁾	h ₂ ¹⁾	P ₁	P ₂	R	S	S ₁	Y ₂ ¹⁾	Y ₃ ¹⁾
714	467	600	400	175	205	340	295	200	690	350	70	80	18	30	120	250	160
715	494	662	400	210	240	340	295	200	750	350	70	80	18	30	120	250	160
716	585	780	460	245	275	390	335	230	875	400	90	90	18	30	150	315	180
717	622	857	460	285	315	390	335	230	950	400	90	90	18	30	150	315	180
718	720	950	560	295	335	470	410	280	1050	450	100	120	23	40	175	370	180
719	769	1049	560	345	385	470	410	280	1150	450	100	120	23	40	175	370	180

1) Approximate values

Bevel Helical gear units over driven mounting position

5.7 Type B30 - Gear unit dimensions, Three stage, Size 720 to 725

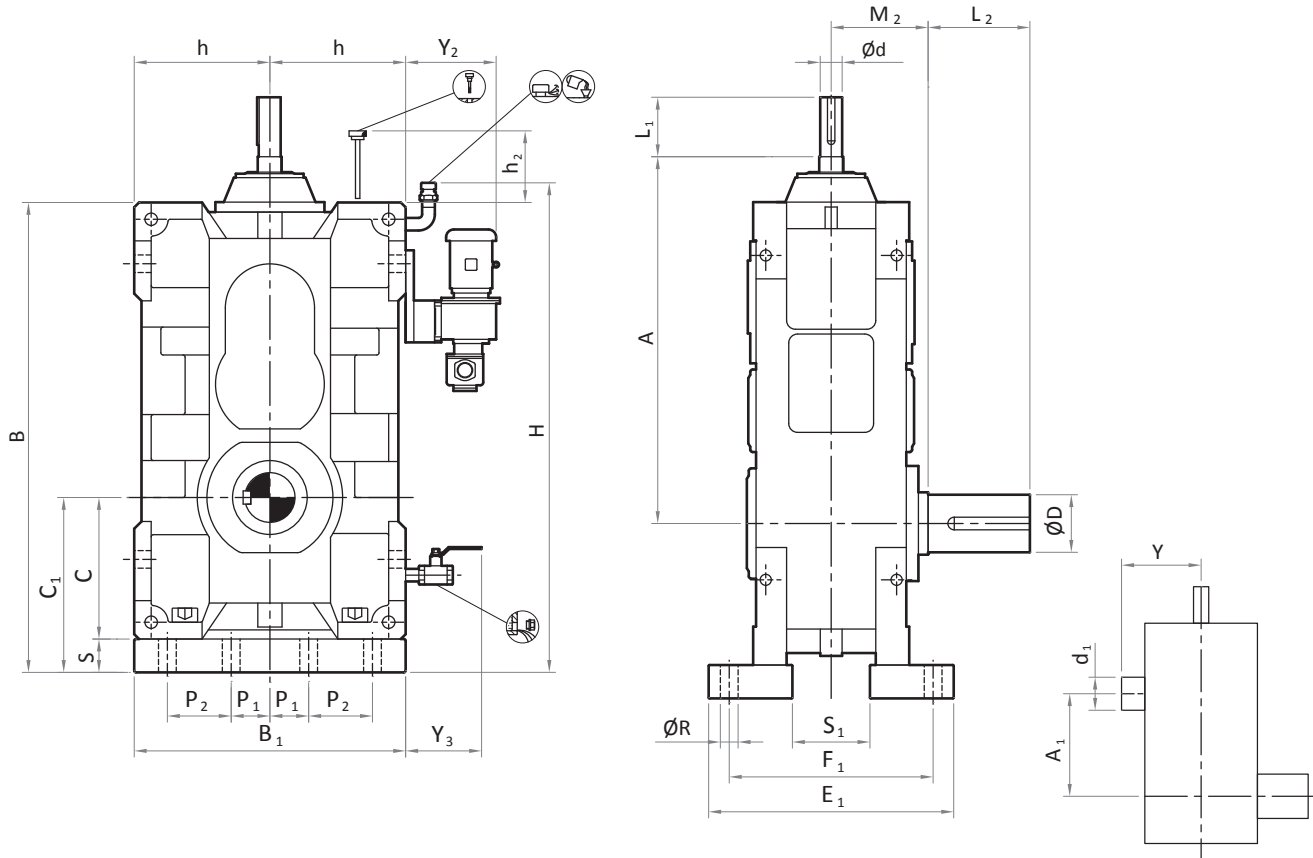

Size	Input Shaft				Output Shaft			Backstop			Weight (Kg) ¹⁾	Oil Quantity (Liters) ¹⁾
	i = 12.5 - 50		i = 56 - 71									
	i = 16 - 63		i = 71 - 90									
	d	L ₁	d	L ₁	D	L ₂	M ₂	A ₁	d ₁	Y		
720	55	120	45	110	140	250	240	453	210	350	985	45
721	55	120	45	110	160	300	240	502	210	350	1130	49
722	70	150	55	120	170	300	270	556	245	395	1650	78
723	70	150	55	120	180	340	270	617	245	395	1855	79
724	80	160	60	130	200	340	335	647	290	470	2590	142
725	80	160	60	130	210	350	335	712	290	470	2900	144

Size	Foundation																
	A	B	B ₁	C	C ₁ ^{-0.5}	E ₁	F ₁	h ^{-0.5}	H ¹⁾	h ₂ ¹⁾	P ₁	P ₂	R	S	S ₁	Y ₂ ¹⁾	Y ₃ ¹⁾
720	803	1095	640	335	385	540	470	320	1230	600	120	140	27	50	210	410	230
721	852	1194	640	385	435	540	470	320	1330	600	120	140	27	50	210	410	230
722	981	1320	760	400	460	650	560	380	1450	700	140	180	33	60	245	470	230
723	1042	1441	760	460	520	650	560	380	1580	700	140	180	33	60	245	470	230
724	1137	1525	880	455	525	760	660	440	1650	700	170	200	39	70	300	530	230
725	1202	1655	880	520	590	760	660	440	1780	700	170	200	39	70	300	530	230

1) Approximate values

Bevel Helical gear units

5.8 Type B3 – Gear unit shaft arrangement views

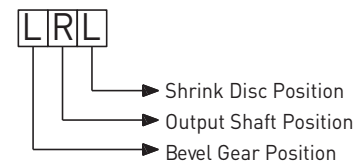
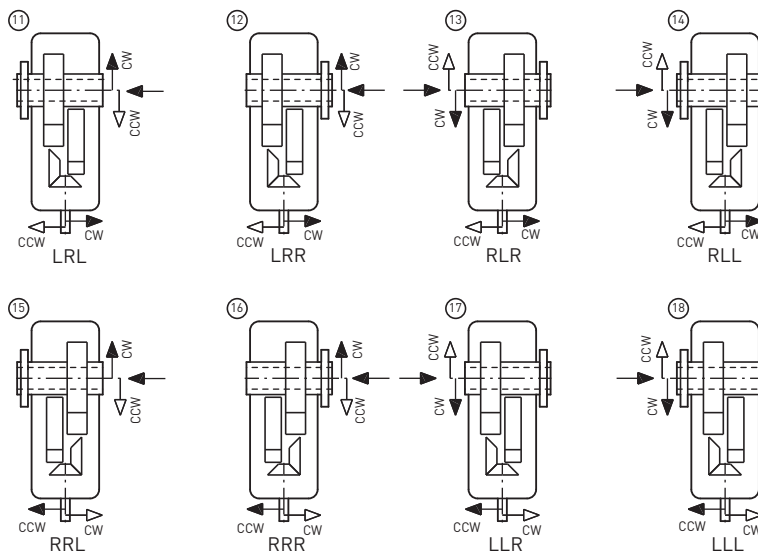
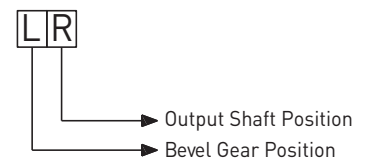
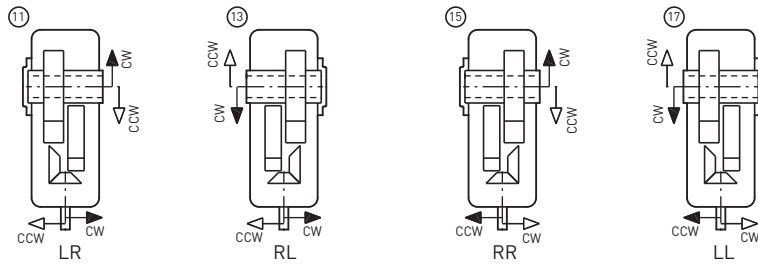
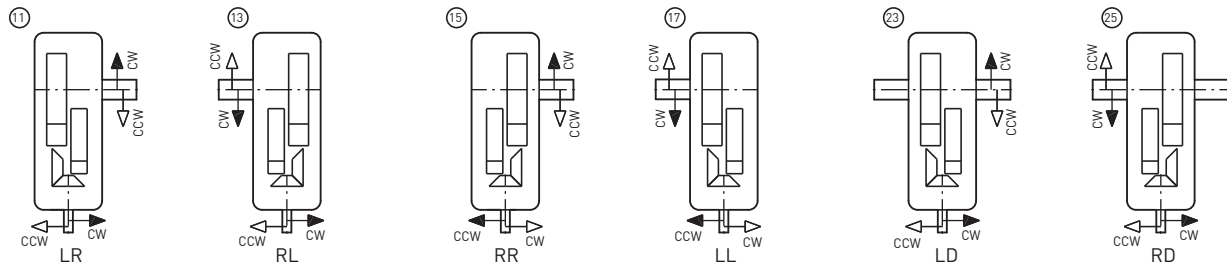

Intermediate Extension

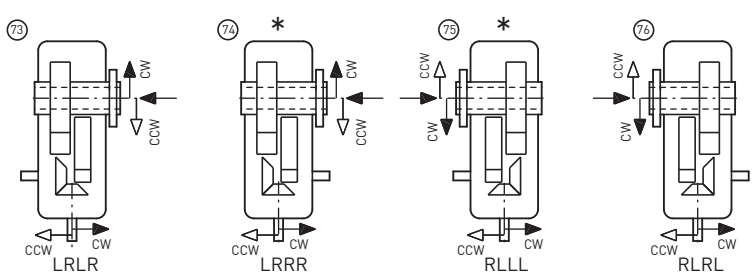
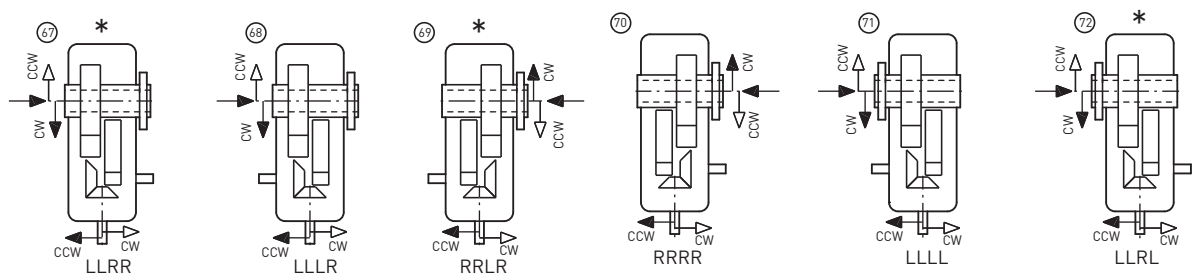
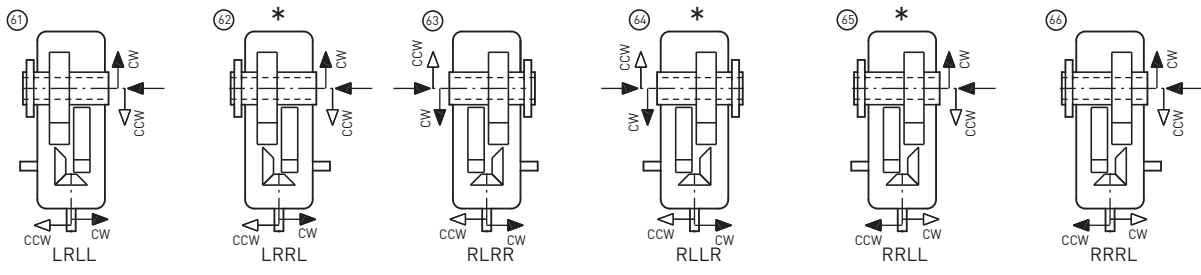
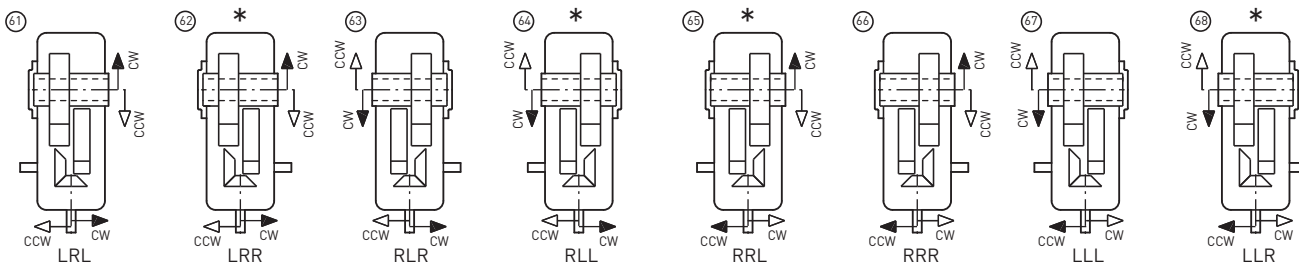
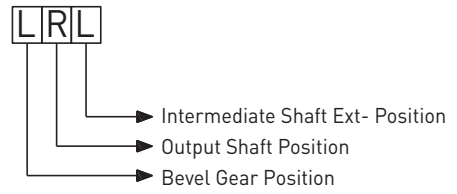
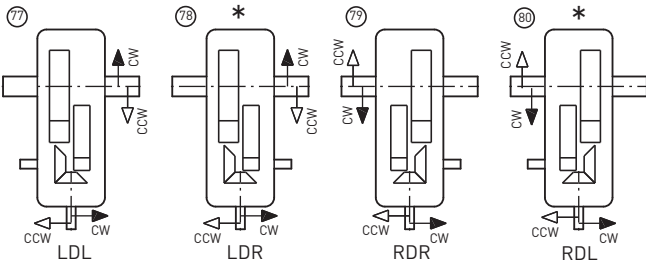
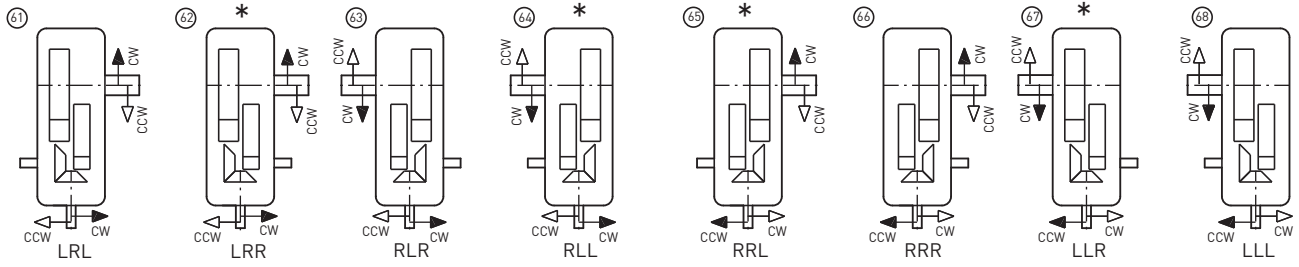

Holdback

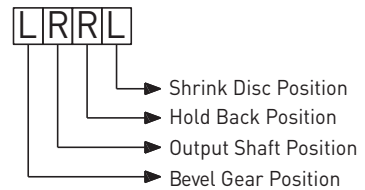
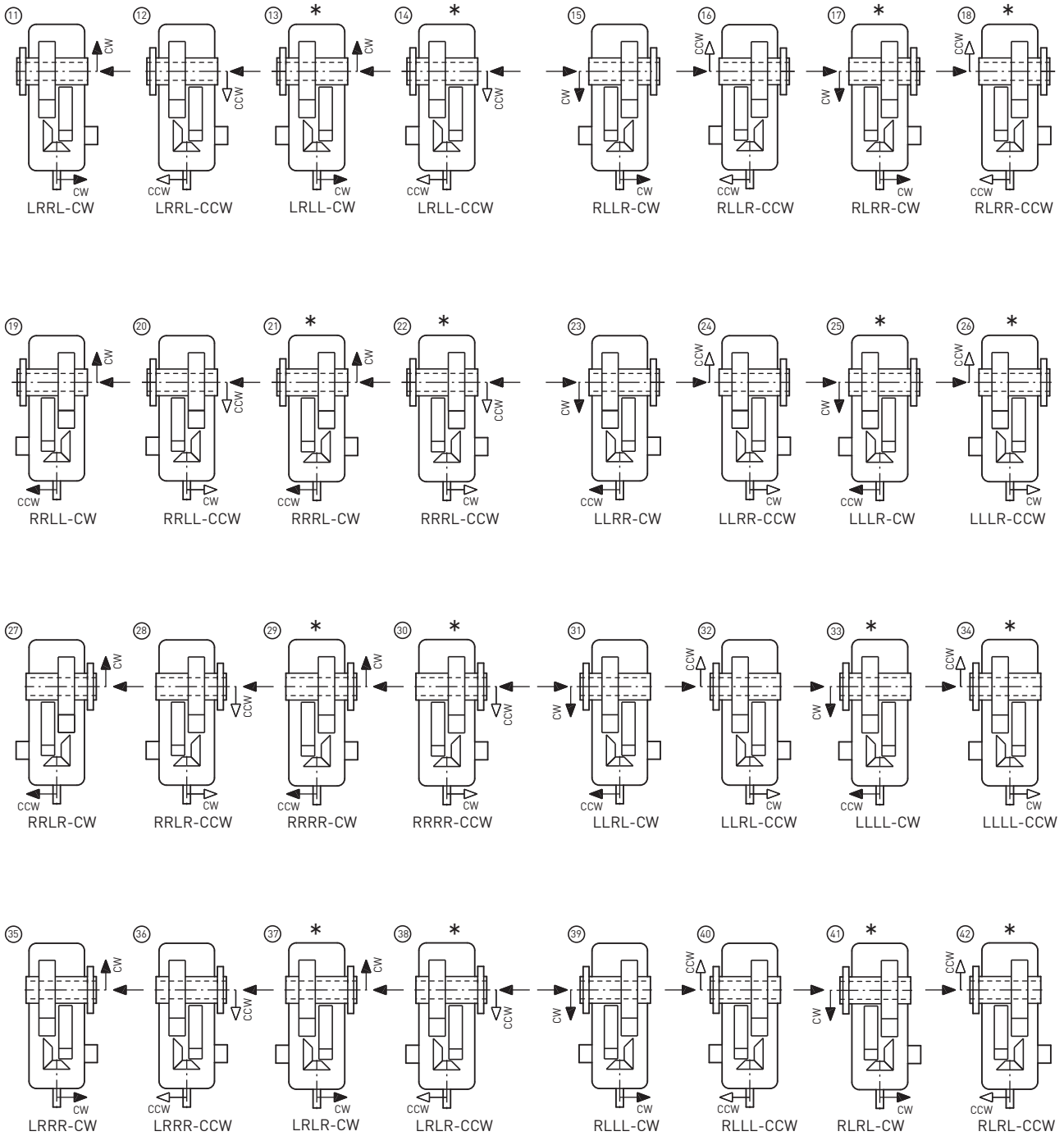

Holdback

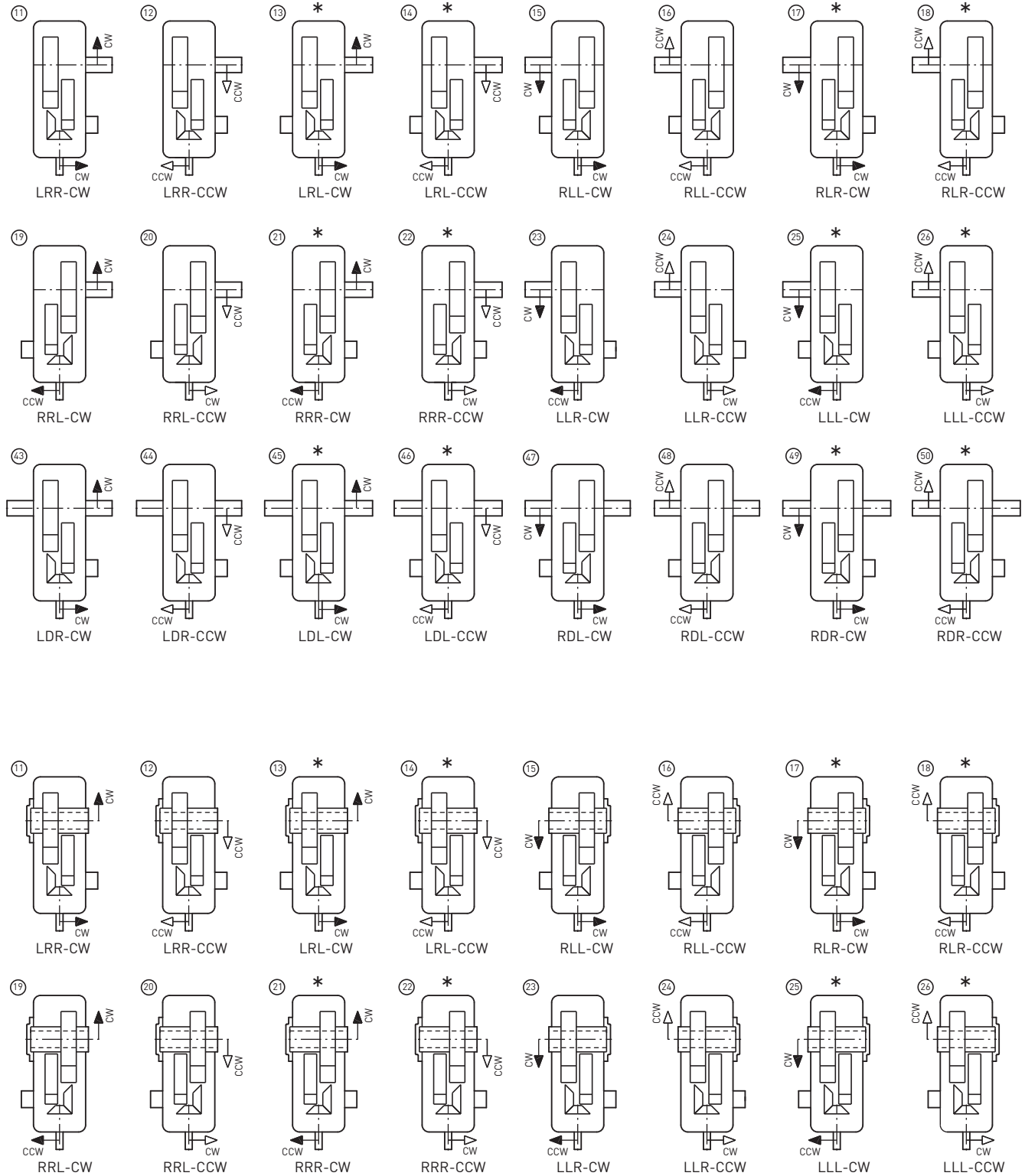

Intermediate Extension & Holdback

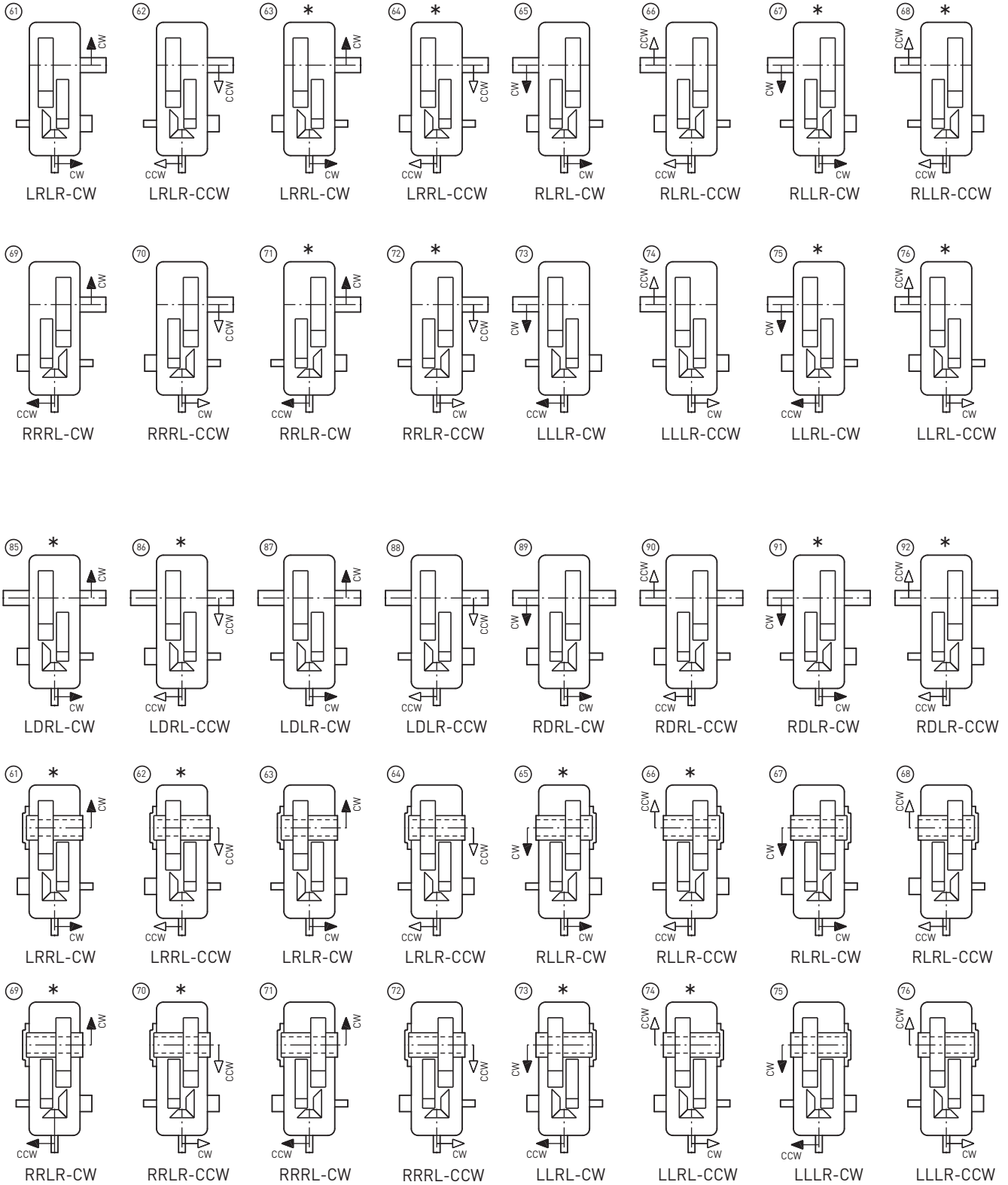

LRLR

- Hold Back Position
- Intermediate Shaft Ext- Position
- Output Shaft Position
- Bevel Gear Position

Intermediate Extension & Holdback

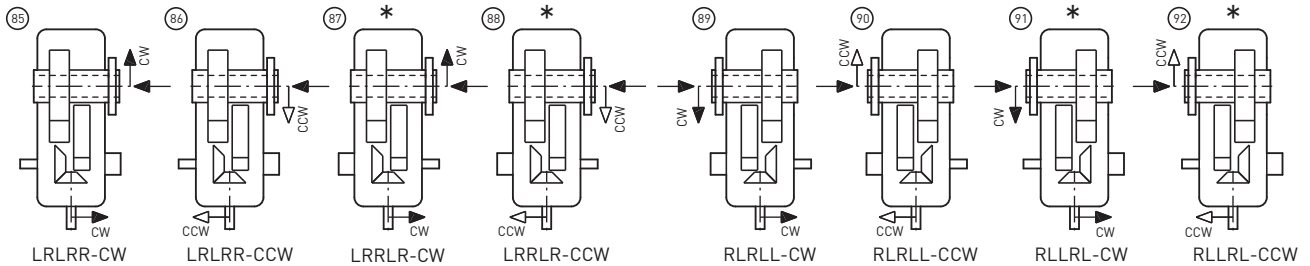
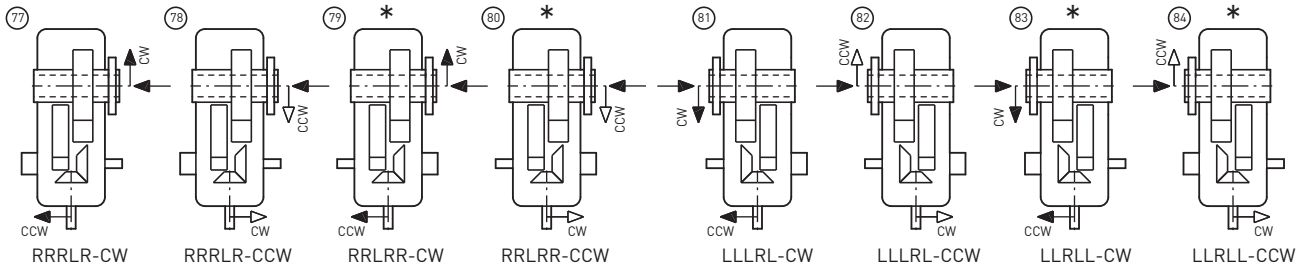
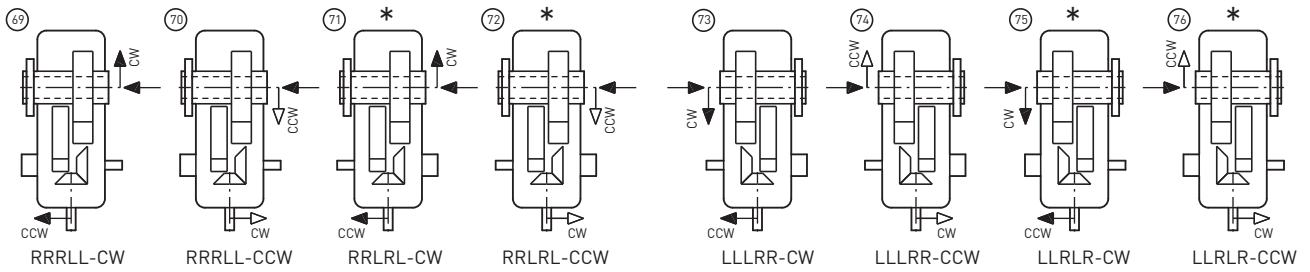
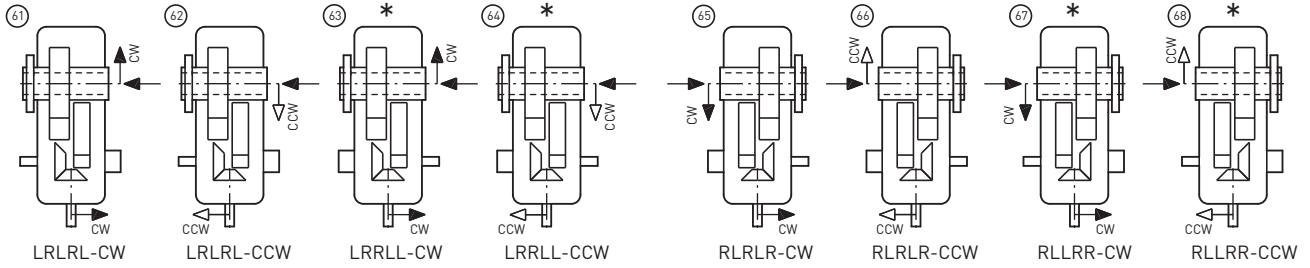

LRLRR

- Shrink Disc Position
- Hold Back Position
- Intermediate Shaft Ext- Position
- Output Shaft Position
- Bevel Gear Position

Bevel Helical gear units horizontal mounting position

5.9 Type B4H - Gear unit dimensions, Four stage, Size 716 to 719

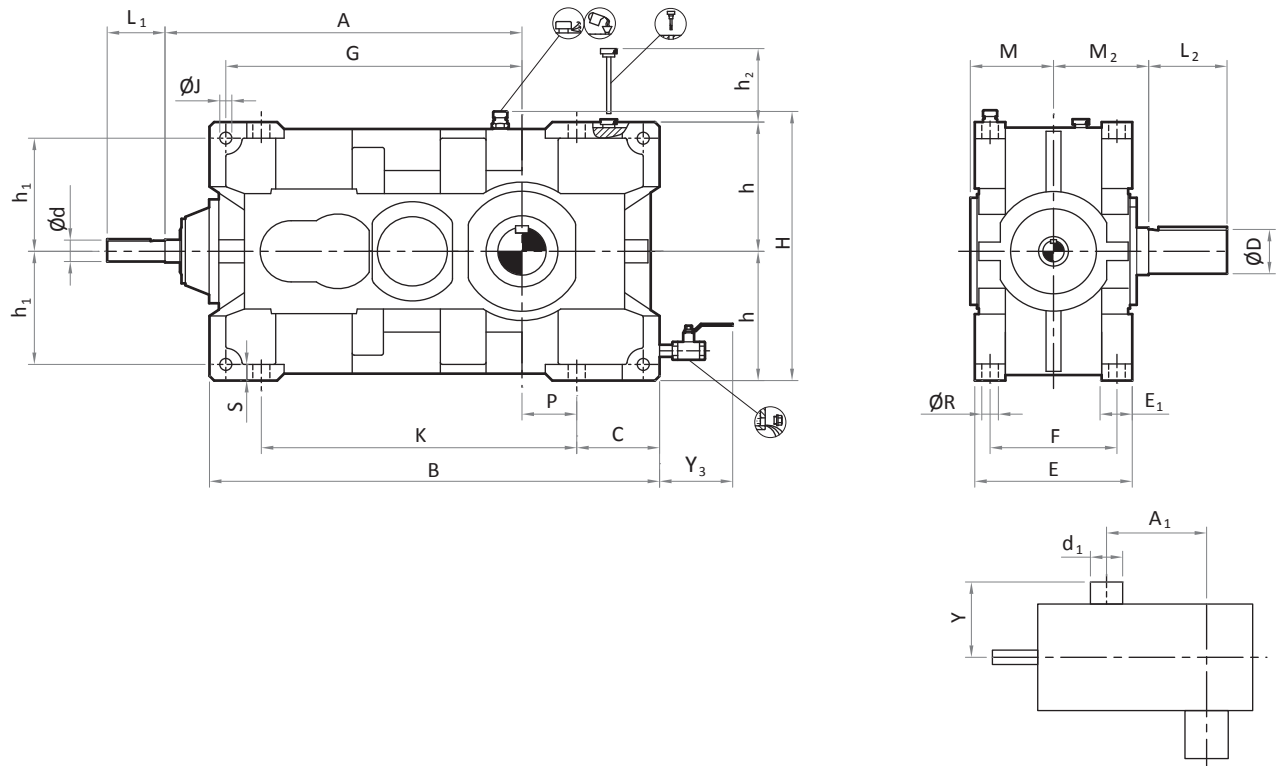

Size	Input Shaft						Output Shaft				Backstop			Weight (Kg) ¹⁾	Oil Quantity (Liters) ¹⁾
	i = 80 - 200		i = 224 - 315		i = 355		D	L ₂	M ₂	M	A ₁	d ₁	Y		
	d	L ₁	d	L ₁	d	L ₁									
716	28	85	20	80	20	80	100	210	170	160	405	95	220	335	16
717	28	85	20	80	20	80	110	210	170	160	442	95	220	385	17
718	30	85	30	85	22	80	120	210	200	185	495	132	255	575	30
719	30	85	30	85	22	80	130	240	200	185	544	132	255	650	32

Size	Foundation																
	A	B	C	E	E ₁	F	G	h ^{-0.5}	h ₁	H ¹⁾	h ₂ ¹⁾	J	K	P	R	S	Y ₃ ¹⁾
716	620	805	145	270	55	224	530	230	200	510	405	23	560	100	18	28	180
717	657	882	145	270	55	224	567	230	200	510	405	23	640	140	18	28	180
718	730	965	165	322	69	270	635	280	245	610	415	27	695	130	23	35	180
719	779	1064	165	322	69	270	684	280	245	610	415	27	795	180	23	35	180

1) Approximate values

Bevel Helical gear units horizontal mounting position

5.9 Type B4H - Gear unit dimensions, Four stage, Size 720 to 725

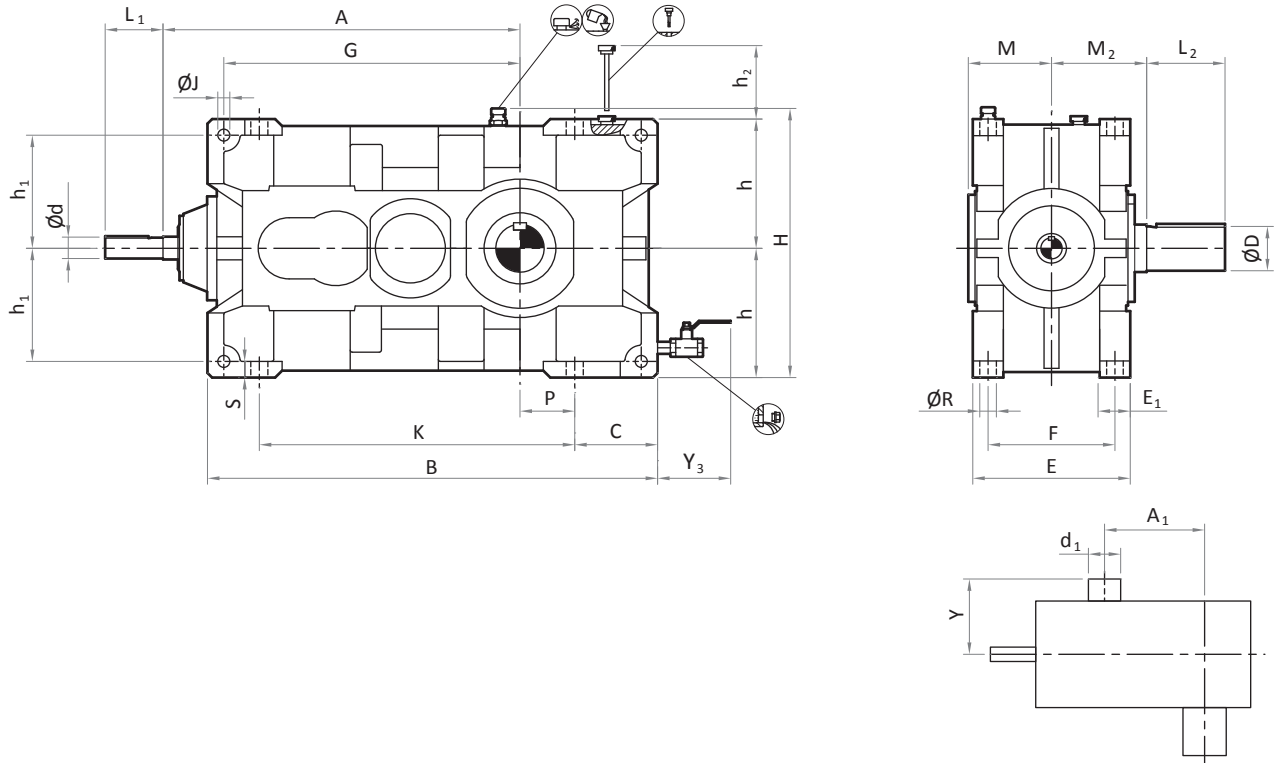

Size	Input Shaft						Output Shaft				Backstop			Weight (Kg) ¹⁾	Oil Quantity (Liters) ¹⁾
	i = 80 - 200		i = 224 - 315		i = 355		D	L ₂	M ₂	M	A ₁	d ₁	Y		
	d	L ₁	d	L ₁	d	L ₁									
720	35	90	32	90	32	90	140	250	240	230	583	140	315	930	49
721	35	90	32	90	32	90	160	300	240	230	632	140	315	1075	51
722	45	110	35	90	35	90	170	300	270	260	716	175	365	1505	79
723	45	110	35	90	35	90	180	340	270	260	777	175	365	1705	85
724	55	120	45	110	35	90	200	340	335	310	833	190	420	2405	142
725	55	120	45	110	35	90	210	350	335	310	898	190	420	2730	146

Size	Foundation																
	A	B	C	E	E ₁	F	G	h ^{-0.5}	h ₁	H ¹⁾	h ₂ ¹⁾	J	K	P	R	S	Y ₃ ¹⁾
720	853	1125	175	400	80	340	750	320	280	690	500	33	830	160	27	40	250
721	902	1224	175	400	80	340	799	320	280	690	500	33	930	210	27	40	250
722	1041	1355	210	474	100	400	915	380	330	810	650	39	1000	190	33	50	225
723	1102	1476	210	474	100	400	976	380	330	810	650	39	1120	250	33	50	225
724	1183	1540	220	560	110	475	1035	440	380	930	700	45	1165	235	39	60	225
725	1248	1670	220	560	110	475	1100	440	380	930	700	45	1290	300	39	60	225

1) Approximate values

Bevel Helical gear units vertical mounting position

5.10 Type B4V - Gear unit dimensions, Four stage, Size 716 to 719

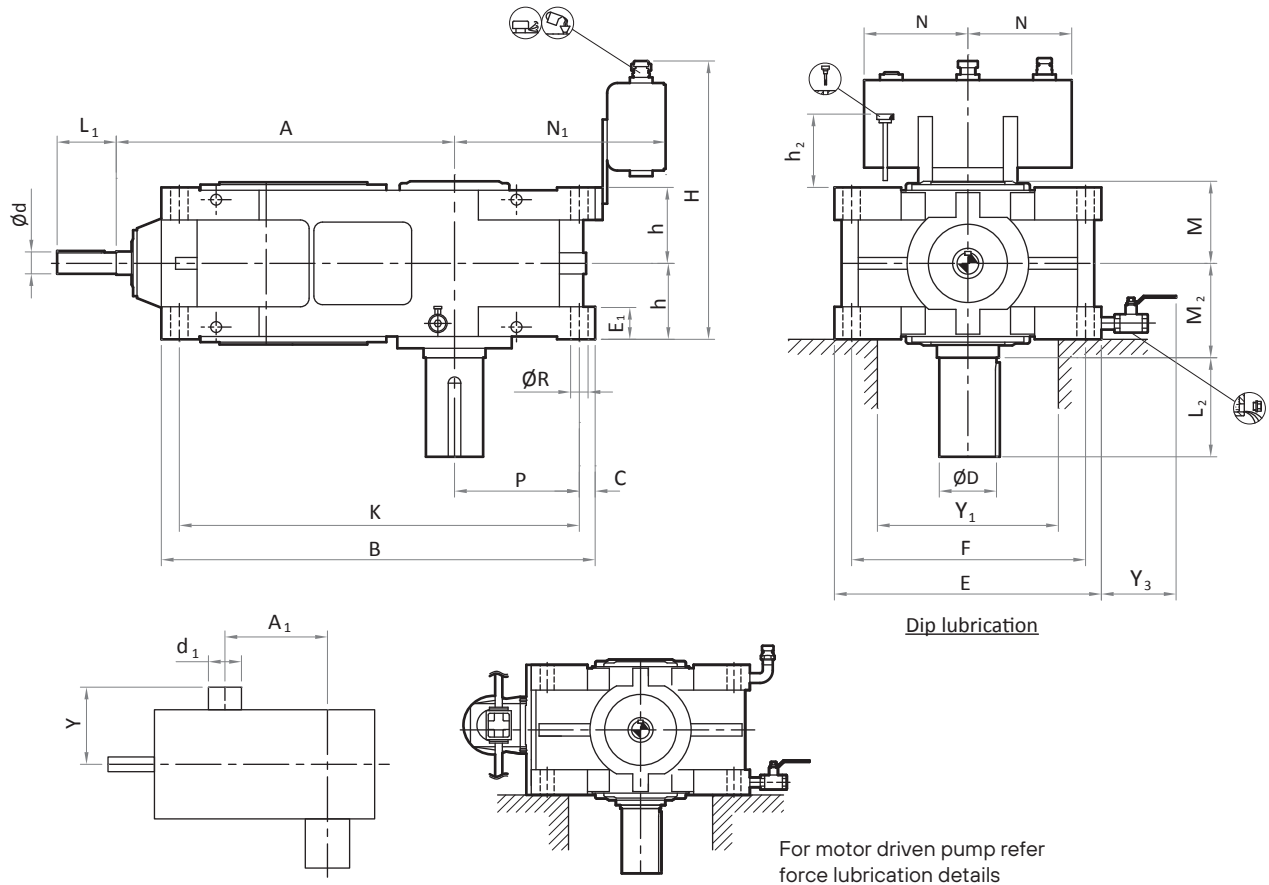

Size	Input Shaft						Output Shaft				Backstop			Weight (Kg) ¹⁾	Oil Quantity (Liters) ¹⁾
	i = 80 - 200		i = 224 - 315		i = 355		D	L ₂	M ₂	M	A ₁	d ₁	Y		
	d	L ₁	d	L ₁	d	L ₁									
716	28	85	20	80	20	80	100	210	170	160	405	95	220	335	32
717	28	85	20	80	20	80	110	210	170	160	442	95	220	385	36
718	30	85	30	85	22	80	120	210	200	185	495	132	255	575	63
719	30	85	30	85	22	80	130	240	200	185	544	132	255	650	66

Size	Foundation															
	A	B	C	E	E ₁	F	h ^{-0.5}	H ¹⁾	h ₂ ¹⁾	K	N	P	R	Y ₁ ¹⁾	Y ₃ ¹⁾	N ₁
716	620	805	30	460	55	400	135	500	200	745	190	215	23	280	180	395
717	657	882	30	460	55	400	135	500	200	822	190	255	23	280	180	435
718	730	965	35	560	69	490	161	550	240	895	190	260	27	350	180	445
719	779	1064	35	560	69	490	161	550	240	994	190	310	27	350	180	495

1) Approximate values

Bevel Helical gear units vertical mounting position

5.10 Type B4V - Gear unit dimensions, Four stage, Size 720 to 725

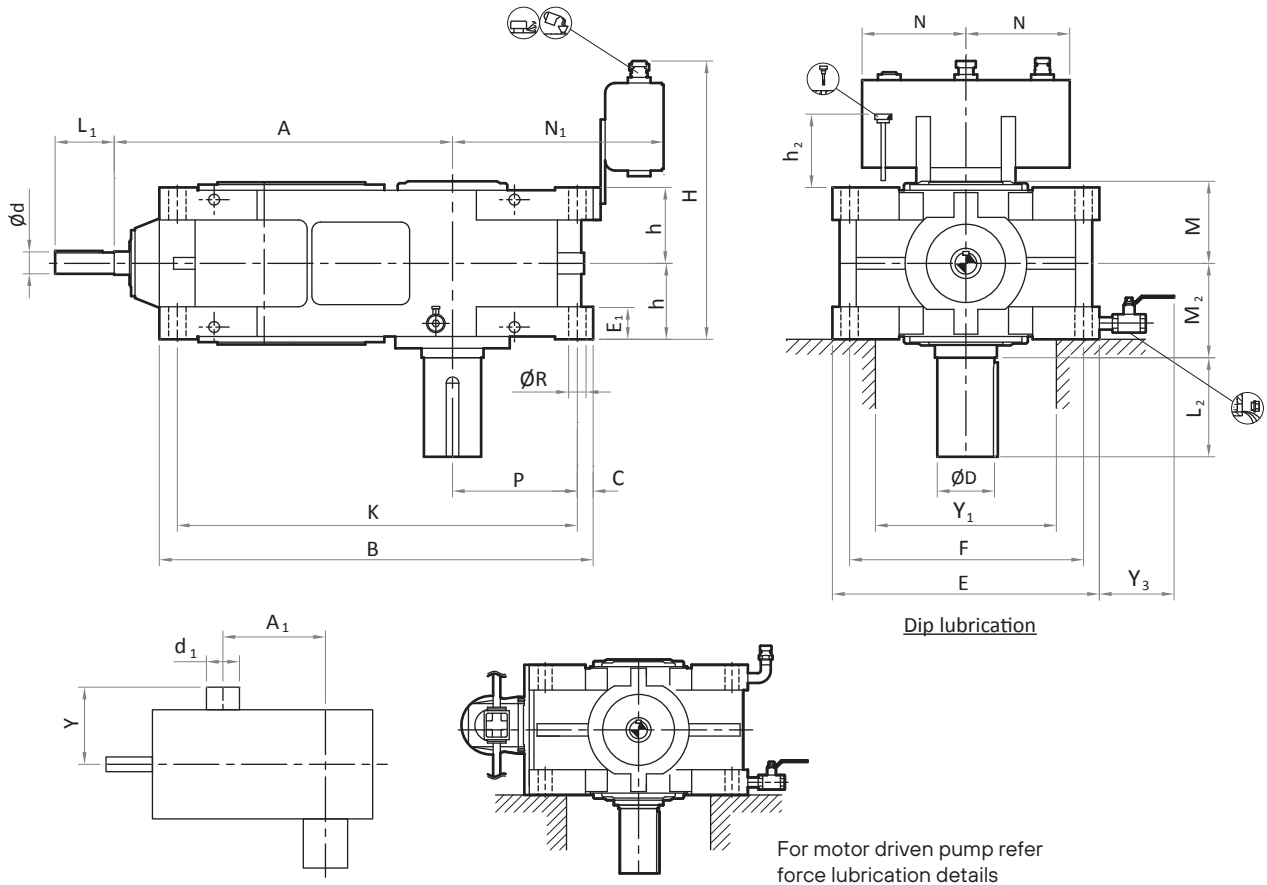

Dip lubrication

For motor driven pump refer force lubrication details

Size	Input Shaft						Output Shaft				Backstop			Weight (Kg) ¹⁾	Oil Quantity (Liters) ¹⁾
	i = 80 - 200		i = 224 - 315		i = 355		D	L ₂	M ₂	M	A ₁	d ₁	Y		
	d	L ₁	d	L ₁	d	L ₁									
720	35	90	32	90	32	90	140	250	240	230	583	140	315	930	101
721	35	90	32	90	32	90	160	300	240	230	632	140	315	1075	106
722	45	110	35	90	35	90	170	300	270	260	716	175	365	1505	164
723	45	110	35	90	35	90	180	340	270	260	777	175	365	1705	177
724	55	120	45	110	35	90	200	340	335	310	833	190	420	2405	294
725	55	120	45	110	35	90	210	350	335	310	898	190	420	2730	302

Size	Foundation															
	A	B	C	E	E ₁	F	h ^{-0.5}	H ¹⁾	h ₂ ¹⁾	K	N	P	R	Y ₁ ¹⁾	Y ₃ ¹⁾	N ₁
720	853	1125	40	640	80	560	200	750	300	1045	300	295	33	420	230	550
721	902	1224	40	640	80	560	200	750	300	1144	300	345	33	420	230	600
722	1041	1355	40	760	100	660	237	820	350	1275	300	360	39	530	230	615
723	1102	1476	40	760	100	660	237	820	350	1396	300	420	39	530	230	675
724	1183	1540	50	880	110	760	280	900	420	1440	300	405	45	610	230	675
725	1248	1670	50	880	110	760	280	900	420	1570	300	470	45	610	230	735

1) Approximate values

Bevel Helical gear units over driven mounting position

5.11 Type B40 - Gear unit dimensions, Four stage, Size 716 to 719

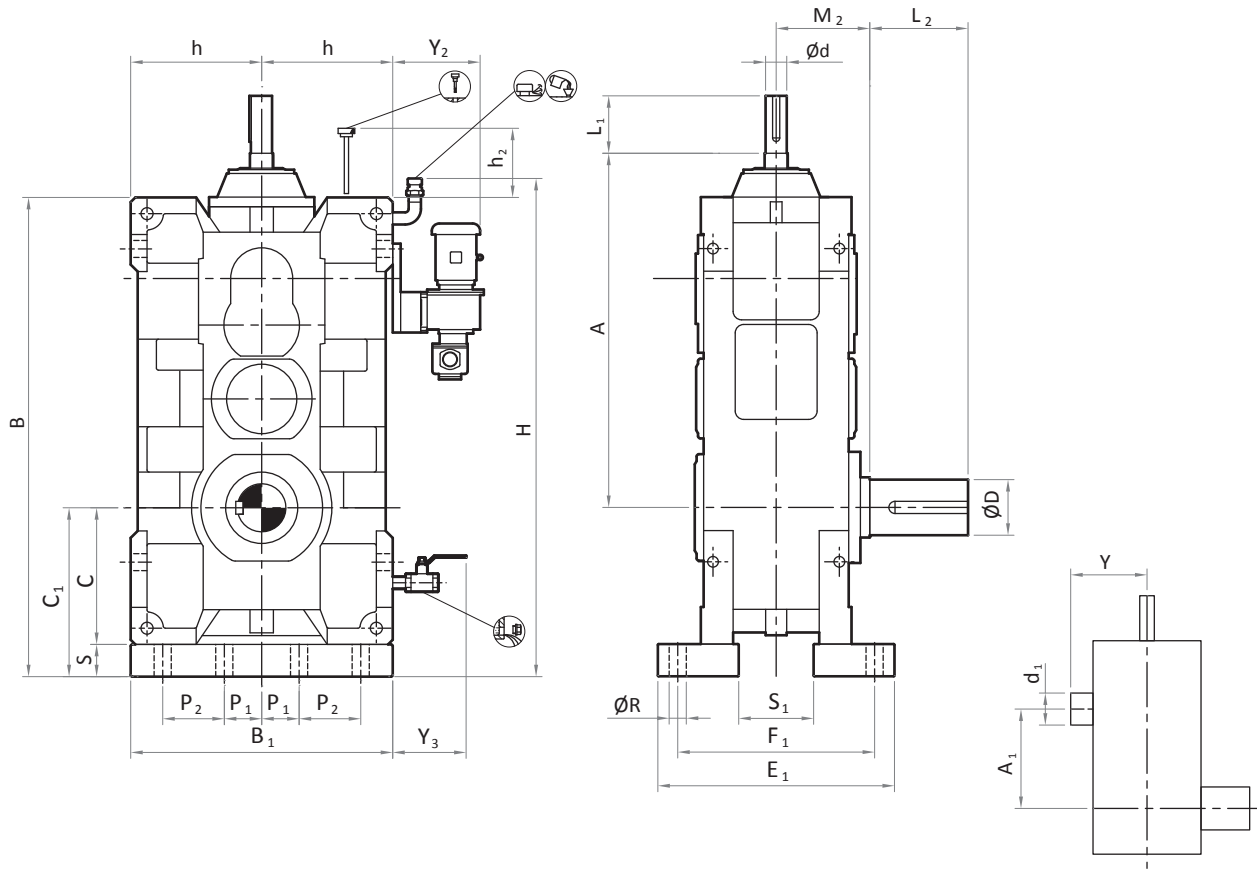

Size	Input Shaft						Output Shaft				Backstop			Weight (Kg) ¹⁾	Oil Quantity (Liters) ¹⁾
	i = 80 - 200		i = 224 - 315		i = 355		D	L ₂	M ₂	M	A ₁	d ₁	Y		
	d	L ₁	d	L ₁	d	L ₁									
716	28	85	20	80	20	80	100	210	170	160	405	95	220	360	17
717	28	85	20	80	20	80	110	210	170	160	442	95	220	410	19
718	30	85	30	85	22	80	120	210	200	185	495	132	255	625	33
719	30	85	30	85	22	80	130	240	200	185	544	132	255	700	34

Size	Foundation																
	A	B	B ₁	C	C ₁ ^{-0.5}	E ₁	F ₁	h ^{-0.5}	H ¹⁾	h ₂ ¹⁾	P ₁	P ₂	R	S	S ₁	Y ₂ ¹⁾	Y ₃ ¹⁾
716	620	835	460	245	275	390	335	230	950	400	90	90	18	30	150	315	180
717	657	912	460	285	315	390	335	230	1025	400	90	90	18	30	150	315	180
718	730	1005	560	295	335	470	410	280	1125	450	100	120	23	40	175	370	180
719	779	1104	560	345	385	470	410	280	1220	450	100	120	23	40	175	370	180

1) Approximate values

Bevel Helical gear units over driven mounting position

5.11 Type B40 - Gear unit dimensions, Four stage, Size 720 to 725

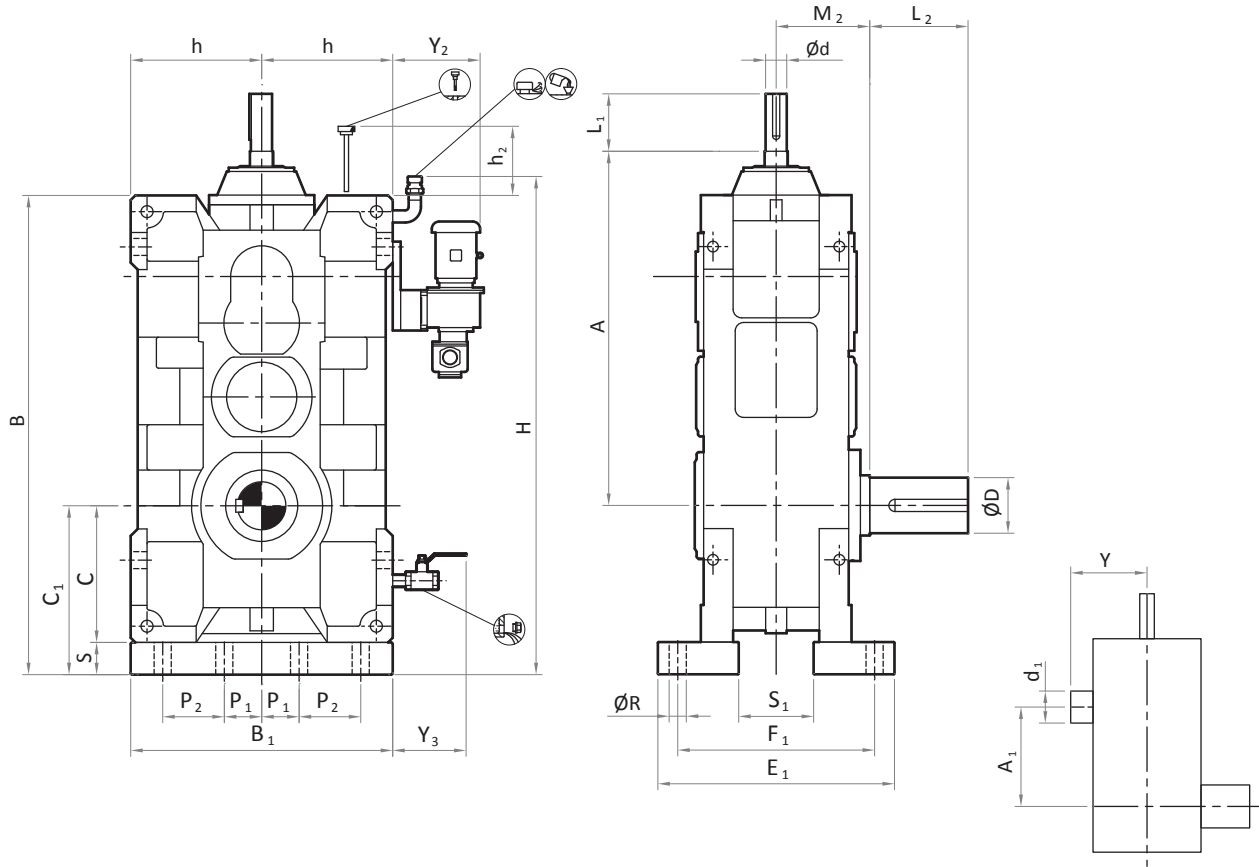

Size	Input Shaft						Output Shaft				Backstop			Weight (Kg) ¹⁾	Oil Quantity (Liters) ¹⁾
	i = 80 - 200		i = 224 - 315		i = 355		D	L ₂	M ₂	M	A ₁	d ₁	Y		
	d	L ₁	d	L ₁	d	L ₁									
720	35	90	32	90	32	90	140	250	240	230	583	140	315	1010	53
721	35	90	32	90	32	90	160	300	240	230	632	140	315	1155	55
722	45	110	35	90	35	90	170	300	270	260	716	175	365	1645	85
723	45	110	35	90	35	90	180	340	270	260	777	175	365	1845	92
724	55	120	45	110	35	90	200	340	335	310	833	190	420	2620	154
725	55	120	45	110	35	90	210	350	335	310	898	190	420	2945	158

Size	Foundation																
	A	B	B ₁	C	C ₁ ^{-0.5}	E ₁	F ₁	h ^{-0.5}	H ¹⁾	h ₂ ¹⁾	P ₁	P ₂	R	S	S ₁	Y ₂ ¹⁾	Y ₃ ¹⁾
720	853	1175	640	335	385	540	470	320	1340	600	120	140	27	50	210	410	230
721	902	1274	640	385	435	540	470	320	1430	600	120	140	27	50	210	410	230
722	1041	1415	760	400	460	650	560	380	1580	700	140	180	33	60	245	470	230
723	1102	1536	760	460	520	650	560	380	1700	700	140	180	33	60	245	470	230
724	1183	1610	880	455	525	760	660	440	1770	700	170	200	39	70	300	530	230
725	1248	1740	880	520	590	760	660	440	1900	700	170	200	39	70	300	530	230

1) Approximate values

Bevel Helical gear units

5.12 Type B4 – Gear unit shaft arrangement views

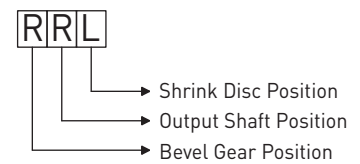
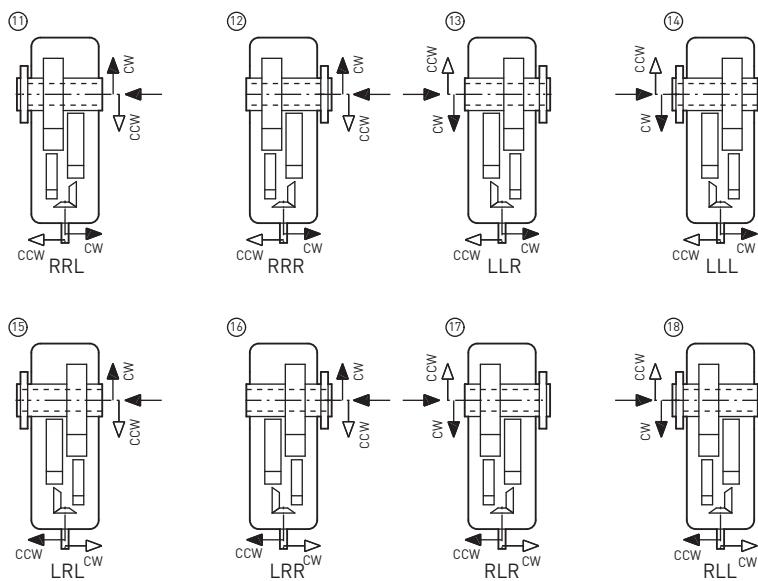
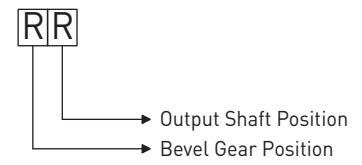
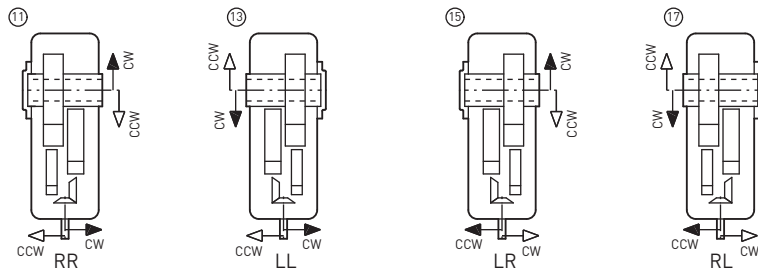
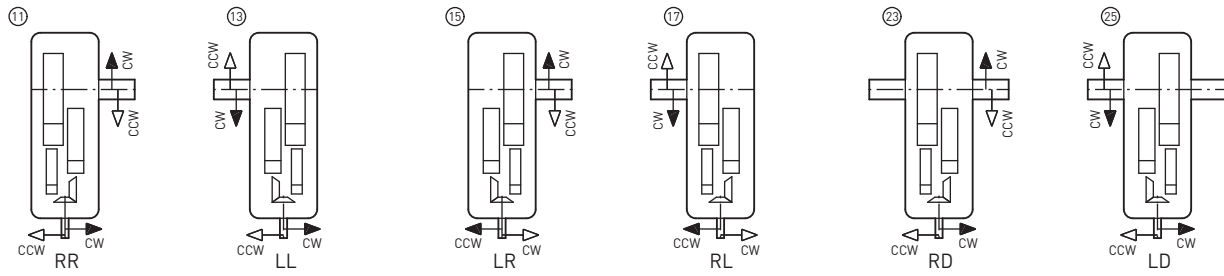

Intermediate Extension

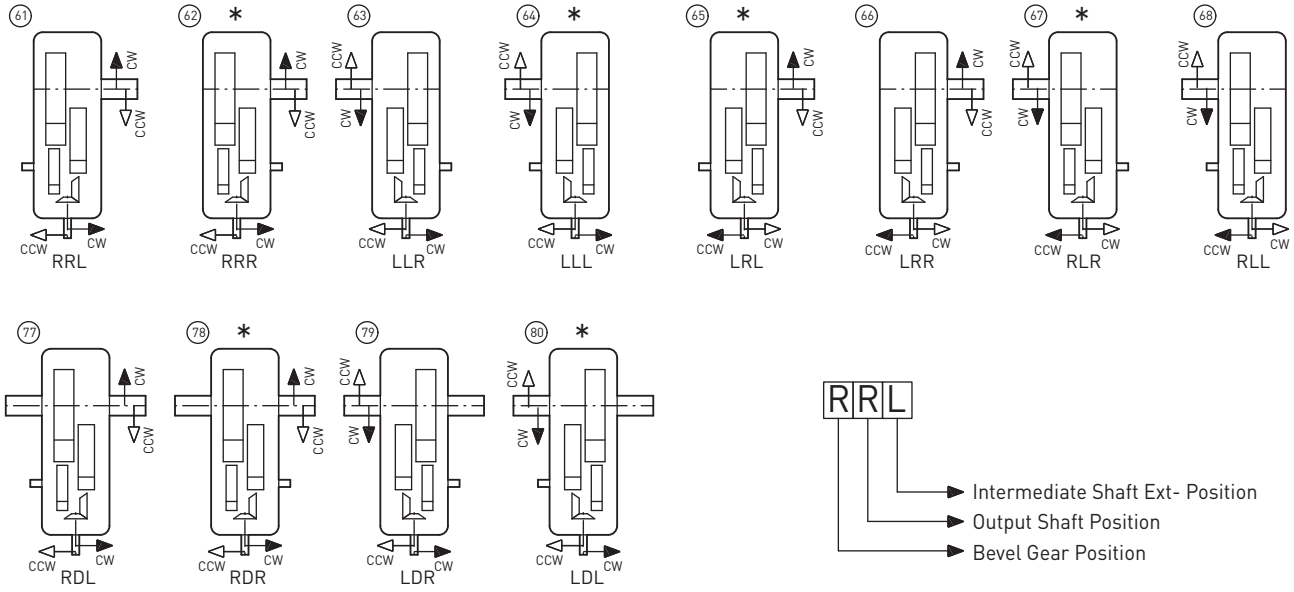

Intermediate Extension

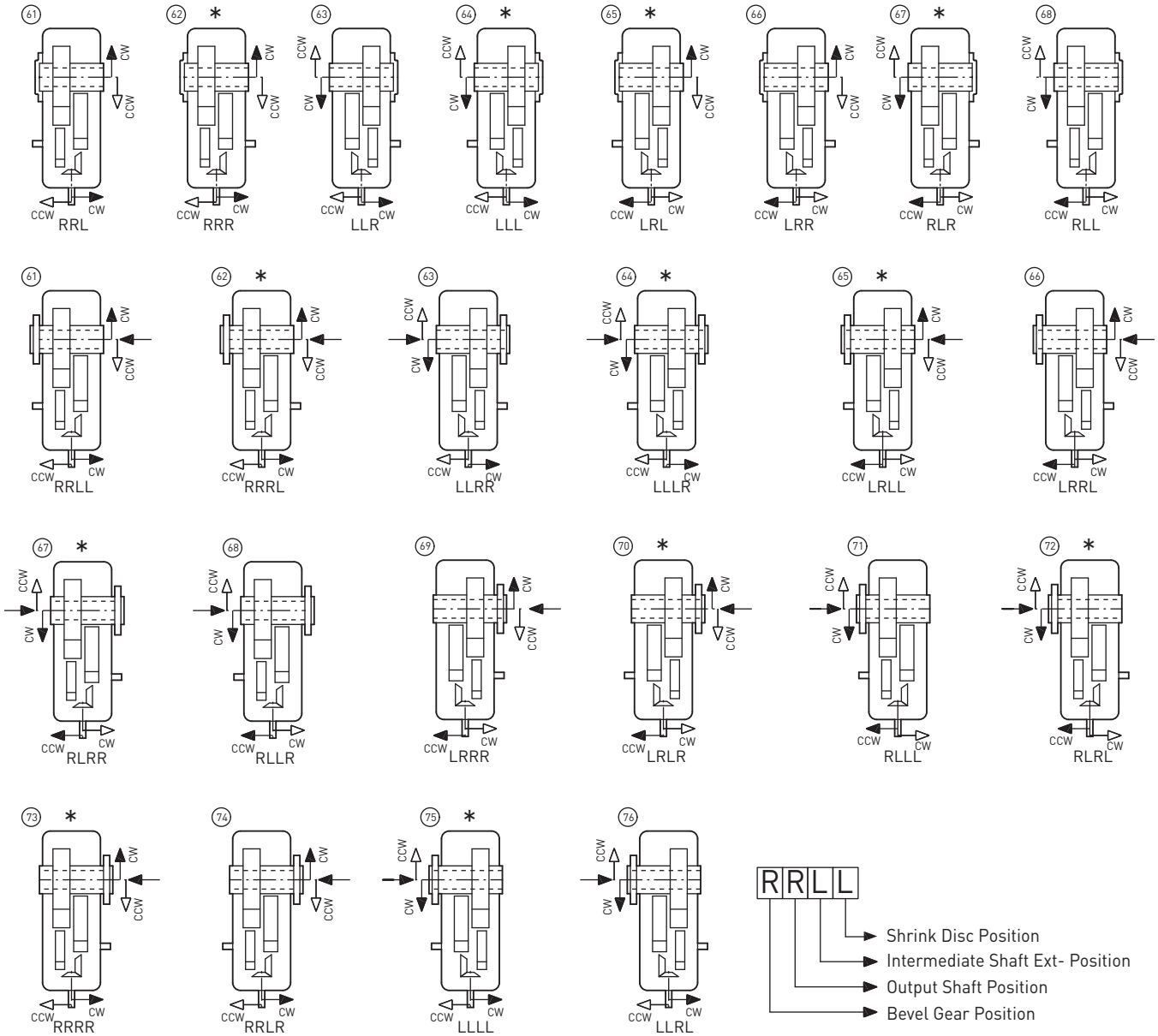

Holdback

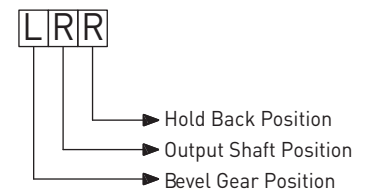
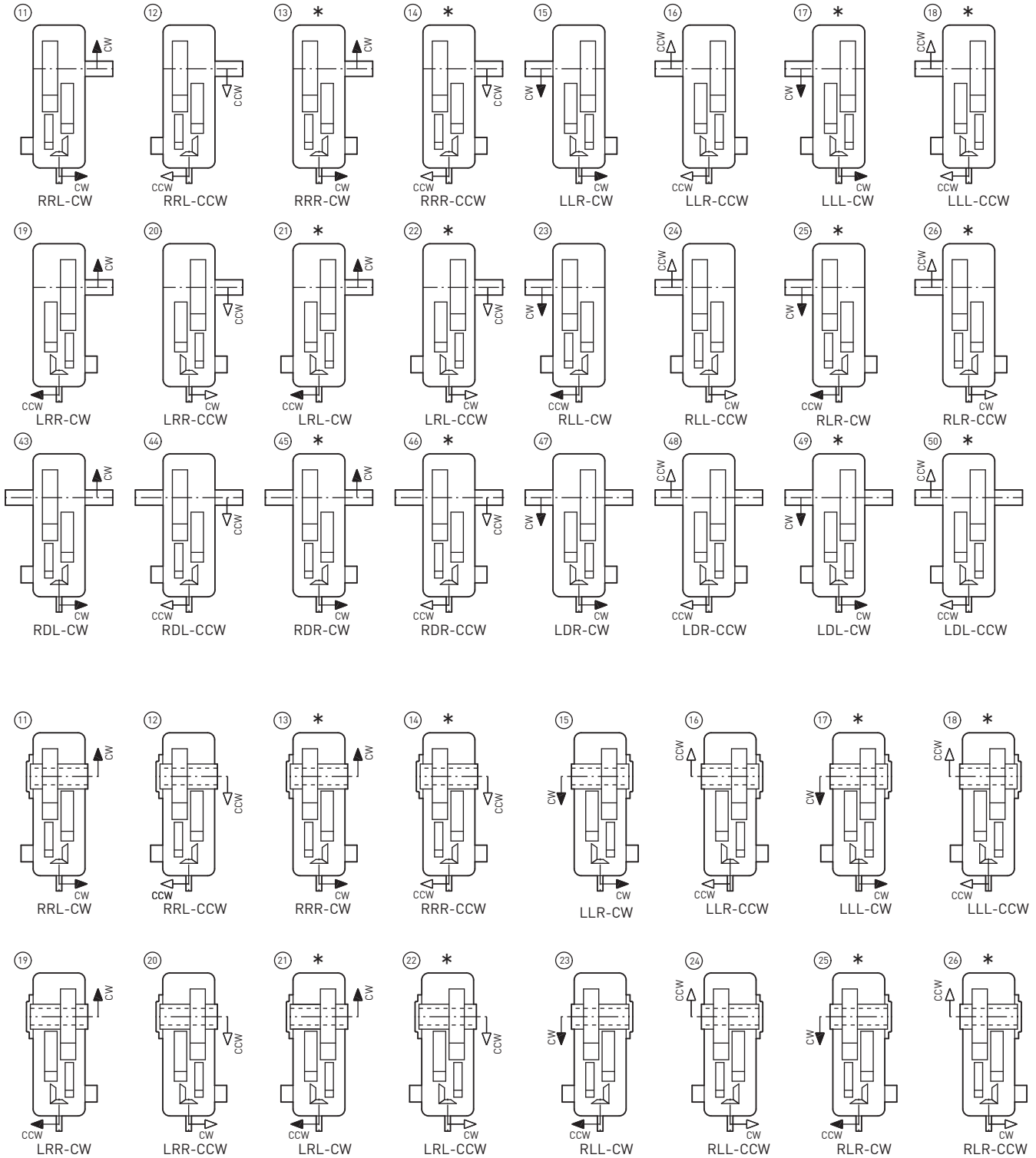

Holdback

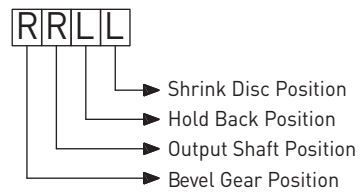
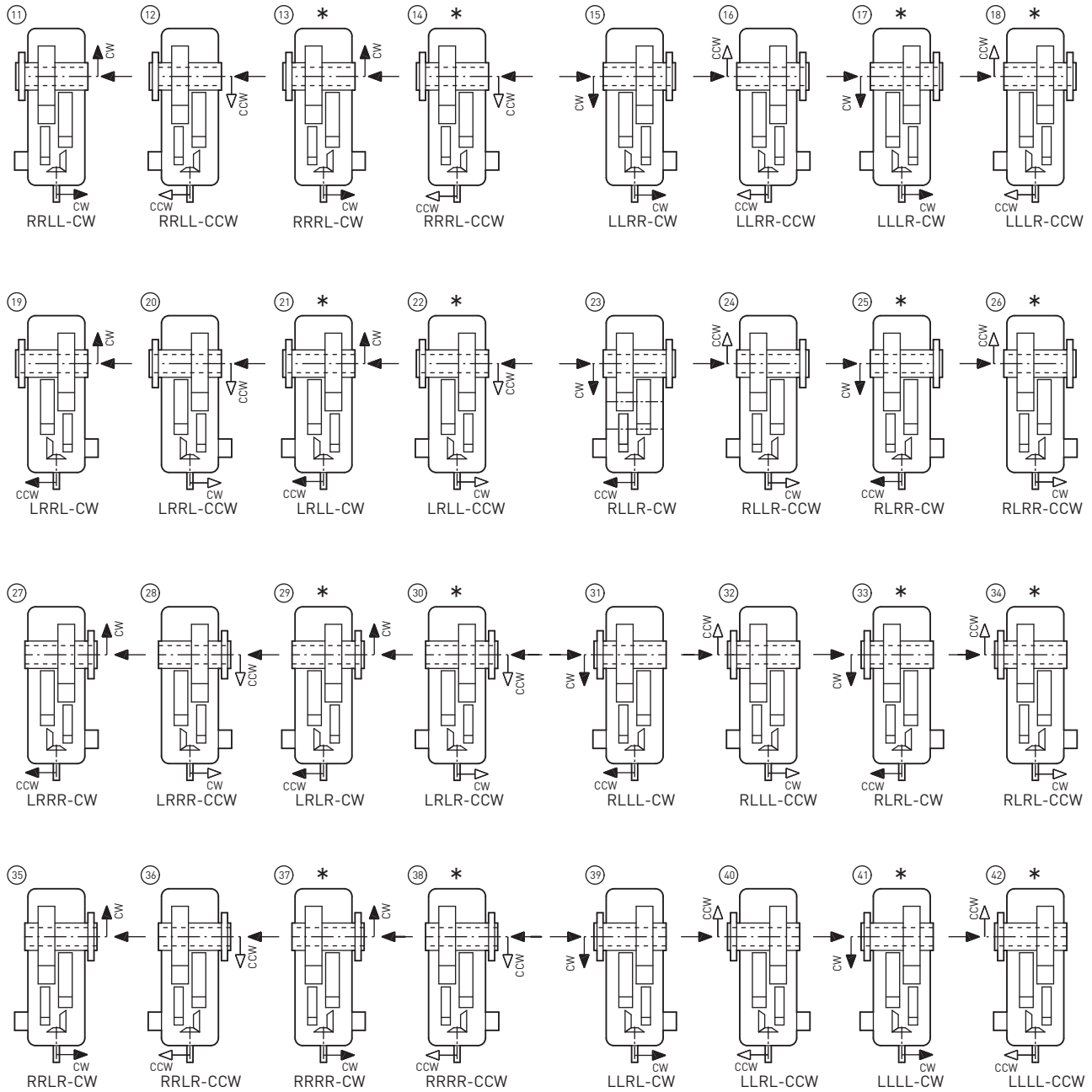

Intermediate Extension & Holdback

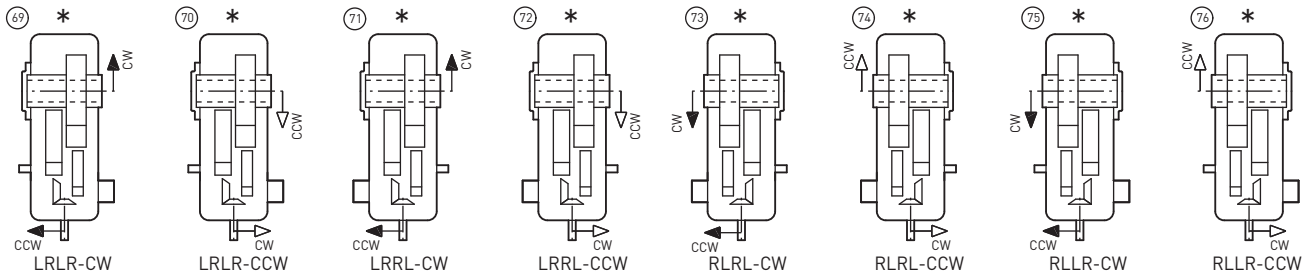
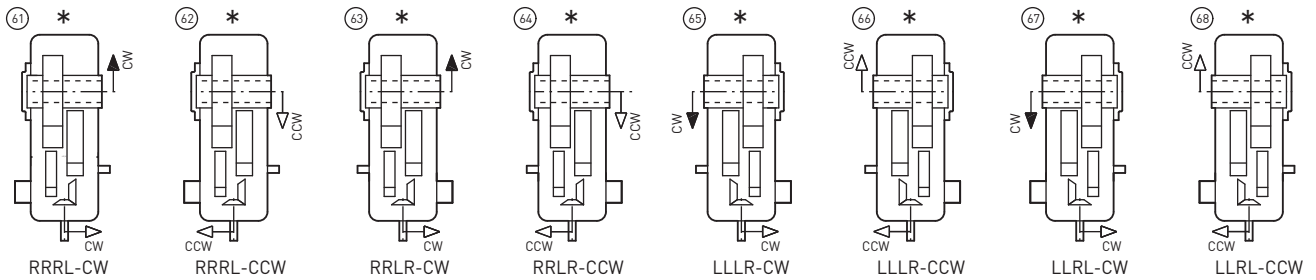
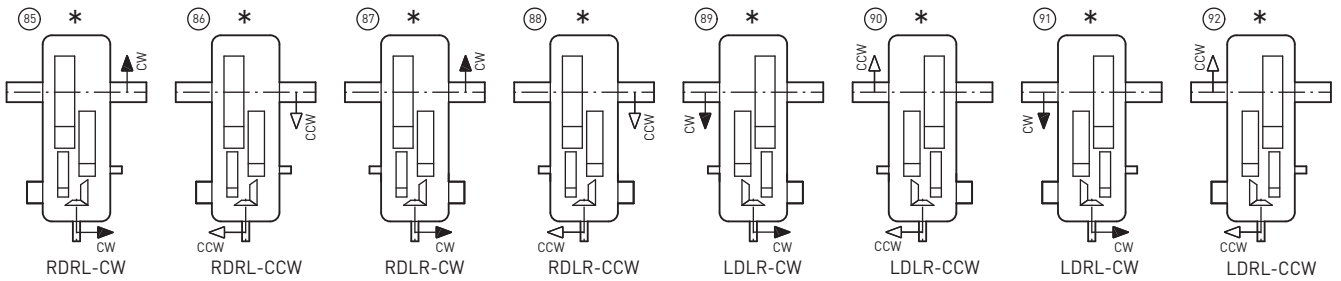
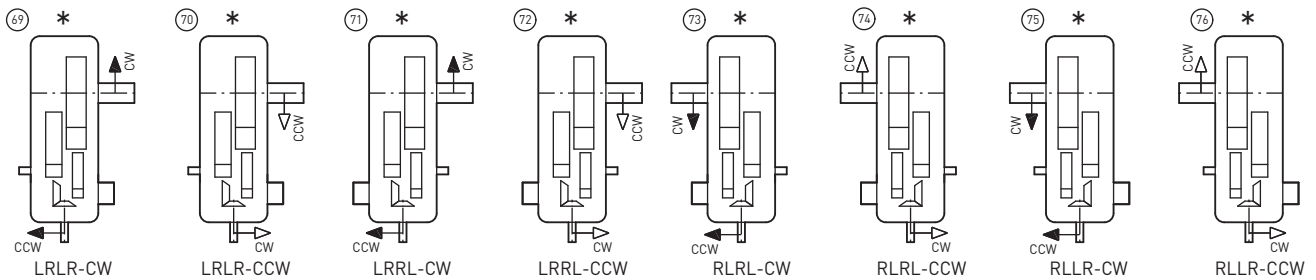
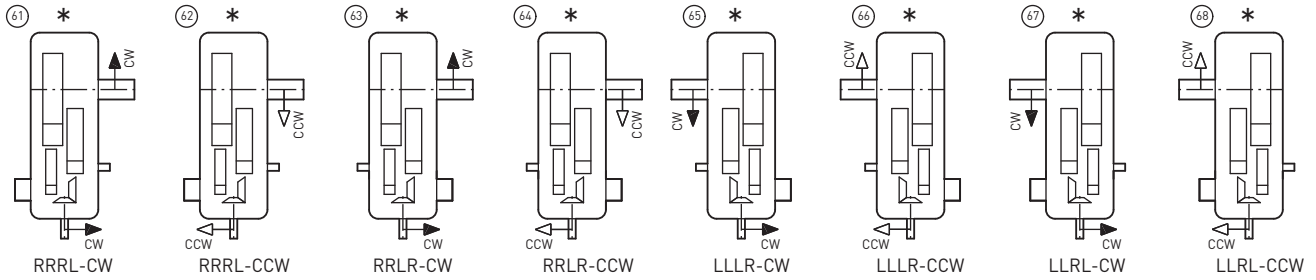

Intermediate Extension & Holdback

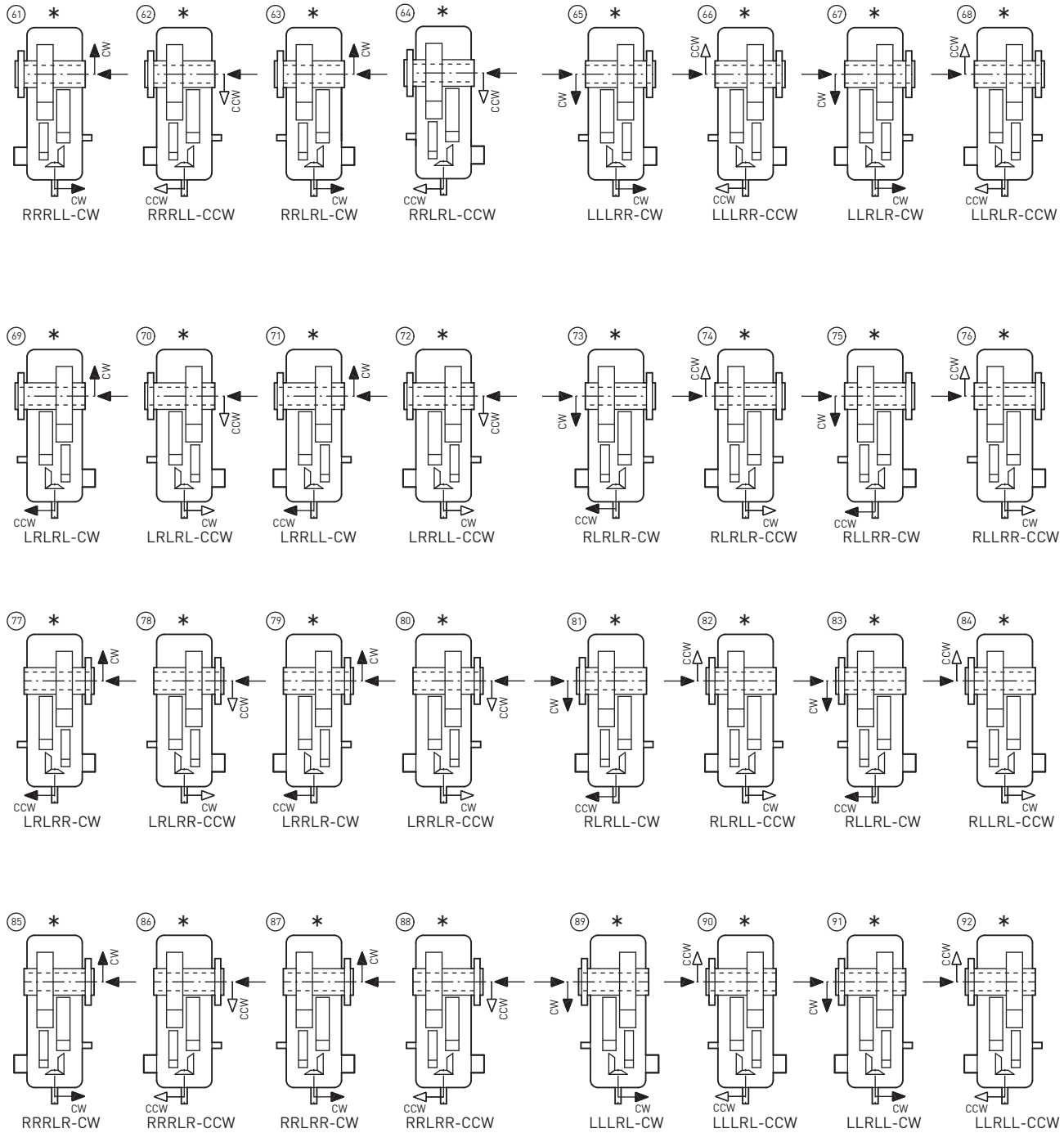

LRLRR

- Shrink Disc Position
- Hold Back Position
- Intermediate Shaft Ext- Position
- Output Shaft Position
- Bevel Gear Position



COMPACT DRIVE GEAR UNITS

- 6.1 Type C3H – Gear unit dimensions
- 6.2 Type C3V – Gear unit dimensions
- 6.3 Type C3O – Gear unit dimensions
- 6.4 Type C3U – Gear unit dimensions
- 6.5 Type C3 – Gear unit shaft
arrangement views
- 6.6 Type C4H – Gear unit dimensions
- 6.7 Type C4V – Gear unit dimensions
- 6.8 Type C4O – Gear unit dimensions
- 6.9 Type C4U – Gear unit dimensions
- 6.10 Type C4 – Gear unit shaft
arrangement views

Compact Bevel Helical gear units horizontal mounting position

6.1 Type C3H - Gear unit dimensions, Three stage, Size 714 to 719

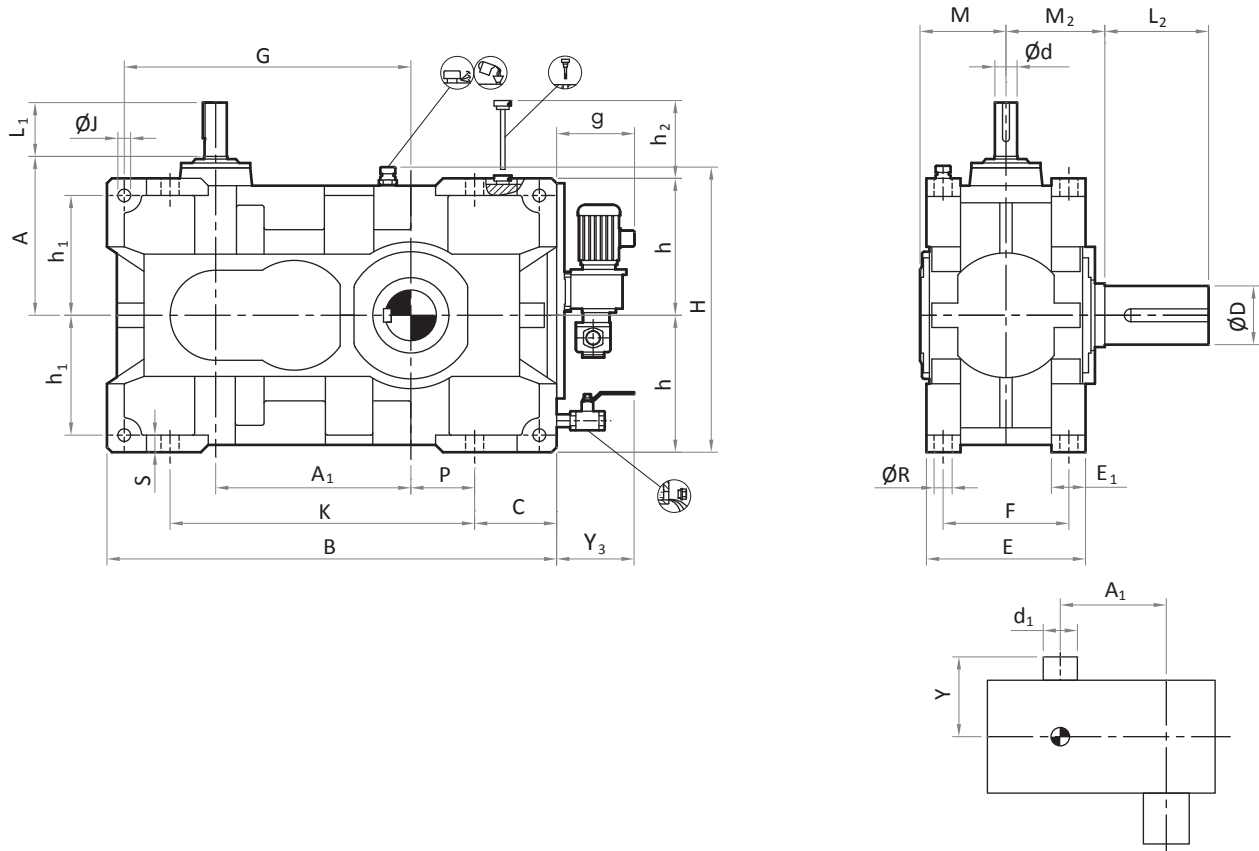

Size	Input Shaft				Mounting Dimensions	Output Shaft					Backstop			Weight (Kg) ¹⁾	Oil Quantity (Liters) ¹⁾
	i = 12.5 - 50		i = 56 - 71			A	D	L ₂	M ₂	M	A ₁	d ₁	Y		
	i = 16 - 63		i = 71 - 90												
	d	L ₁	d	L ₁		D	L ₂	M ₂	M	A ₁	d ₁	Y			
714	30	85	30	85	235	60	120	150	135	232	132	215	170	7	
715	30	85	30	85	235	80	160	150	135	259	132	215	205	8	
716	35	90	32	90	270	100	210	170	160	315	150	245	320	14	
717	35	90	32	90	270	110	210	170	160	352	150	245	365	15	
718	45	110	35	90	325	120	210	200	185	395	190	290	545	26	
719	45	110	35	90	325	130	240	200	185	444	190	290	630	29	

Size	Foundation																	
	A ₁	B	C	E	E ₁	F	G	h ^{-0.5}	h ₁	H ¹⁾	h ₂ ¹⁾	J	K	P	R	S	Y ₃ ¹⁾	g ¹⁾
714	232	570	95	250	56	200	371	200	176	450	300	23	380	80	18	24	150	350
715	259	632	95	250	56	200	398	200	176	450	300	23	445	115	18	24	150	350
716	315	750	145	270	55	224	475	230	200	510	405	23	500	100	18	28	180	350
717	352	827	145	270	55	224	512	230	200	510	405	23	580	140	18	28	180	350
718	395	910	165	322	69	270	580	280	245	610	415	27	630	130	23	35	180	350
719	444	1009	165	322	69	270	629	280	245	610	415	27	720	180	23	35	180	350

1) Approximate values

Compact Bevel Helical gear units horizontal mounting position

6.1 Type C3H - Gear unit dimensions, Three stage, Size 720 to 725

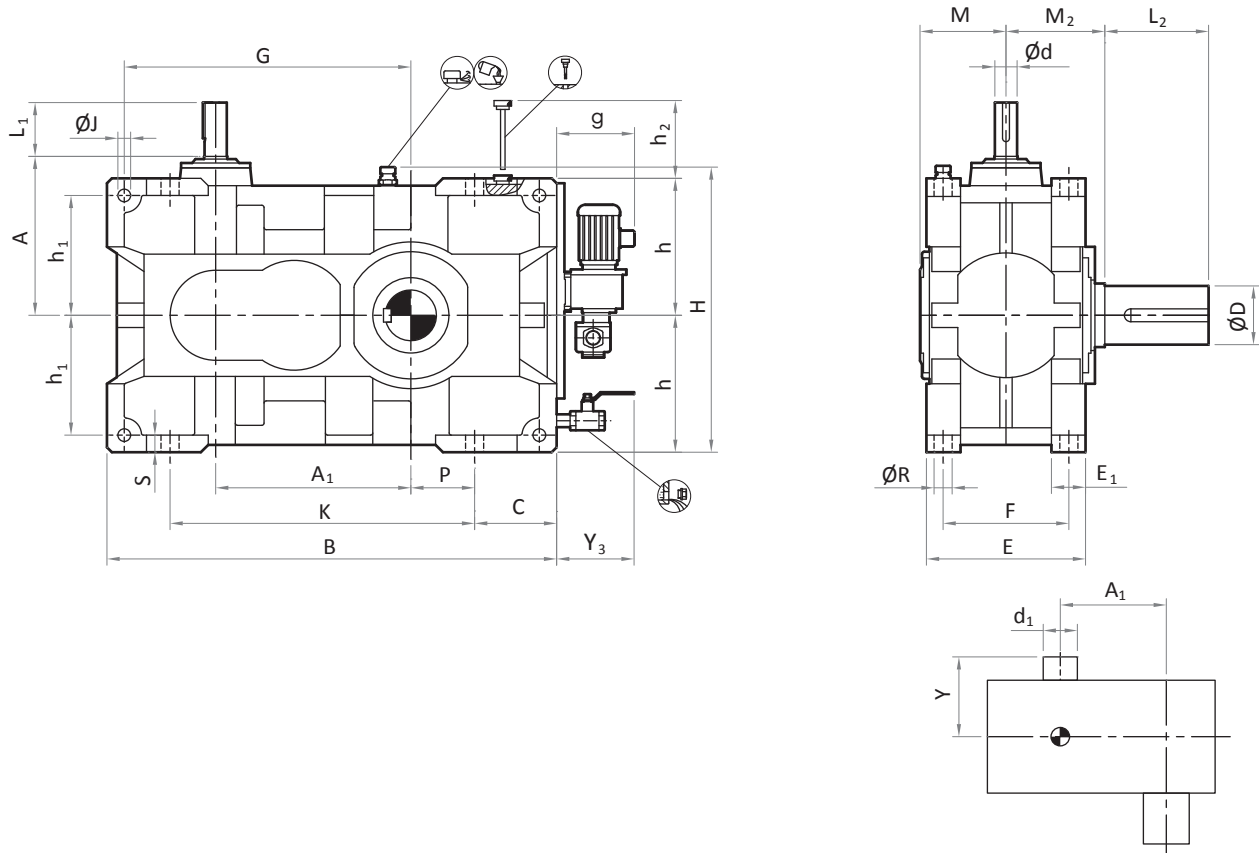

Size	Input Shaft				Mounting Dimensions	Output Shaft					Backstop			Weight (Kg) ¹⁾	Oil Quantity (Liters) ¹⁾
	i = 12.5 - 50		i = 56 - 71			D	L ₂	M ₂	M	A ₁	d ₁	Y			
	d	L ₁	d	L ₁											
720	55	120	45	110	350	140	250	240	230	453	210	350	900	42	
721	55	120	45	110	350	160	300	240	230	502	210	350	1045	45	
722	70	150	55	120	425	170	300	270	260	556	245	395	1500	72	
723	70	150	55	120	425	180	340	270	260	617	245	395	1705	74	
724	80	160	60	130	490	200	340	335	310	647	290	470	2360	132	
725	80	160	60	130	490	210	350	335	310	712	290	470	2680	133	

Size	Foundation																	
	A ₁	B	C	E	E ₁	F	G	h ^{-0.5}	h ₁	H ¹⁾	h ₂ ¹⁾	J	K	P	R	S	Y ₃ ¹⁾	g ¹⁾
720	453	1045	175	400	80	340	670	320	280	690	500	33	730	160	27	40	250	350
721	502	1144	175	400	80	340	719	320	280	690	500	33	830	210	27	40	250	350
722	556	1260	210	474	100	400	810	380	330	810	650	39	900	190	33	50	225	350
723	617	1381	210	474	100	400	871	380	330	810	650	39	1010	250	33	50	225	350
724	647	1455	220	560	110	475	950	440	380	930	700	45	1055	235	39	60	225	350
725	712	1585	220	560	110	475	1015	440	380	930	700	45	1190	300	39	60	225	350

1) Approximate values

Compact Bevel Helical gear units vertical mounting position

6.2 Type C3V - Gear unit dimensions, Three stage, Size 714 to 719

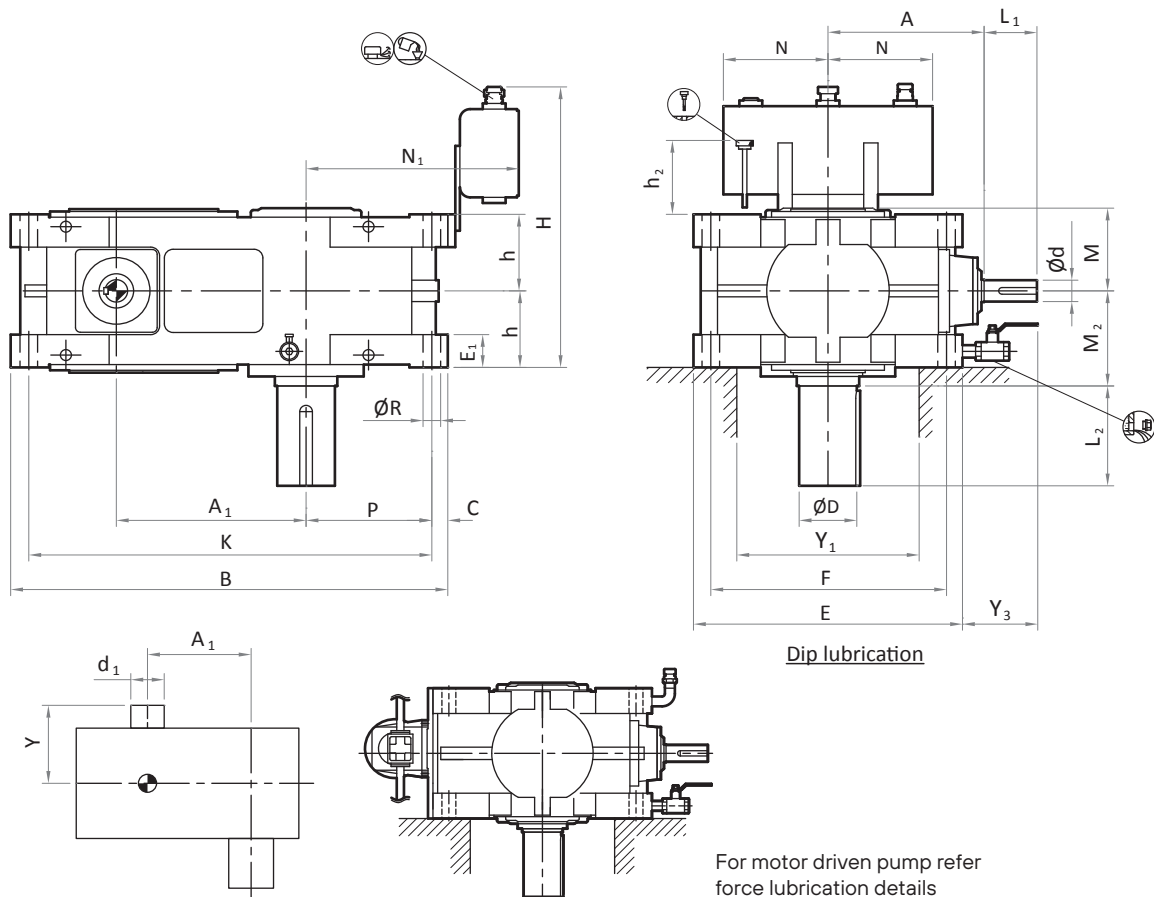

Size	Input Shaft				Mounting Dimensions	Output Shaft					Backstop			Weight (Kg) ¹⁾	Oil Quantity (Liters) ¹⁾
	i = 12.5 - 50		i = 56 - 71			A	D	L ₂	M ₂	M	A ₁	d ₁	Y		
	i = 16 - 63		i = 71 - 90												
	d	L ₁	d	L ₁		D	L ₂	M ₂	M	A ₁	d ₁	Y			
714	30	85	30	85	235	60	120	150	135	232	132	215	170	14	
715	30	85	30	85	235	80	160	150	135	259	132	215	205	17	
716	35	90	32	90	270	100	210	170	160	315	150	245	320	30	
717	35	90	32	90	270	110	210	170	160	352	150	245	365	31	
718	45	110	35	90	325	120	210	200	185	395	190	290	545	54	
719	45	110	35	90	325	130	240	200	185	444	190	290	630	60	

Size	Foundation															
	A ₁	B	C	E	E ₁	F	h ^{-0.5}	H ¹⁾	h ₂ ¹⁾	K	N	P	R	Y ₁ ¹⁾	Y ₃ ¹⁾	N ₁
714	232	570	24	400	56	352	125	480	185	522	190	151	23	275	160	325
715	259	632	24	400	56	352	125	480	185	584	190	186	23	275	160	360
716	315	750	30	460	55	400	135	500	200	690	190	215	23	280	180	395
717	352	827	30	460	55	400	135	500	200	767	190	255	23	280	180	435
718	395	910	35	560	69	490	161	550	240	840	190	260	27	350	180	445
719	444	1009	35	560	69	490	161	550	240	939	190	310	27	350	180	495

1) Approximate values

Compact Bevel Helical gear units vertical mounting position

6.2 Type C3V - Gear unit dimensions, Three stage, Size 720 to 725

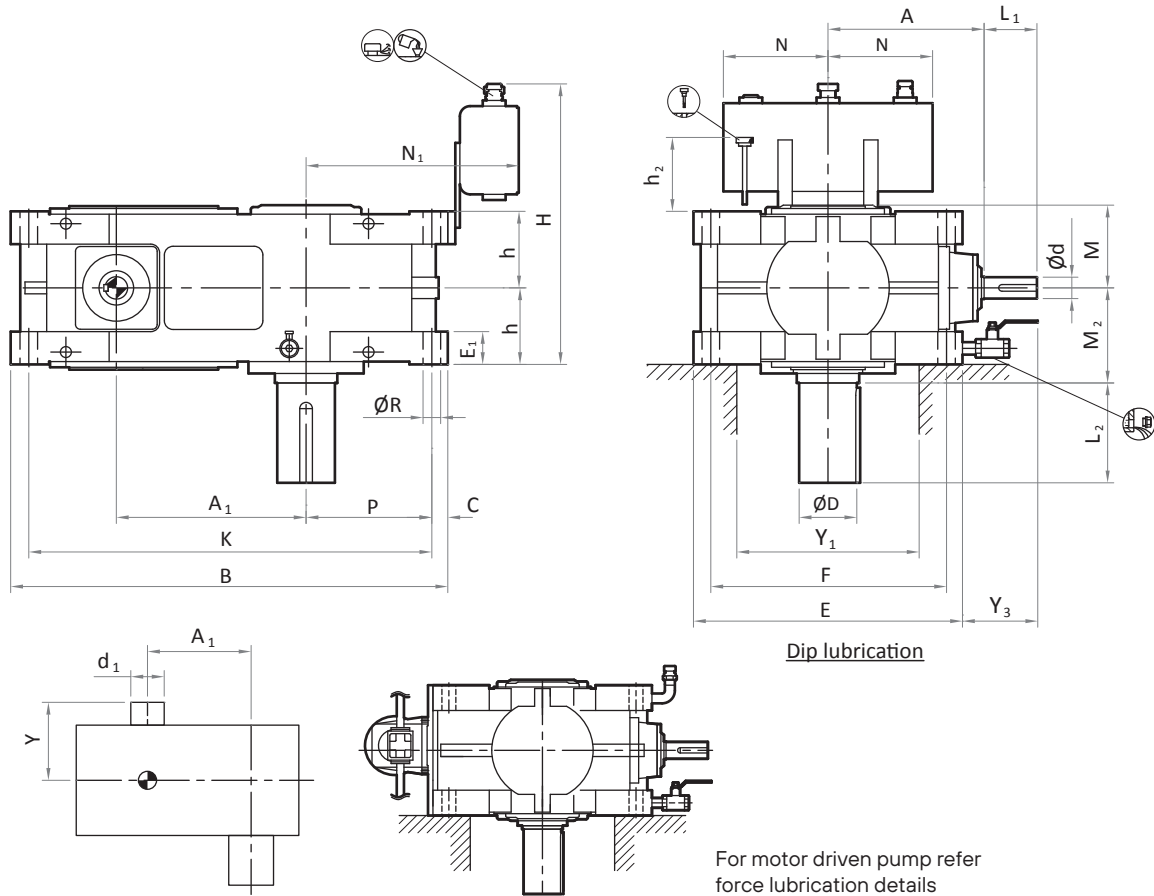

Size	Input Shaft				Mounting Dimensions	Output Shaft					Backstop			Weight (Kg) ¹⁾	Oil Quantity (Liters) ¹⁾
	i = 12.5 - 50		i = 56 - 71			D	L ₂	M ₂	M	A ₁	d ₁	Y			
	i = 16 - 63		i = 71 - 90												
	d	L ₁	d	L ₁		A									
720	55	120	45	110	350	140	250	240	230	453	210	350	900	86	
721	55	120	45	110	350	160	300	240	230	502	210	350	1045	93	
722	70	150	55	120	425	170	300	270	260	556	245	395	1500	148	
723	70	150	55	120	425	180	340	270	260	617	245	395	1705	151	
724	80	160	60	130	490	200	340	335	310	647	290	470	2360	270	
725	80	160	60	130	490	210	350	335	310	712	290	470	2680	275	

Size	Foundation															
	A ₁	B	C	E	E ₁	F	h ^{-0.5}	H ¹⁾	h ₂ ¹⁾	K	N	P	R	Y ₁ ¹⁾	Y ₃ ¹⁾	N ₁
720	453	1045	40	640	80	560	200	750	300	965	300	295	33	420	230	550
721	502	1144	40	640	80	560	200	750	300	1064	300	345	33	420	230	600
722	556	1260	50	760	100	660	237	820	350	1160	300	360	39	530	230	615
723	617	1381	50	760	100	660	237	820	350	1281	300	420	39	530	230	675
724	647	1455	50	880	110	760	280	900	420	1355	300	405	45	610	230	675
725	712	1585	50	880	110	760	280	900	420	1485	300	470	45	610	230	735

1) Approximate values

Compact Bevel Helical gear units over driven mounting position

6.3 Type C30 - Gear unit dimensions, Three stage, Size 714 to 719

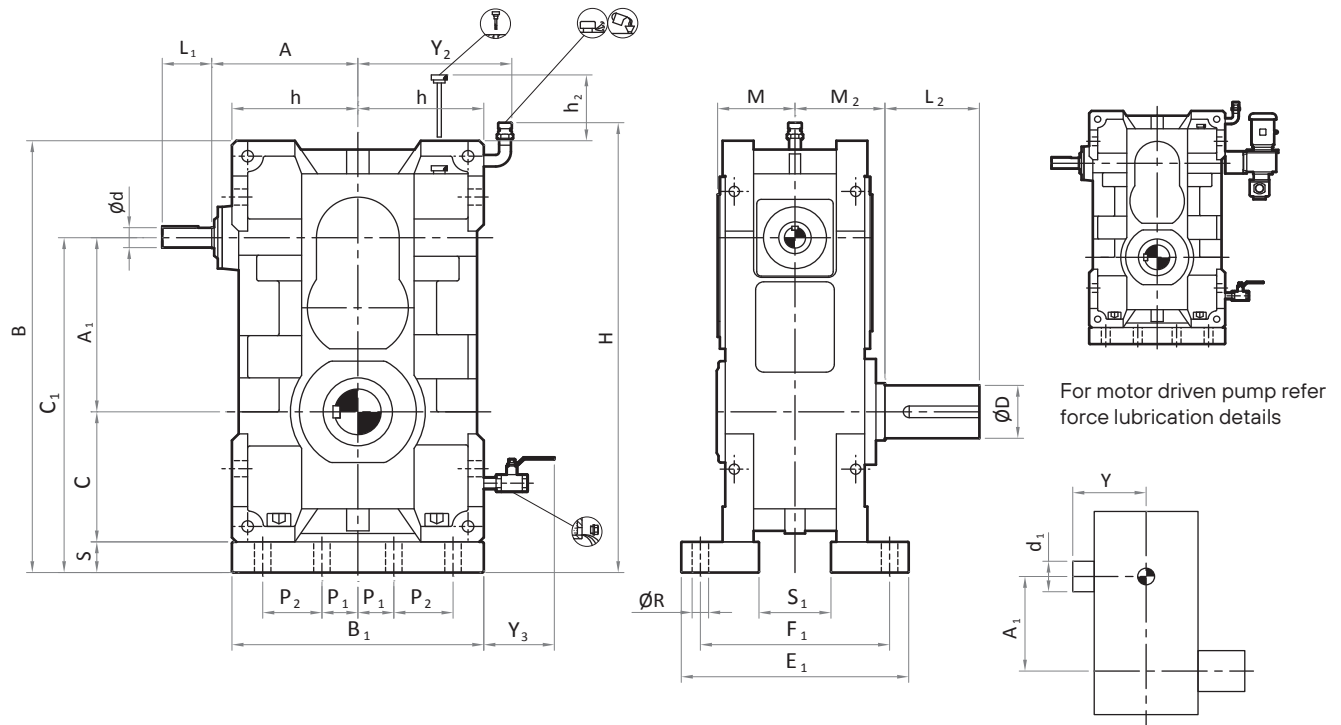

Size	Input Shaft				Mounting Dimensions	Output Shaft					Backstop			Weight (Kg) ¹⁾	Oil Quantity (Liters) ¹⁾
	i = 12.5 - 50		i = 56 - 71			D	L ₂	M ₂	M	A ₁	d ₁	Y			
	i = 16 - 63		i = 71 - 90												
	d	L ₁	d	L ₁		A									
714	30	85	30	85	235	60	120	150	135	232	132	215	190	12	
715	30	85	30	85	235	80	160	150	135	259	132	215	225	13	
716	35	90	32	90	270	100	210	170	160	315	150	245	345	21	
717	35	90	32	90	270	110	210	170	160	352	150	245	390	21	
718	45	110	35	90	325	120	210	200	185	395	190	290	595	38	
719	45	110	35	90	325	130	240	200	185	444	190	290	680	42	

Size	Foundation																
	A ₁	B	B ₁	C	C ₁ ^{-0.5}	E ₁	F ₁	h ^{-0.5}	H ¹⁾	h ₂ ¹⁾	P ₁	P ₂	R	S	S ₁	Y ₂ ¹⁾	Y ₃ ¹⁾
714	232	600	400	175	437	340	295	200	690	350	70	80	18	30	120	250	160
715	259	662	400	210	499	340	295	200	750	350	70	80	18	30	120	250	160
716	315	780	460	245	590	390	335	230	875	400	90	90	18	30	150	315	180
717	352	857	460	285	667	390	335	230	950	400	90	90	18	30	150	315	180
718	395	950	560	295	730	470	410	280	1050	450	100	120	23	40	175	370	180
719	444	1049	560	345	829	470	410	280	1150	450	100	120	23	40	175	370	180

1) Approximate values

Compact Bevel Helical gear units over driven mounting position

6.3 Type C30 - Gear unit dimensions, Three stage, Size 720 to 725

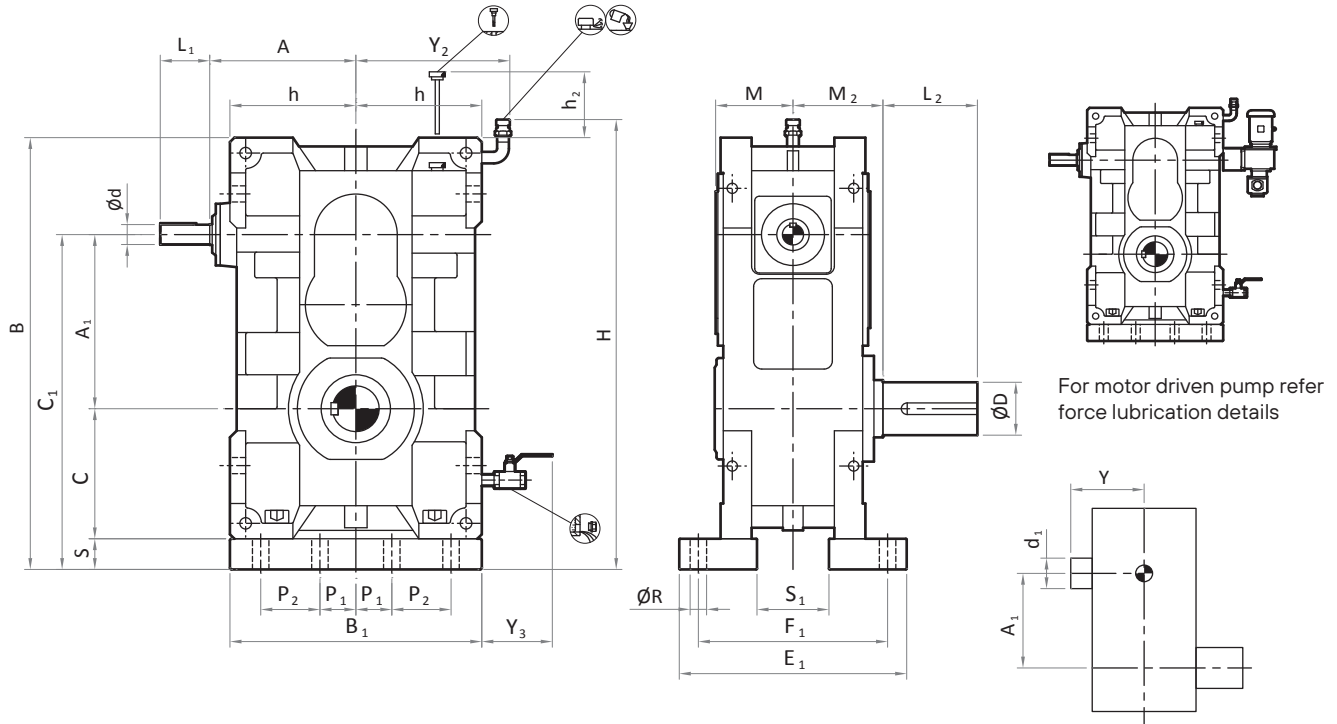

Size	Input Shaft				Mounting Dimensions	Output Shaft					Backstop			Weight (Kg) ¹⁾	Oil Quantity (Liters) ¹⁾
	i = 12.5 - 50		i = 56 - 71			A	D	L ₂	M ₂	M	A ₁	d ₁	Y		
	i = 16 - 63		i = 71 - 90												
	d	L ₁	d	L ₁											
720	55	120	45	110	350	140	250	240	230	453	210	350	980	60	
721	55	120	45	110	350	160	300	240	230	502	210	350	1125	65	
722	70	150	55	120	425	170	300	270	260	556	245	395	1640	103	
723	70	150	55	120	425	180	340	270	260	617	245	395	1845	105	
724	80	160	60	130	490	200	340	335	310	647	290	470	2575	188	
725	80	160	60	130	490	210	350	335	310	712	290	470	2895	191	

Size	Foundation																
	A ₁	B	B ₁	C	C ₁ ^{-0.5}	E ₁	F ₁	h ^{-0.5}	H ¹⁾	h ₂ ¹⁾	P ₁	P ₂	R	S	S ₁	Y ₂ ¹⁾	Y ₃ ¹⁾
720	453	1095	640	335	838	540	470	320	1230	600	120	140	27	50	210	410	230
721	502	1194	640	385	937	540	470	320	1330	600	120	140	27	50	210	410	230
722	556	1320	760	400	1016	650	560	380	1450	700	140	180	33	60	245	470	230
723	617	1441	760	460	1137	650	560	380	1580	700	140	180	33	60	245	470	230
724	647	1525	880	455	1172	760	660	440	1650	700	170	200	39	70	300	530	230
725	712	1655	880	520	1302	760	660	440	1780	700	170	200	39	70	300	530	230

1) Approximate values

Compact Bevel Helical gear units under driven mounting position

6.4 Type C3U - Gear unit dimensions, Three stage, Size 714 to 719

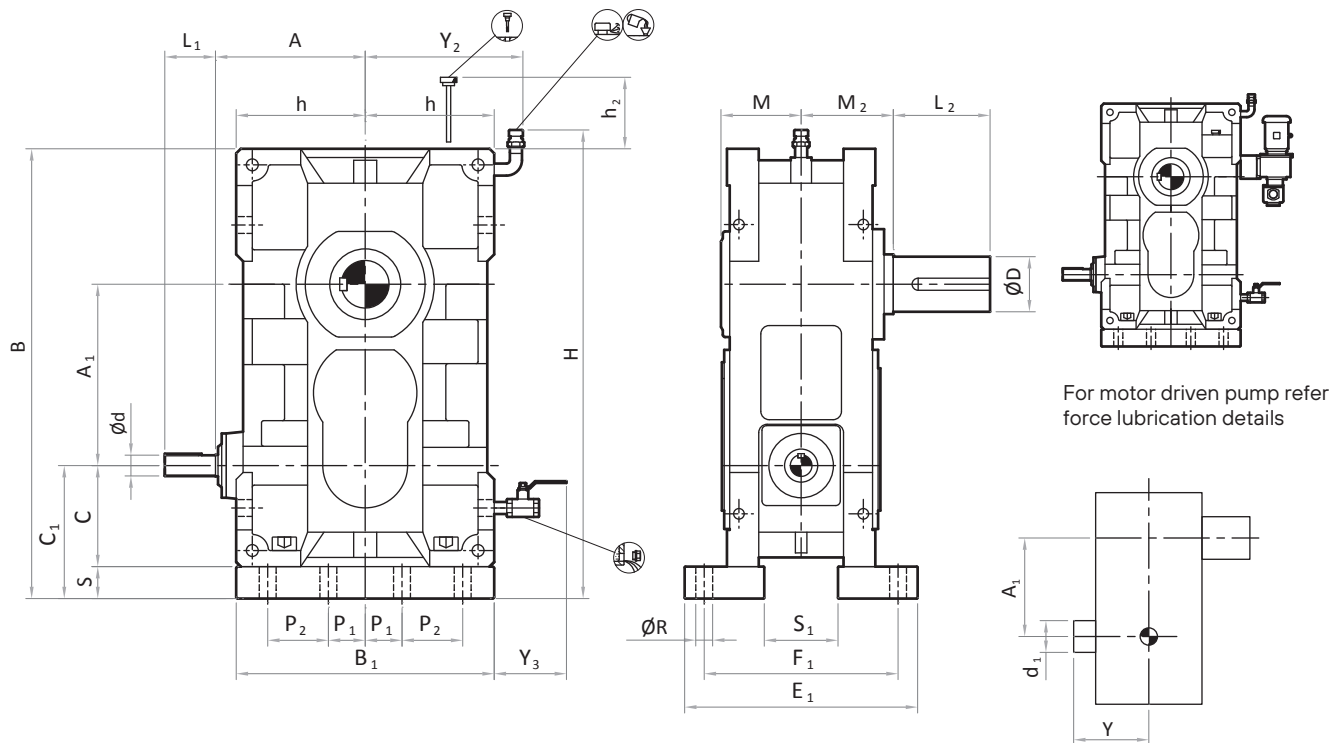

Size	Input Shaft				Mounting Dimensions	Output Shaft					Backstop			Weight (Kg) ¹⁾	Oil Quantity (Liters) ¹⁾
	i = 12.5 - 50		i = 56 - 71			D	L ₂	M ₂	M	A ₁	d ₁	Y			
	i = 16 - 63		i = 71 - 90												
	d	L ₁	d	L ₁		A									
714	30	85	30	85	235	60	120	150	135	232	132	215	190	12	
715	30	85	30	85	235	80	160	150	135	259	132	215	225	13	
716	35	90	32	90	270	100	210	170	160	315	150	245	345	21	
717	35	90	32	90	270	110	210	170	160	352	150	245	390	21	
718	45	110	35	90	325	120	210	200	185	395	190	290	595	38	
719	45	110	35	90	325	130	240	200	185	444	190	290	680	42	

Size	Foundation																
	A ₁	B	B ₁	C	C ₁ ^{-0.5}	E ₁	F ₁	h ^{-0.5}	H ¹⁾	h ₂ ¹⁾	P ₁	P ₂	R	S	S ₁	Y ₂ ¹⁾	Y ₃ ¹⁾
714	232	600	400	163	193	340	295	200	690	350	70	80	18	30	120	250	160
715	259	662	400	163	193	340	295	200	750	350	70	80	18	30	120	250	160
716	315	780	460	190	220	390	335	230	875	400	90	90	18	30	150	315	180
717	352	857	460	190	220	390	335	230	950	400	90	90	18	30	150	315	180
718	395	950	560	220	260	470	410	280	1050	450	100	120	23	40	175	370	180
719	444	1049	560	220	260	470	410	280	1150	450	100	120	23	40	175	370	180

1) Approximate values

Compact Bevel Helical gear units under driven mounting position

6.4 Type C3U - Gear unit dimensions, Three stage, Size 720 to 725

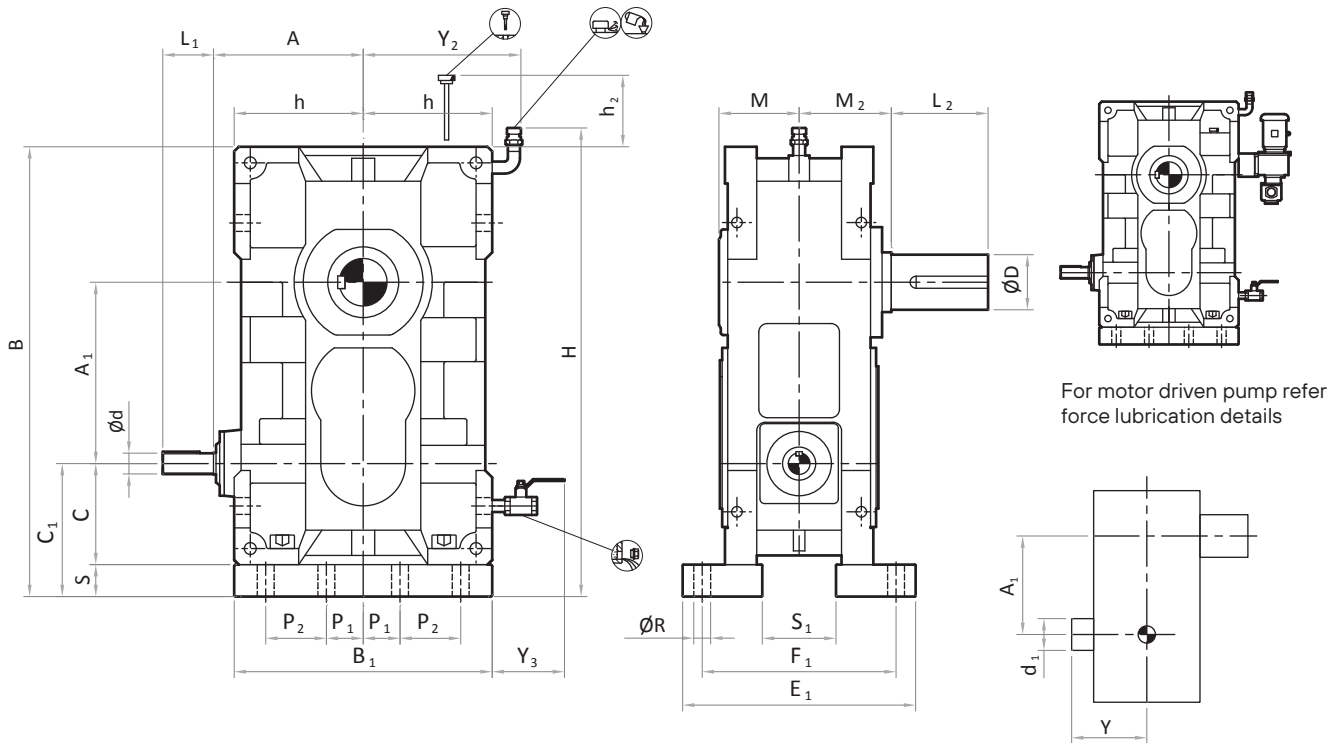

Size	Input Shaft				Mounting Dimensions	Output Shaft					Backstop			Weight (Kg) ¹⁾	Oil Quantity (Liters) ¹⁾
	i = 12.5 - 50		i = 56 - 71			D	L ₂	M ₂	M	A ₁	d ₁	Y			
	i = 16 - 63		i = 71 - 90												
	d	L ₁	d	L ₁		A									
720	55	120	45	110	350	140	250	240	230	453	210	350	980	60	
721	55	120	45	110	350	160	300	240	230	502	210	350	1125	65	
722	70	150	55	120	425	170	300	270	260	556	245	395	1640	103	
723	70	150	55	120	425	180	340	270	260	617	245	395	1845	105	
724	80	160	60	130	490	200	340	335	310	647	290	470	2575	188	
725	80	160	60	130	490	210	350	335	310	712	290	470	2895	191	

Size	Foundation																
	A ₁	B	B ₁	C	C ₁ ^{-0.5}	E ₁	F ₁	h ^{-0.5}	H ¹⁾	h ₂ ¹⁾	P ₁	P ₂	R	S	S ₁	Y ₂ ¹⁾	Y ₃ ¹⁾
720	453	1095	640	257	307	540	470	320	1230	600	120	140	27	50	210	410	230
721	502	1194	640	257	307	540	470	320	1330	600	120	140	27	50	210	410	230
722	556	1320	760	304	364	650	560	380	1450	700	140	180	33	60	245	470	230
723	617	1441	760	304	364	650	560	380	1580	700	140	180	33	60	245	470	230
724	647	1525	880	353	418	760	660	440	1650	700	170	200	39	70	300	530	230
725	712	1655	880	353	418	760	660	440	1780	700	170	200	39	70	300	530	230

1) Approximate values

Compact Bevel Helical gear units

6.5 Type C3 – Gear unit shaft arrangement views

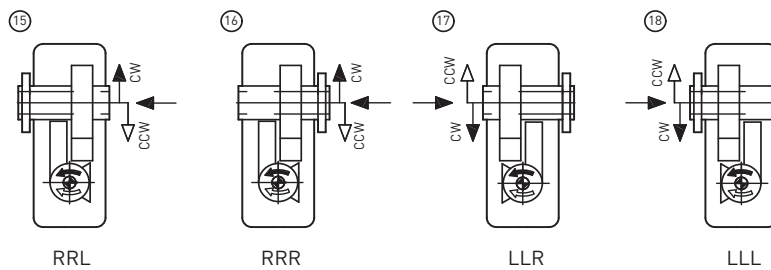
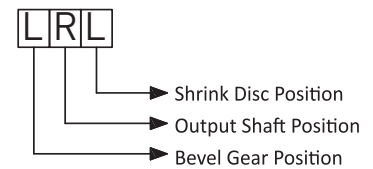
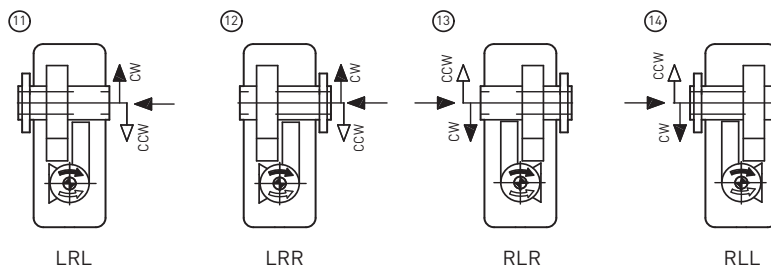
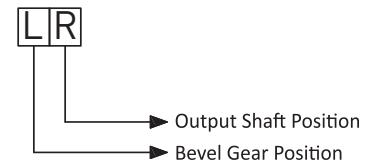
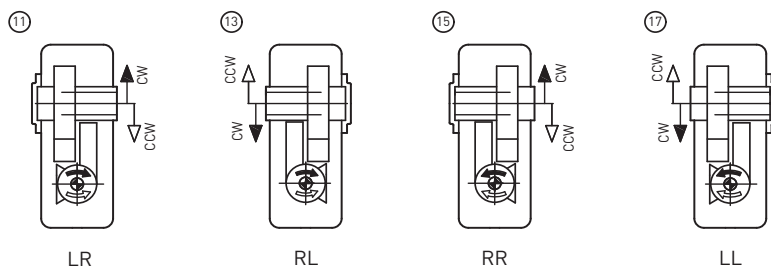
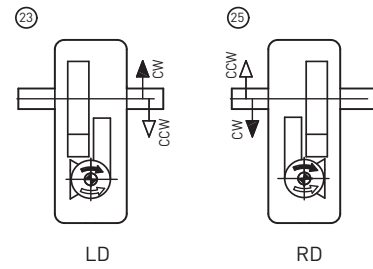
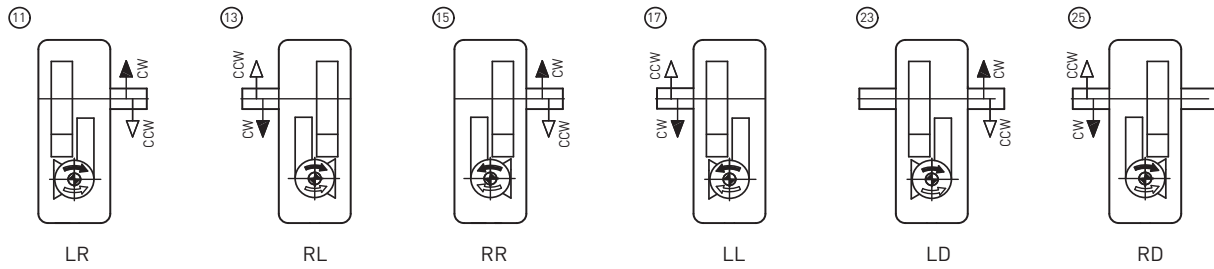

Intermediate Extension

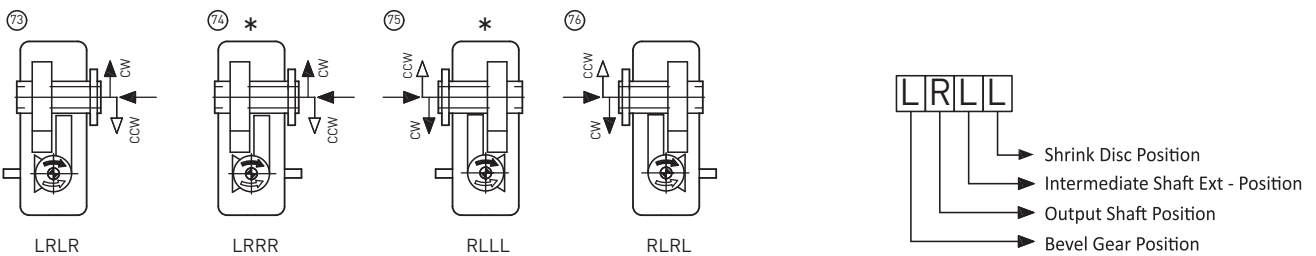
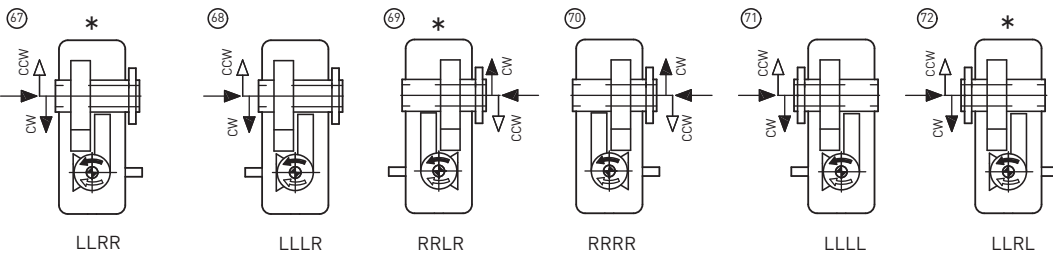
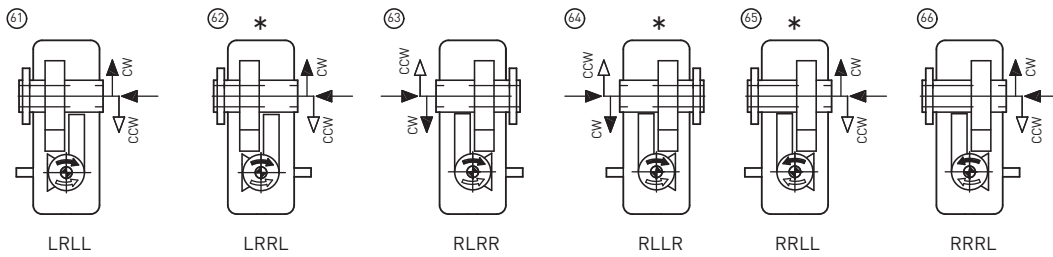
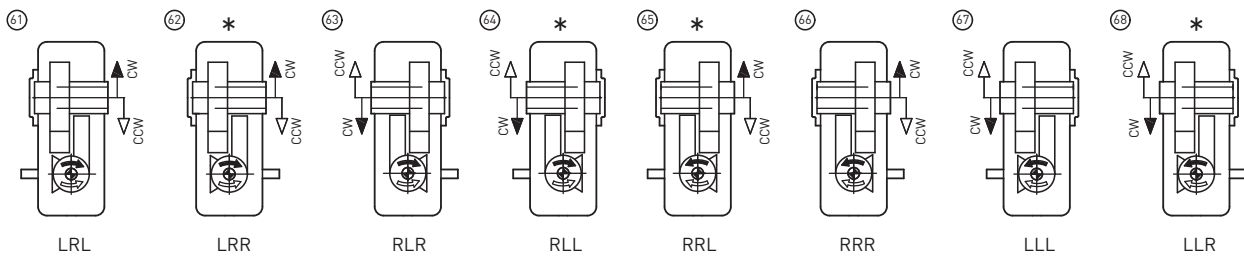
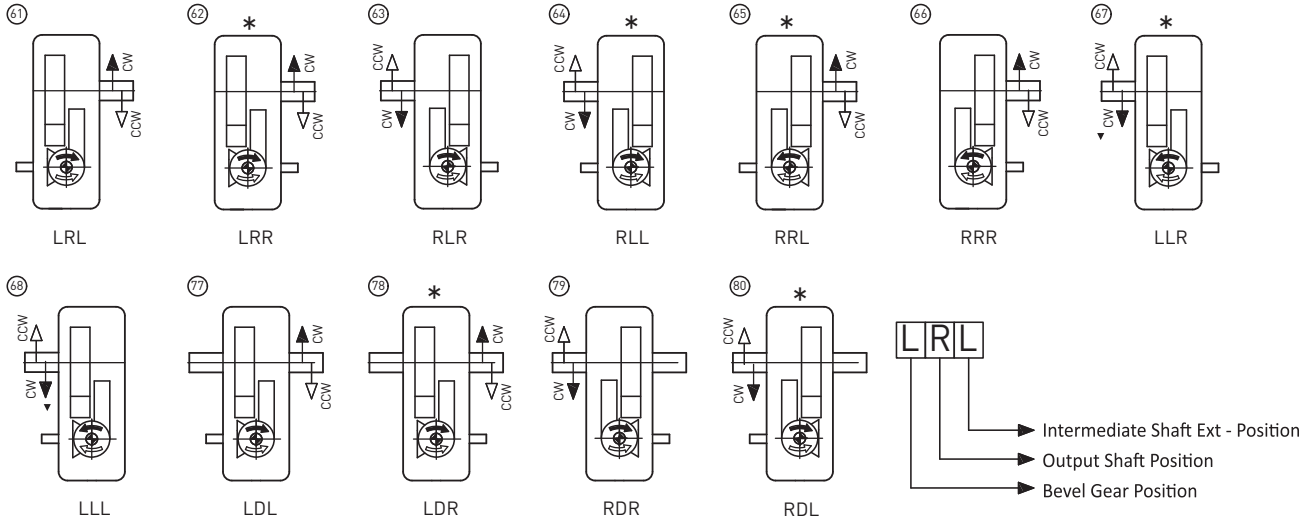

Holdback



Holdback

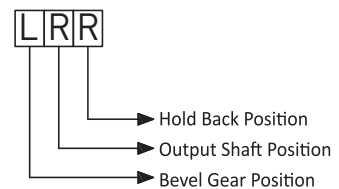
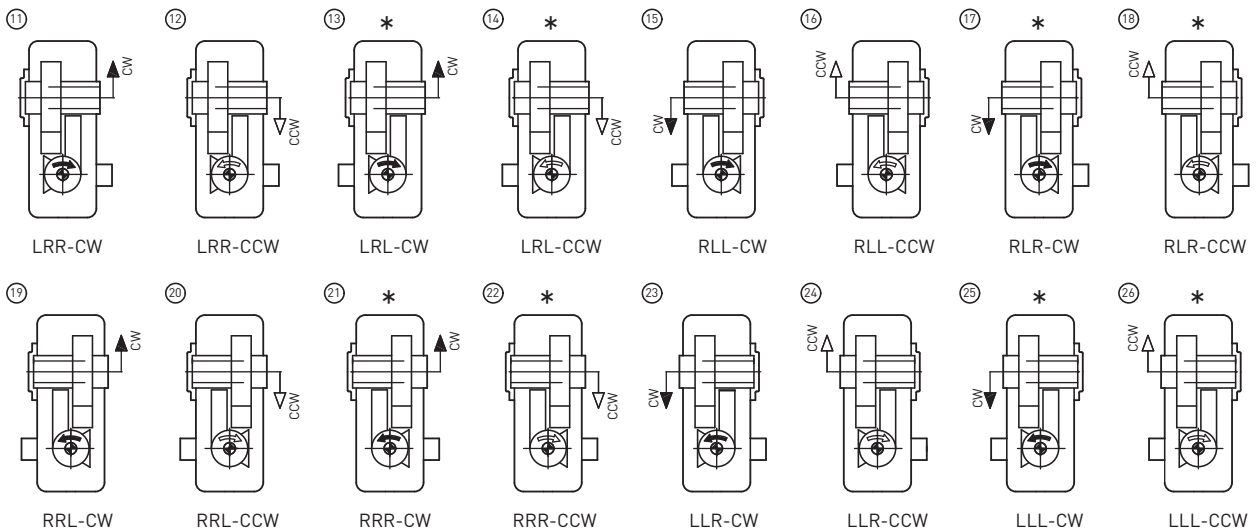
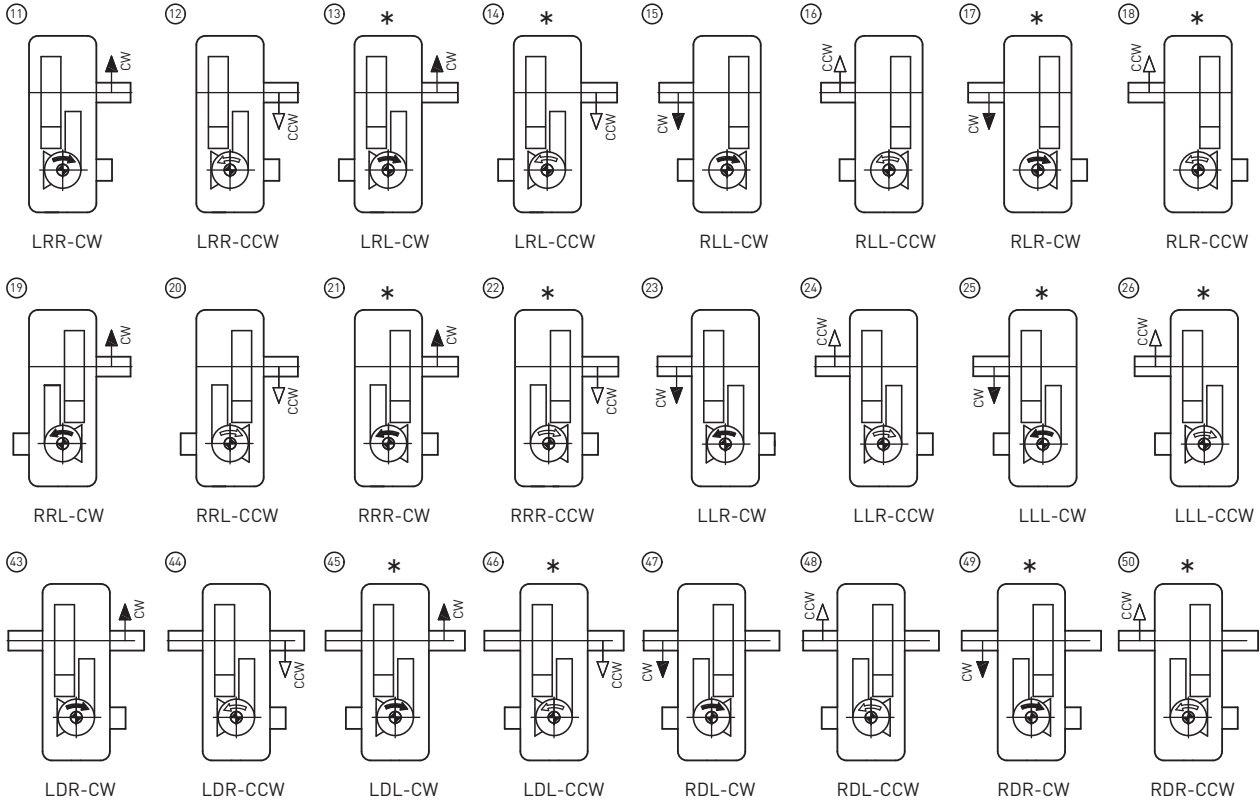

Intermediate Extension & Holdback

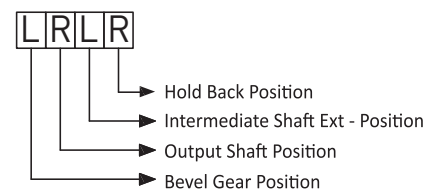
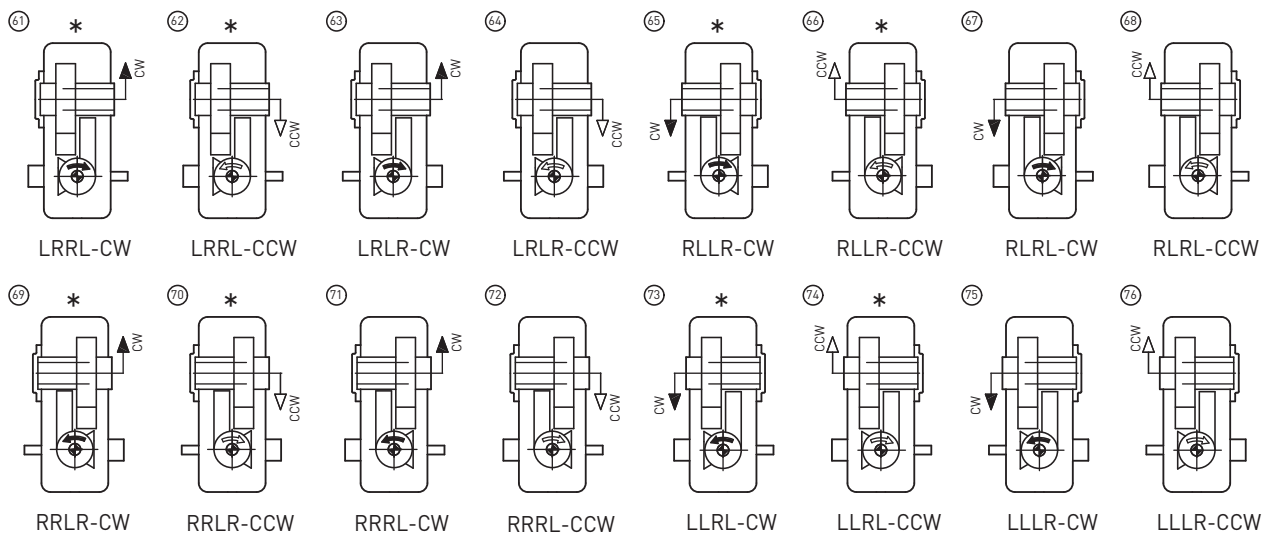
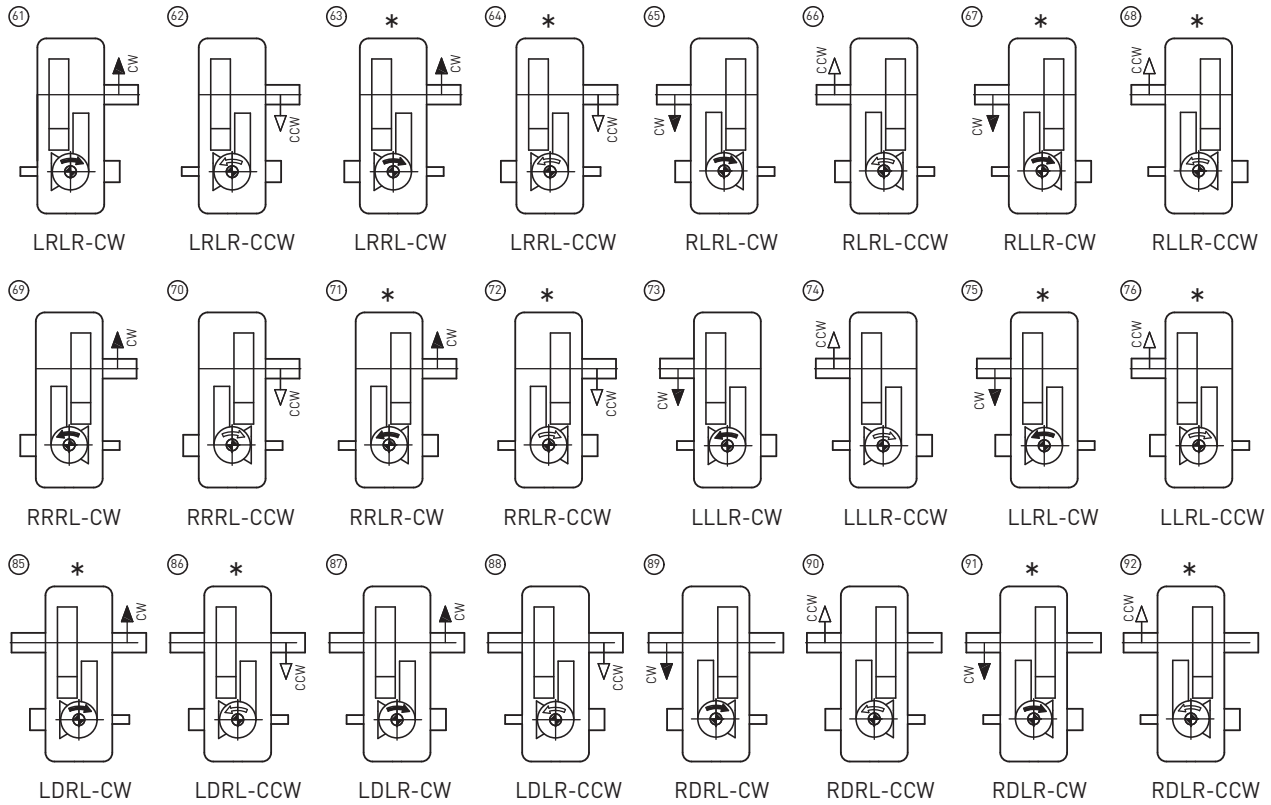

Intermediate Extension & Holdback

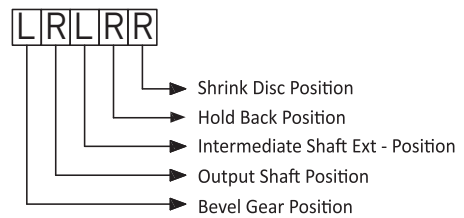
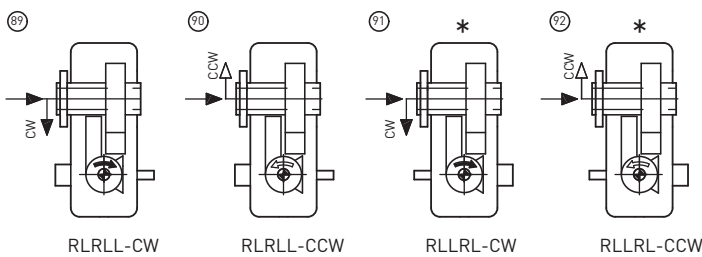
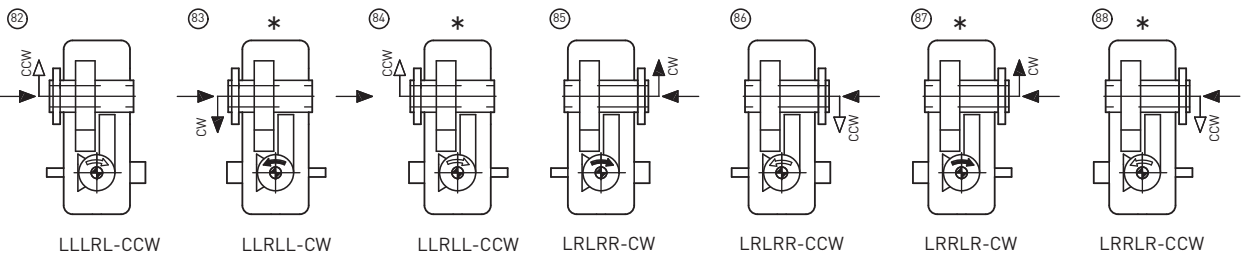
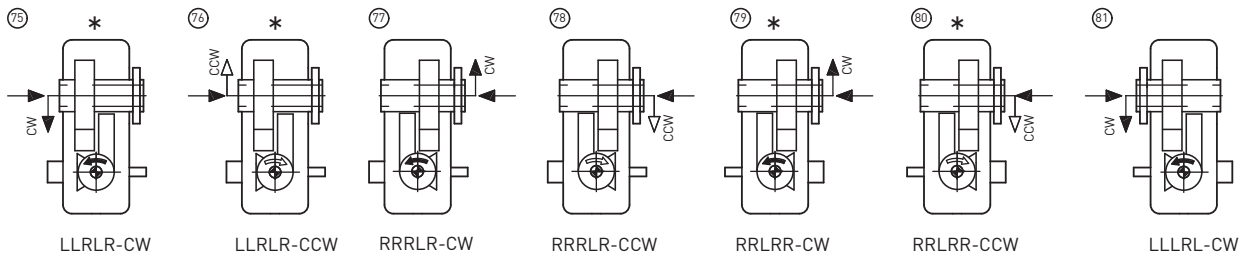
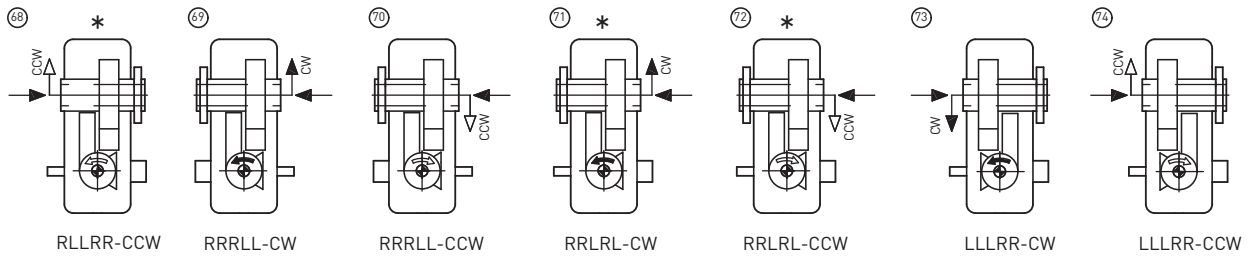
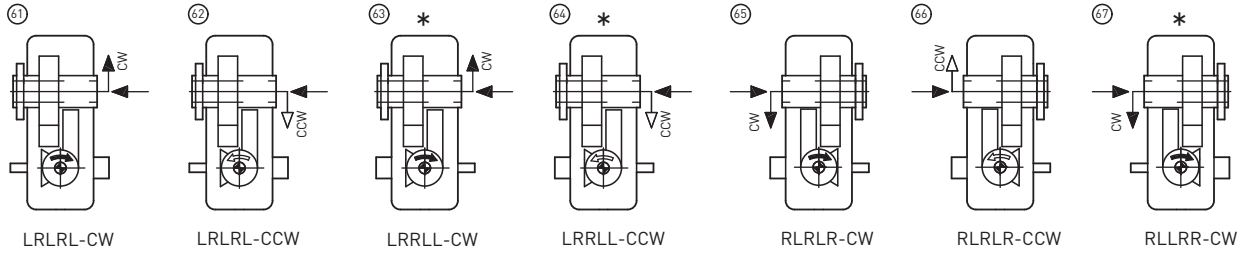

Compact Bevel Helical gear units horizontal mounting position

6.6 Type C4H - Gear unit dimensions, Four stage, Size 716 to 719

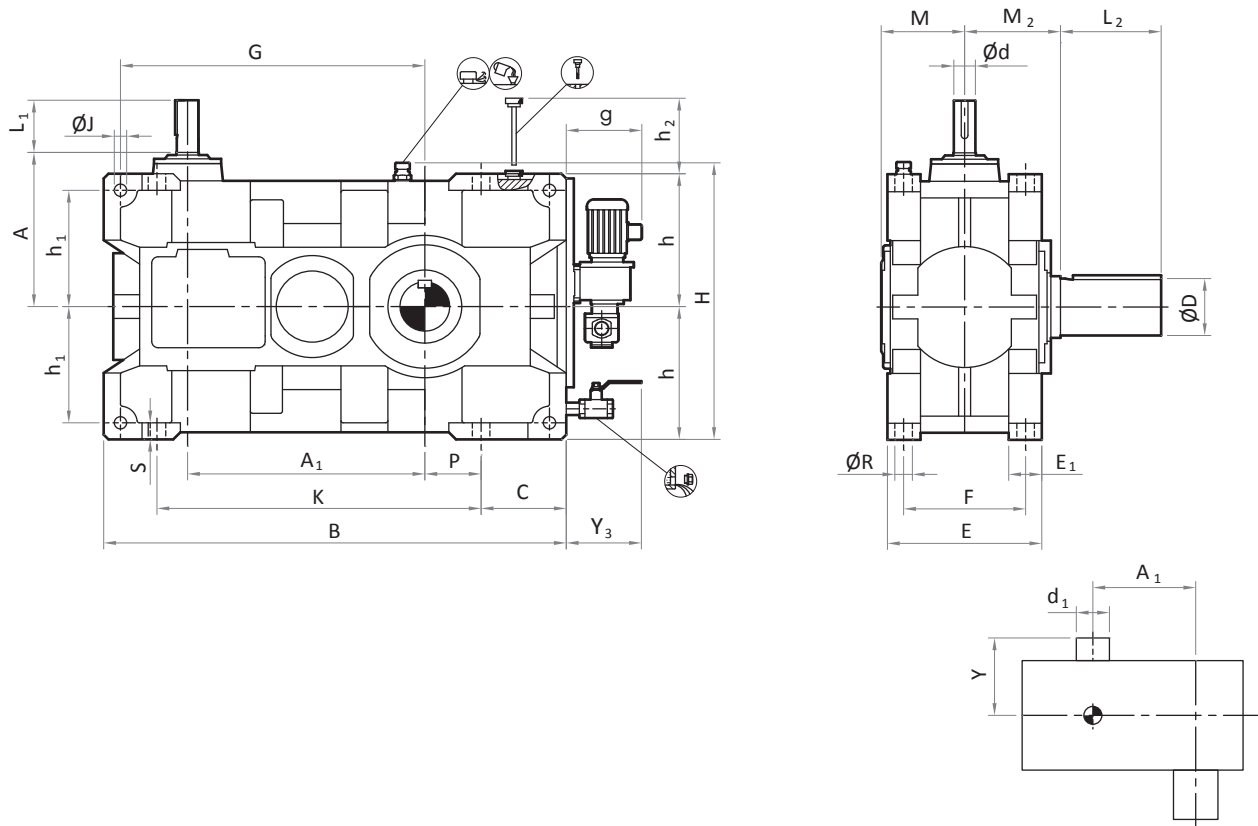

Size	Input Shaft						Mounting Dimensions	Output Shaft					Backstop		Weight (Kg) ¹⁾	Oil Quantity (Liters) ¹⁾
	i = 80 - 200		i = 224 - 315		i = 355			A	D	L ₂	M ₂	M	d ₁	Y		
	d	L ₁	d	L ₁	d	L ₁										
716	28	85	20	80	20	80	280.2	100	210	170	160	95	220	335	16	
717	28	85	20	80	20	80	280.2	110	210	170	160	95	220	380	17	
718	30	85	30	85	22	80	305.3	120	210	200	185	132	255	570	30	
719	30	85	30	85	22	80	305.3	130	240	200	185	132	255	650	32	

Size	Foundation																	
	A ₁	B	C	E	E ₁	F	G	h ^{-0.5}	h ₁	H ¹⁾	h ₂ ¹⁾	J	K	P	R	S	Y ₃ ¹⁾	g ¹⁾
716	377	805	145	270	55	224	530	230	200	510	405	23	560	100	18	28	180	350
717	414	882	145	270	55	224	567	230	200	510	405	23	640	140	18	28	180	350
718	466.1	965	165	322	69	270	635	280	245	610	415	27	695	130	23	35	180	350
719	515.1	1064	165	322	69	270	684	280	245	610	415	27	795	180	23	35	180	350

1) Approximate values

Compact Bevel Helical gear units horizontal mounting position

6.6 Type C4H - Gear unit dimensions, Four stage, Size 720 to 725

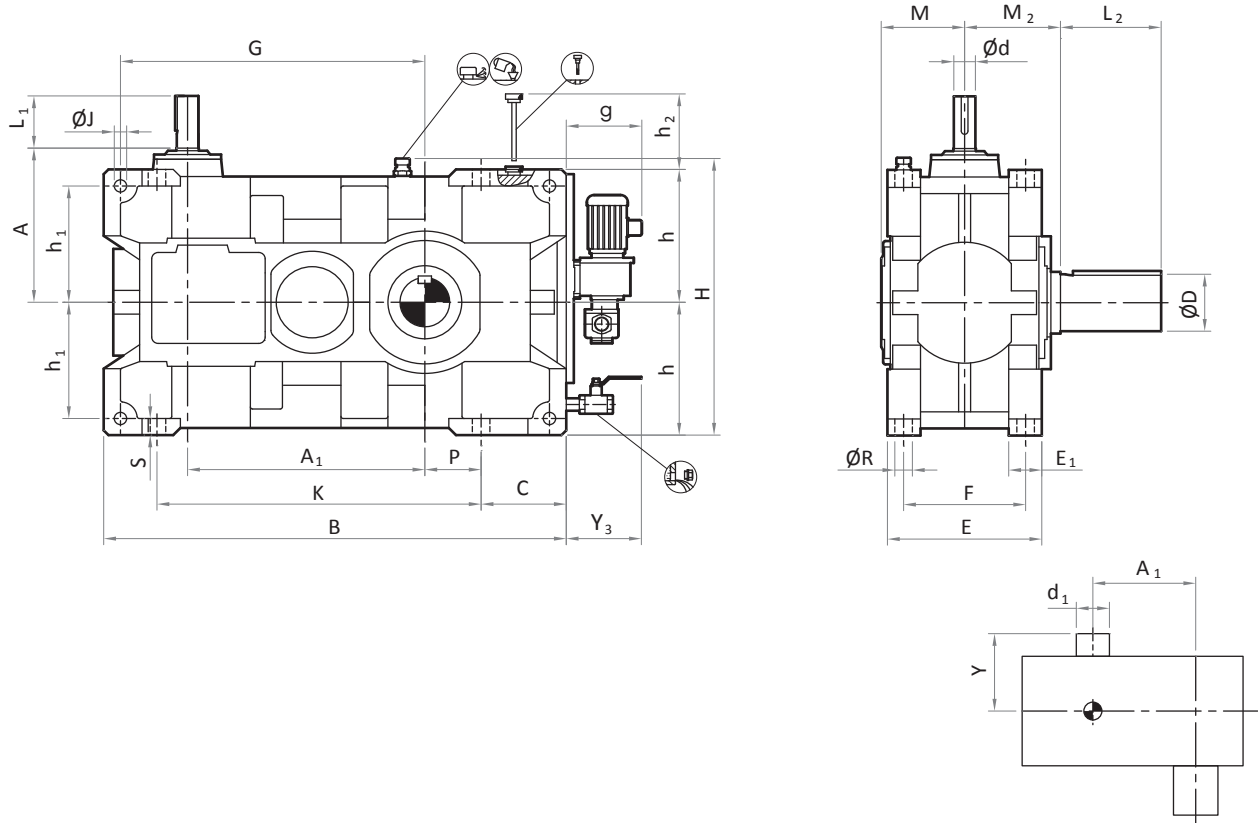

Size	Input Shaft						Mounting Dimensions	Output Shaft					Backstop		Weight (Kg) ¹⁾	Oil Quantity (Liters) ¹⁾
	i = 80 - 200		i = 224 - 315		i = 355			A	D	L ₂	M ₂	M	d ₁	Y		
	d	L ₁	d	L ₁	d	L ₁										
720	35	90	32	90	32	90	354.4	140	250	240	230	140	315	930	49	
721	35	90	32	90	32	90	354.4	160	300	240	230	140	315	1070	51	
722	45	110	35	90	35	90	420	170	300	270	260	175	365	1500	79	
723	45	110	35	90	35	90	420	180	340	270	260	175	365	1700	85	
724	55	120	45	110	35	90	471.8	200	340	335	310	190	420	2400	142	
725	55	120	45	110	35	90	471.8	210	350	335	310	190	420	2710	146	

Size	Foundation																	
	A ₁	B	C	E	E ₁	F	G	h ^{-0.5}	h ₁	H ¹⁾	h ₂ ¹⁾	J	K	P	R	S	Y ₃ ¹⁾	g ¹⁾
720	551.8	1125	175	400	80	340	750	320	280	690	500	33	830	160	27	40	250	350
721	601	1224	175	400	80	340	799	320	280	690	500	33	930	210	27	40	250	350
722	684.8	1355	210	474	100	400	915	380	330	810	650	39	1000	190	33	50	225	350
723	745.8	1476	210	474	100	400	976	380	330	810	650	39	1120	250	33	50	225	350
724	787.6	1540	220	560	110	475	1035	440	380	930	700	45	1165	235	39	60	225	350
725	852.6	1670	220	560	110	475	1100	440	380	930	700	45	1290	300	39	60	225	350

1) Approximate values

Compact Bevel Helical gear units vertical mounting position

6.7 Type C4V - Gear unit dimensions, Four stage, Size 716 to 719

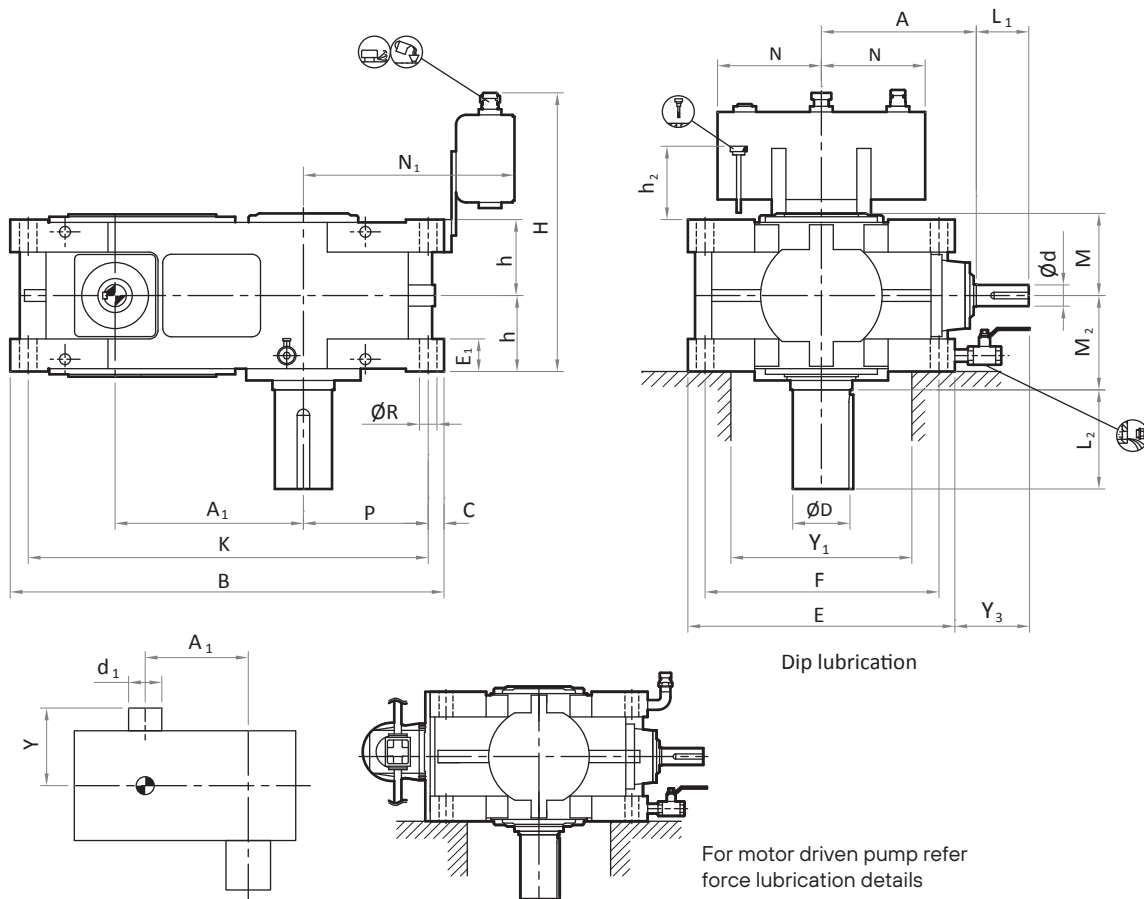

Size	Input Shaft						Mounting Dimensions	Output Shaft					Backstop		Weight (Kg) ¹⁾	Oil Quantity (Liters) ¹⁾
	i = 80 - 200		i = 224 - 315		i = 355			D	L ₂	M ₂	M	d ₁	Y			
	d	L ₁	d	L ₁	d	L ₁										
716	28	85	20	80	20	80	280.2	100	210	170	160	95	220	335	32	
717	28	85	20	80	20	80	280.2	110	210	170	160	95	220	380	36	
718	30	85	30	85	22	80	305.3	120	210	200	185	132	255	570	62	
719	30	85	30	85	22	80	305.3	130	240	200	185	132	255	650	66	

Size	Foundation															
	A ₁	B	C	E	E ₁	F	h ^{-0.5}	H ¹⁾	h ₂ ¹⁾	K	N	P	R	Y ₁ ¹⁾	Y ₃ ¹⁾	N ₁
716	377	805	30	460	55	400	135	500	200	745	190	215	23	280	180	395
717	414	882	30	460	55	400	135	500	200	822	190	255	23	280	180	435
718	466.1	965	35	560	69	490	161	550	240	895	190	260	27	350	180	445
719	515.1	1064	35	560	69	490	161	550	240	994	190	310	27	350	180	495

1) Approximate values

Compact Bevel Helical gear units vertical mounting position

6.7 Type C4V - Gear unit dimensions, Four stage, Size 720 to 725

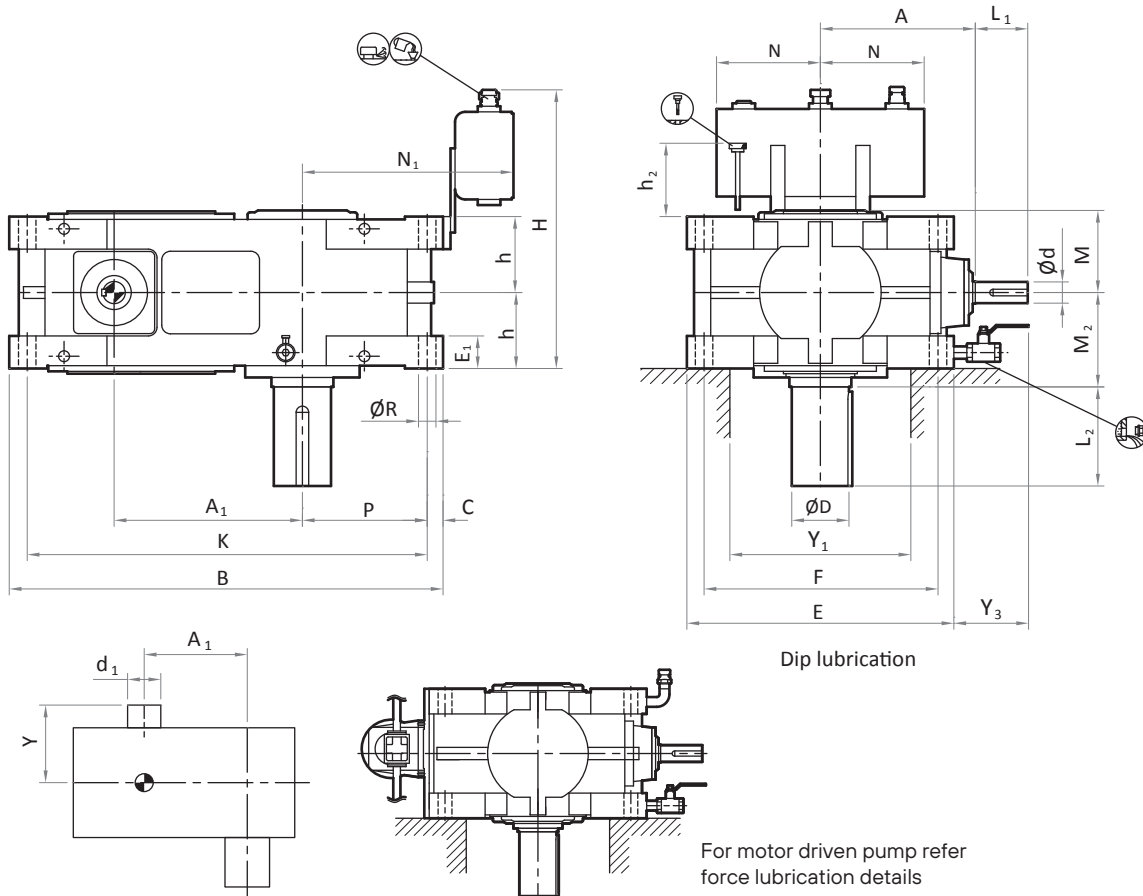

Size	Input Shaft						Mounting Dimensions	Output Shaft					Backstop		Weight (Kg) ¹⁾	Oil Quantity (Liters) ¹⁾
	i = 80 - 200		i = 224 - 315		i = 355			D	L ₂	M ₂	M	d ₁	Y			
	i = 100 - 250		i = 280 - 400		i = 450											
	d	L ₁	d	L ₁	d	L ₁		A	D	L ₂	M ₂	M	d ₁	Y		
720	35	90	32	90	32	90	354.4	140	250	240	230	140	315	930	101	
721	35	90	32	90	32	90	354.4	160	300	240	230	140	315	1070	106	
722	45	110	35	90	35	90	420	170	300	270	260	175	365	1500	163	
723	45	110	35	90	35	90	420	180	340	270	260	175	365	1700	176	
724	55	120	45	110	35	90	471.8	200	340	335	310	190	420	2400	293	
725	55	120	45	110	35	90	471.8	210	350	335	310	190	420	2710	300	

Size	Foundation															
	A ₁	B	C	E	E ₁	F	h ^{-0.5}	H ¹⁾	h ₂ ¹⁾	K	N	P	R	Y ₁ ¹⁾	Y ₃ ¹⁾	N ₁
720	551.8	1125	40	640	80	560	200	750	300	1045	300	295	33	420	230	550
721	601	1224	40	640	80	560	200	750	300	1144	300	345	33	420	230	600
722	684.8	1355	40	760	100	660	237	820	350	1275	300	360	39	530	230	615
723	745.8	1476	40	760	100	660	237	820	350	1396	300	420	39	530	230	675
724	787.6	1540	50	880	110	760	280	900	420	1440	300	405	45	610	230	675
725	852.6	1670	50	880	110	760	280	900	420	1570	300	470	45	610	230	735

1) Approximate values

Compact Bevel Helical gear units over driven mounting position

6.8 Type C40 - Gear unit dimensions, Four stage, Size 716 to 719

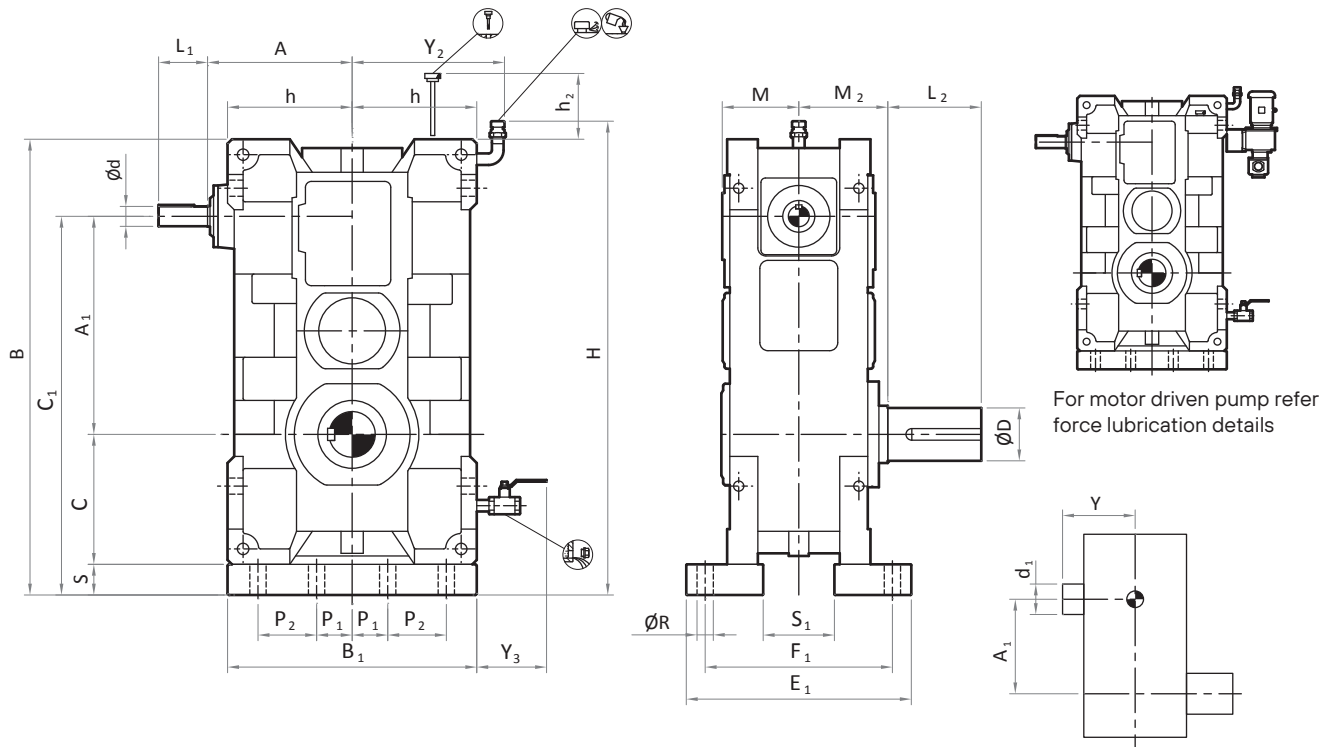

Size	Input Shaft						Mounting Dimensions	Output Shaft					Backstop		Weight (Kg) ¹⁾	Oil Quantity (Liters) ¹⁾
	i = 80 - 200		i = 224 - 315		i = 355			D	L ₂	M ₂	M	d ₁	Y			
	d	L ₁	d	L ₁	d	L ₁										
716	28	85	20	80	20	80	280.2	100	210	170	160	95	220	360	22	
717	28	85	20	80	20	80	280.2	110	210	170	160	95	220	405	25	
718	30	85	30	85	22	80	305.3	120	210	200	185	132	255	620	43	
719	30	85	30	85	22	80	305.3	130	240	200	185	132	255	700	46	

Size	Foundation																
	A ₁	B	B ₁	C	C ₁ ^{-0.5}	E ₁	F ₁	h ^{-0.5}	H ¹⁾	h ₂ ¹⁾	P ₁	P ₂	R	S	S ₁	Y ₂ ¹⁾	Y ₃ ¹⁾
716	377	835	460	245	652	390	335	230	950	400	90	90	18	30	150	315	180
717	414	912	460	285	729	390	335	230	1025	400	90	90	18	30	150	315	180
718	466.1	1005	560	295	801.1	470	410	280	1125	450	100	120	23	40	175	370	180
719	515.1	1104	560	345	900.1	470	410	280	1220	450	100	120	23	40	175	370	180

1) Approximate values

Compact Bevel Helical gear units over driven mounting position

6.8 Type C40 - Gear unit dimensions, Four stage, Size 720 to 725

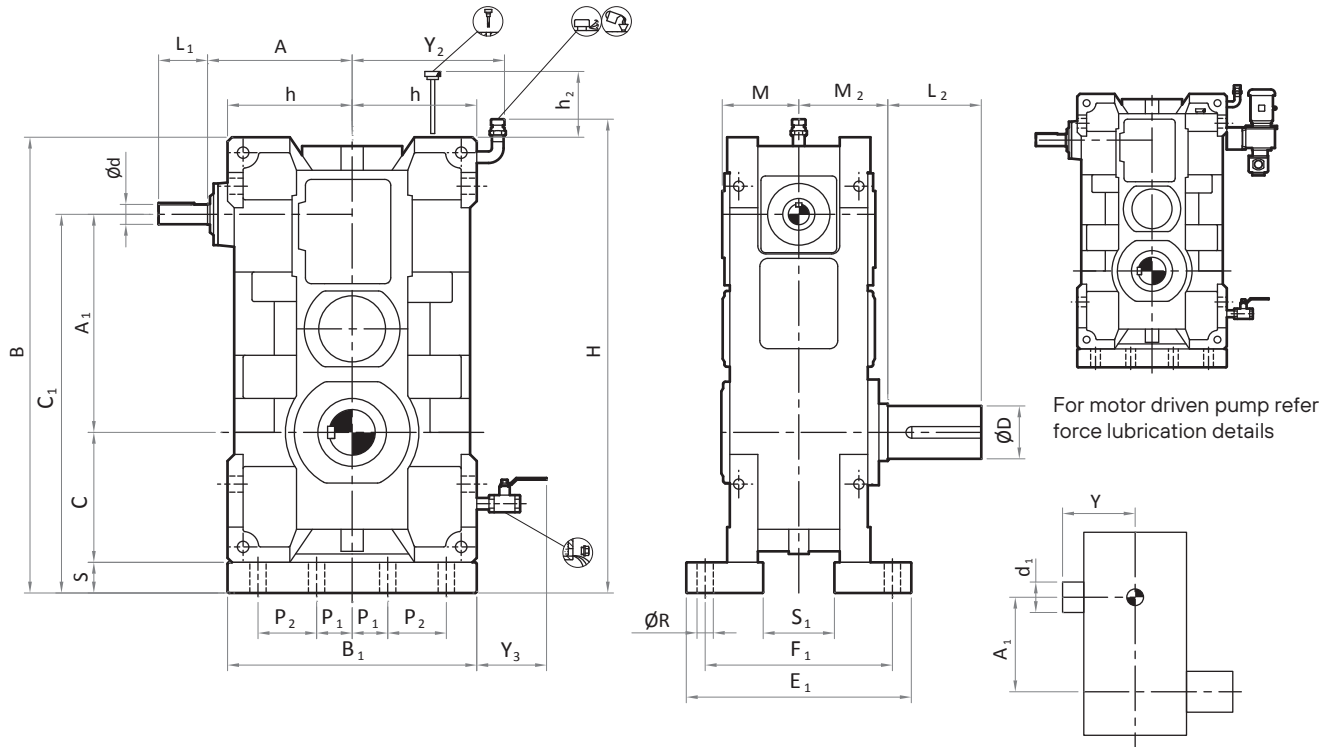

Size	Input Shaft						Mounting Dimensions	Output Shaft					Backstop		Weight (Kg) ¹⁾	Oil Quantity (Liters) ¹⁾
	i = 80 - 200		i = 224 - 315		i = 355			A	D	L ₂	M ₂	M	d ₁	Y		
	d	L ₁	d	L ₁	d	L ₁										
720	35	90	32	90	32	90	354.4	140	250	240	230	140	315	1010	70	
721	35	90	32	90	32	90	354.4	160	300	240	230	140	315	1150	73	
722	45	110	35	90	35	90	420	170	300	270	260	175	365	1640	114	
723	45	110	35	90	35	90	420	180	340	270	260	175	365	1840	122	
724	55	120	45	110	35	90	471.8	200	340	335	310	190	420	2615	204	
725	55	120	45	110	35	90	471.8	210	350	335	310	190	420	2925	209	

Size	Foundation																
	A ₁	B	B ₁	C	C ₁ ^{-0.5}	E ₁	F ₁	h ^{-0.5}	H ¹⁾	h ₂ ¹⁾	P ₁	P ₂	R	S	S ₁	Y ₂ ¹⁾	Y ₃ ¹⁾
720	551.8	1175	640	335	936.8	540	470	320	1340	600	120	140	27	50	210	410	230
721	601	1274	640	385	1036	540	470	320	1430	600	120	140	27	50	210	410	230
722	684.8	1415	760	400	1144.8	650	560	380	1580	700	140	180	33	60	245	470	230
723	745.8	1536	760	460	1265.8	650	560	380	1700	700	140	180	33	60	245	470	230
724	787.6	1610	880	455	1312.6	760	660	440	1770	700	170	200	39	70	300	530	230
725	852.6	1740	880	520	1442.6	760	660	440	1900	700	170	200	39	70	300	530	230

1) Approximate values

Compact Bevel Helical gear units under driven mounting position

6.9 Type C4U - Gear unit dimensions, Four stage, Size 716 to 719

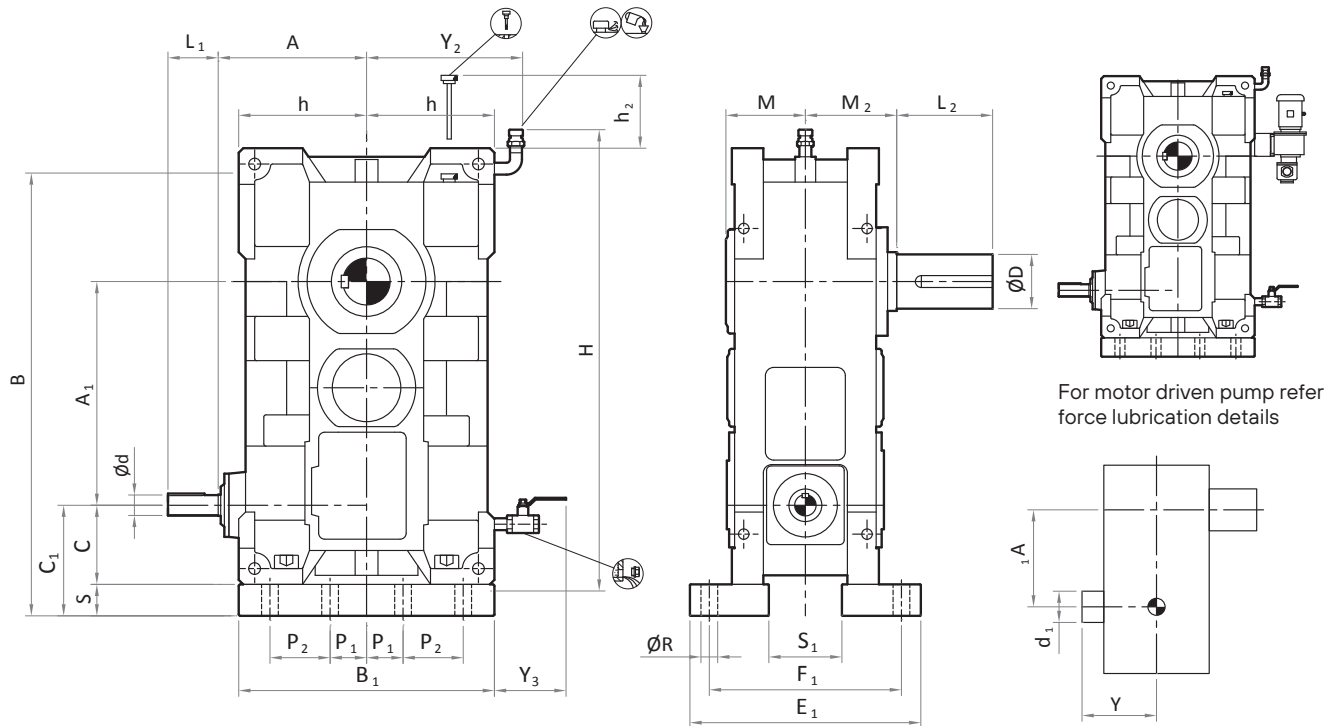

Size	Input Shaft						Mounting Dimensions	Output Shaft					Backstop		Weight (Kg) ¹⁾	Oil Quantity (Liters) ¹⁾
	i = 80 - 200		i = 224 - 315		i = 355			D	L ₂	M ₂	M	d ₁	Y			
	d	L ₁	d	L ₁	d	L ₁										
716	28	85	20	80	20	80	280.2	100	210	170	160	95	220	360	22	
717	28	85	20	80	20	80	280.2	110	210	170	160	95	220	405	25	
718	30	85	30	85	22	80	305.3	120	210	200	185	132	255	620	43	
719	30	85	30	85	22	80	305.3	130	240	200	185	132	255	700	46	

Size	Foundation																
	A ₁	B	B ₁	C	C ₁ ^{-0.5}	E ₁	F ₁	h ^{-0.5}	H ¹⁾	h ₂ ¹⁾	P ₁	P ₂	R	S	S ₁	Y ₂ ¹⁾	Y ₃ ¹⁾
716	377	835	460	183	213	390	335	230	950	400	90	90	18	30	150	315	180
717	414	912	460	183	213	390	335	230	1025	400	90	90	18	30	150	315	180
718	466.1	1005	560	203.9	243.9	470	410	280	1125	450	100	120	23	40	175	370	180
719	515.1	1104	560	203.9	243.9	470	410	280	1220	450	100	120	23	40	175	370	180

1) Approximate values

Compact Bevel Helical gear units under driven mounting position

6.9 Type C4U - Gear unit dimensions, Four stage, Size 720 to 725

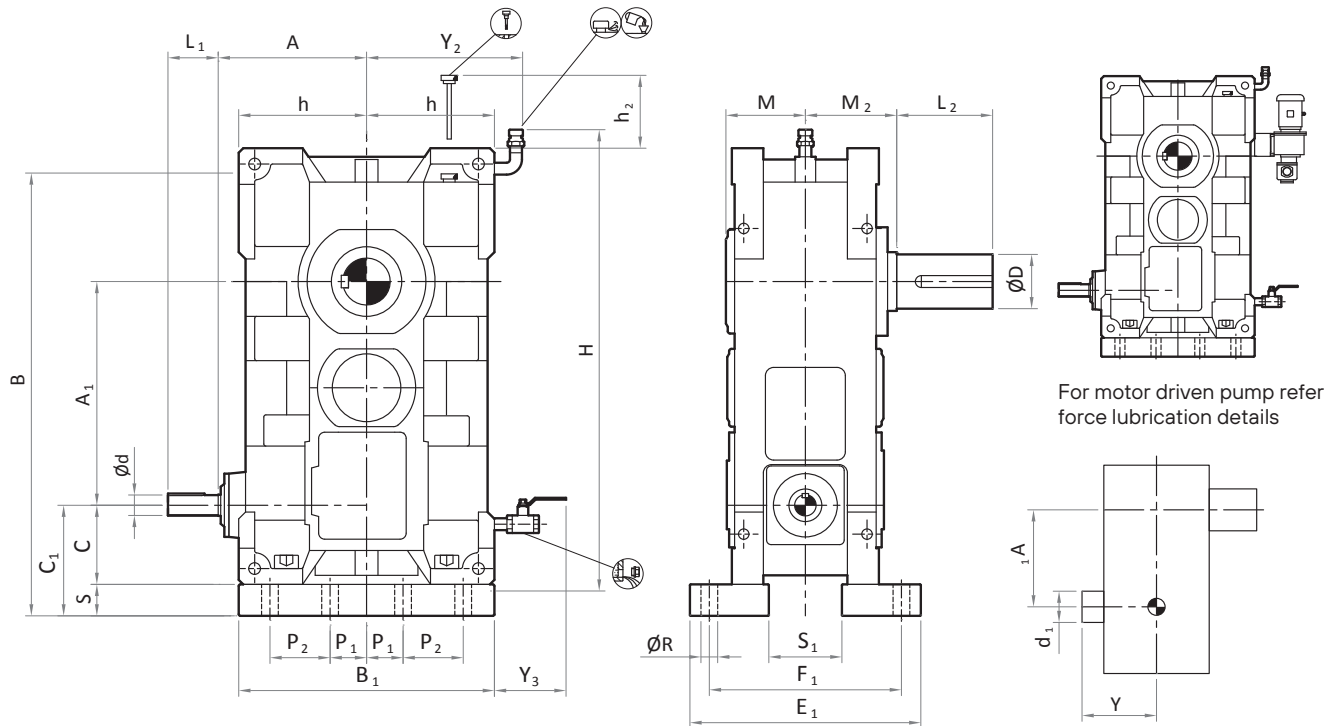

Size	Input Shaft						Mounting Dimensions	Output Shaft					Backstop		Weight (Kg) ¹⁾	Oil Quantity (Liters) ¹⁾
	i = 80 - 200		i = 224 - 315		i = 355			D	L ₂	M ₂	M	d ₁	Y			
	d	L ₁	d	L ₁	d	L ₁										
720	35	90	32	90	32	90	354.4	140	250	240	230	140	315	1010	70	
721	35	90	32	90	32	90	354.4	160	300	240	230	140	315	1150	73	
722	45	110	35	90	35	90	420	170	300	270	260	175	365	1640	114	
723	45	110	35	90	35	90	420	180	340	270	260	175	365	1840	122	
724	55	120	45	110	35	90	471.8	200	340	335	310	190	420	2615	204	
725	55	120	45	110	35	90	471.8	210	350	335	310	190	420	2925	209	

Size	Foundation																
	A ₁	B	B ₁	C	C ₁ ^{-0.5}	E ₁	F ₁	h ^{-0.5}	H ¹⁾	h ₂ ¹⁾	P ₁	P ₂	R	S	S ₁	Y ₂ ¹⁾	Y ₃ ¹⁾
720	551.8	1175	640	238.3	288.3	540	470	320	1340	600	120	140	27	50	210	410	230
721	601	1274	640	238.3	288.3	540	470	320	1430	600	120	140	27	50	210	410	230
722	684.8	1415	760	270.3	330.3	650	560	380	1580	700	140	180	33	60	245	470	230
723	745.8	1536	760	270.3	330.3	650	560	380	1700	700	140	180	33	60	245	470	230
724	787.6	1610	880	297.4	367.4	760	660	440	1770	700	170	200	39	70	300	530	230
725	852.6	1740	880	297.4	367.4	760	660	440	1900	700	170	200	39	70	300	530	230

1) Approximate values

Compact Bevel Helical gear units

6.10 Type C4 – Gear unit shaft arrangement views

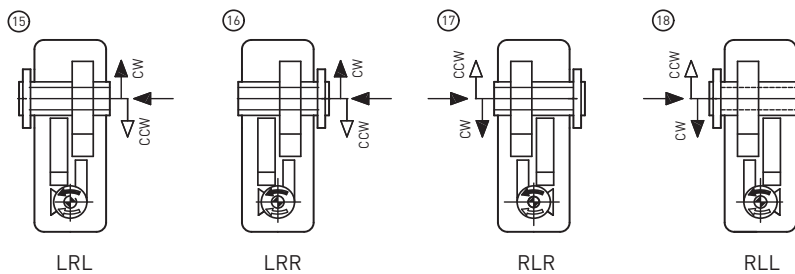
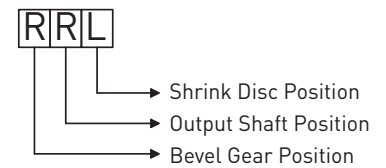
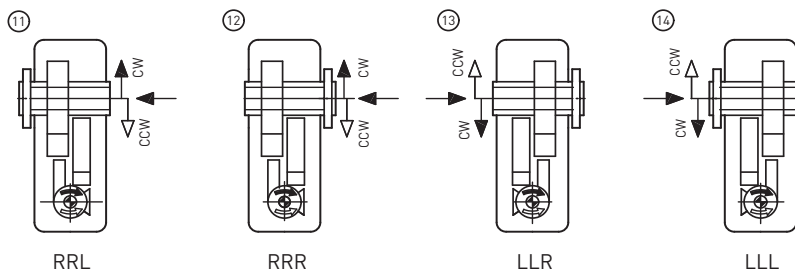
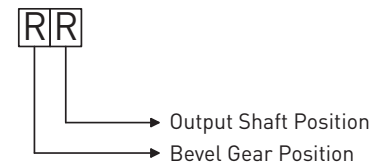
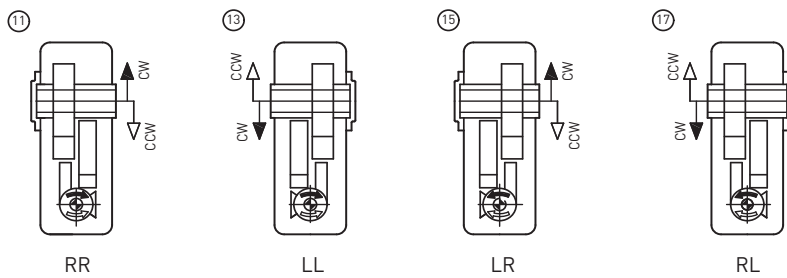
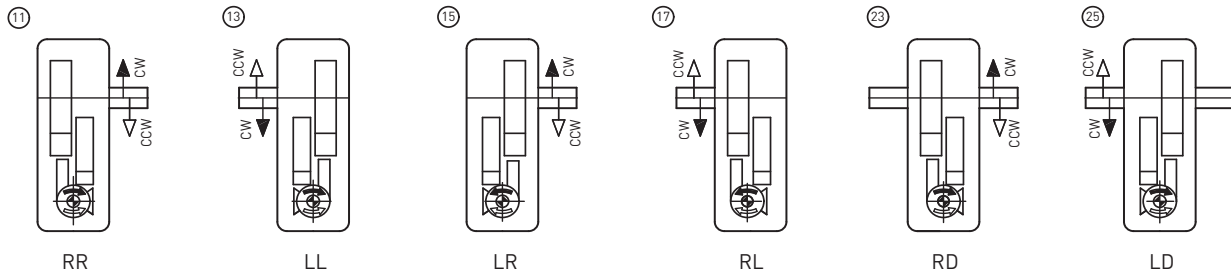

Holdback

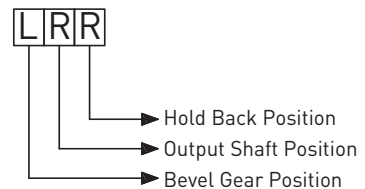
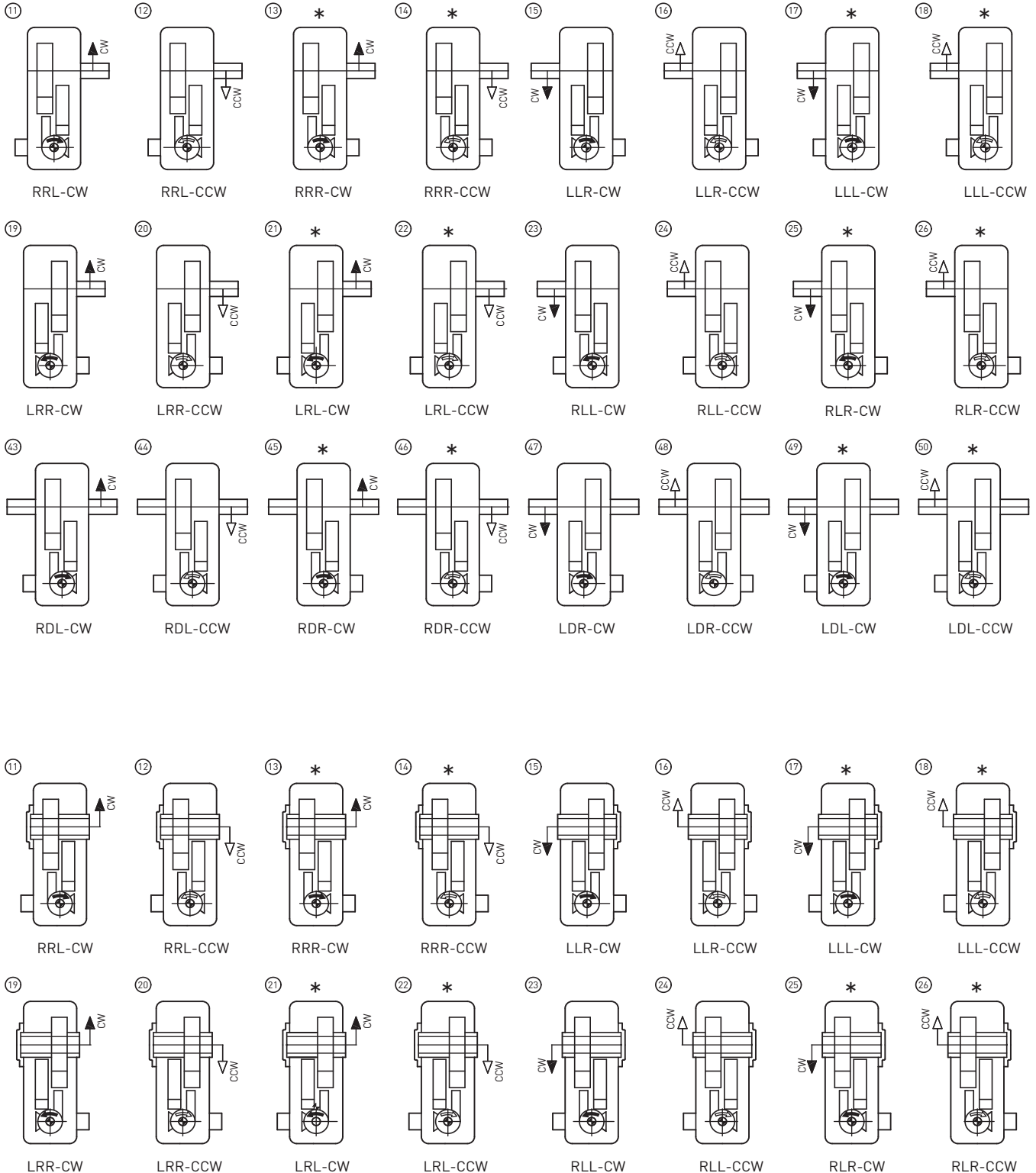

Holdback

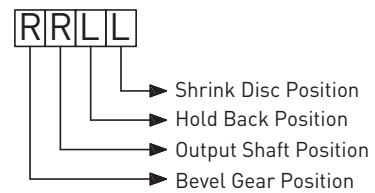
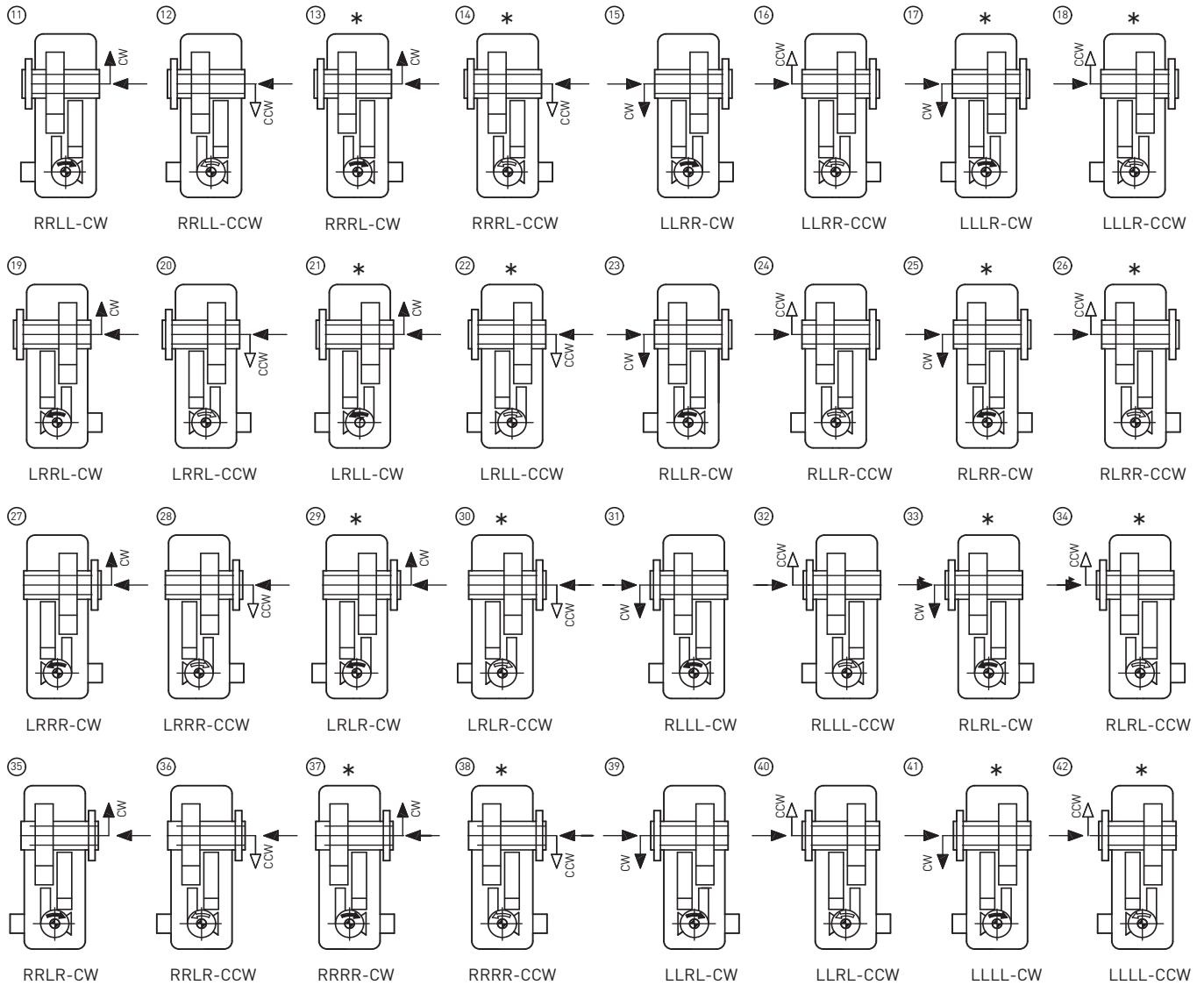

Intermediate Extension

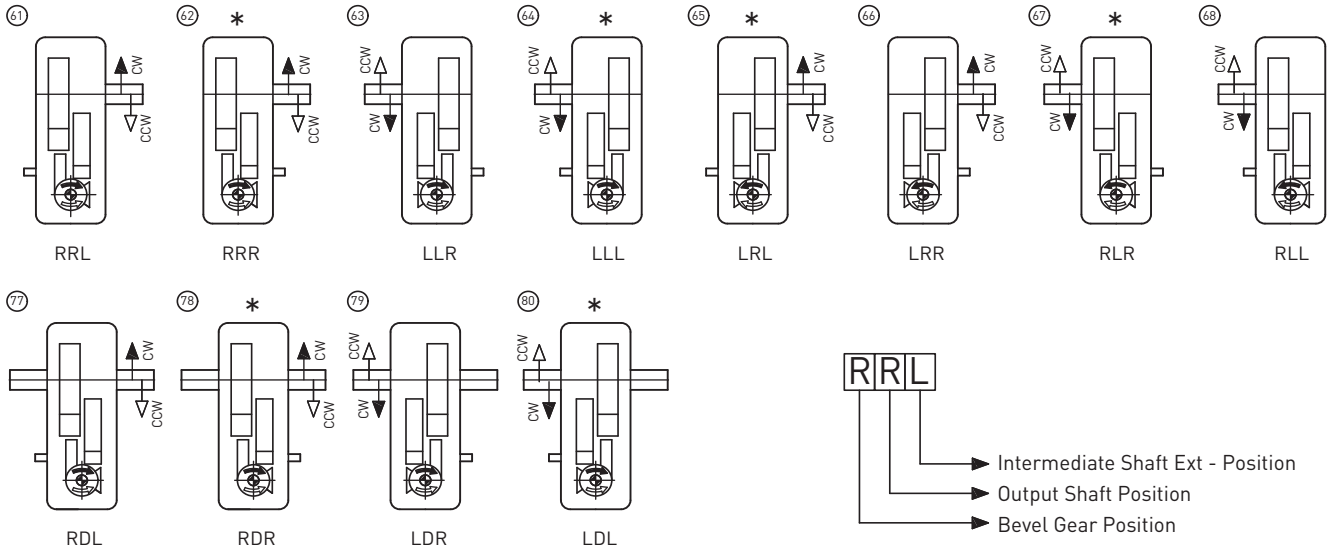

Intermediate Extension

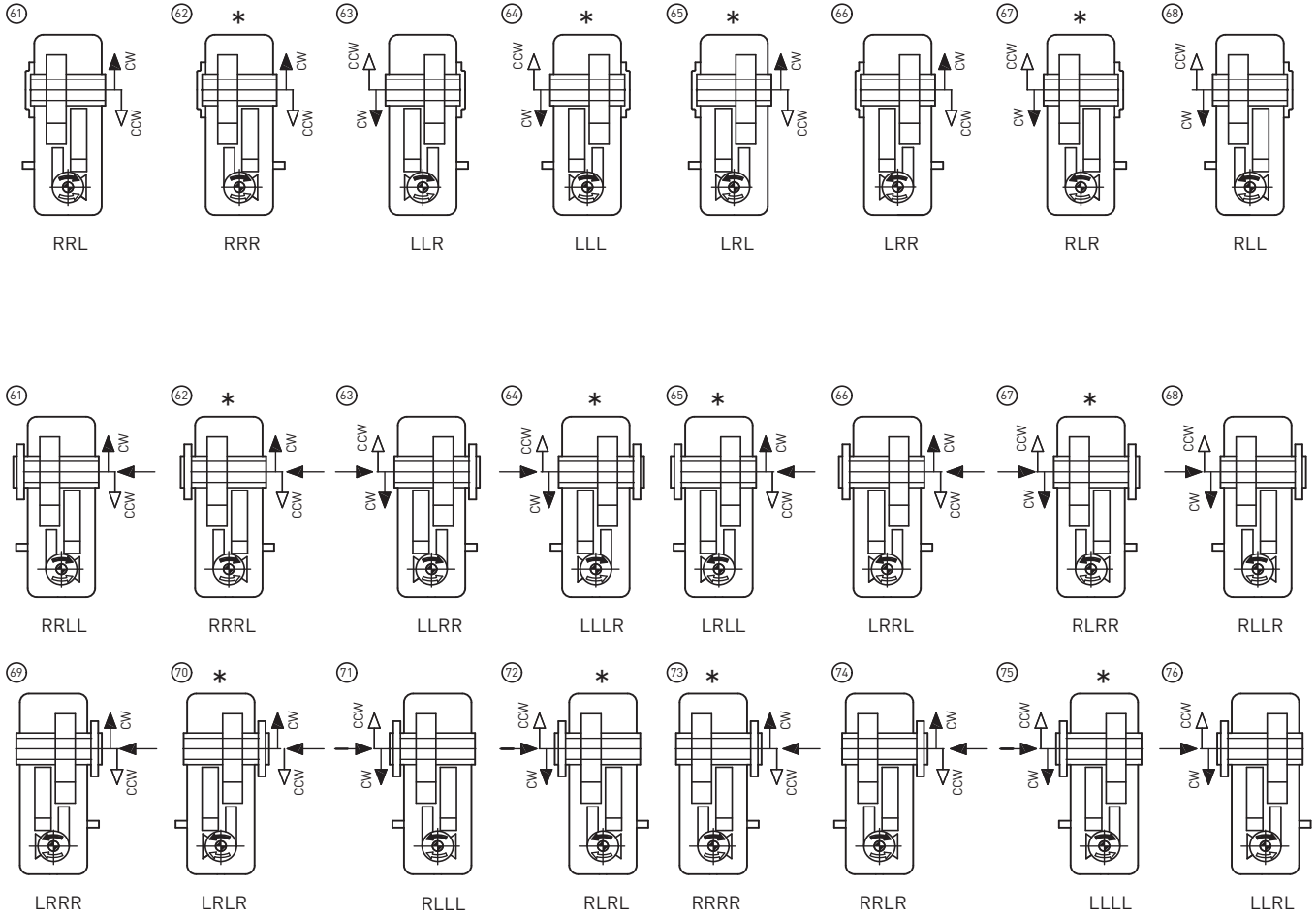

Intermediate Extension & Holdback

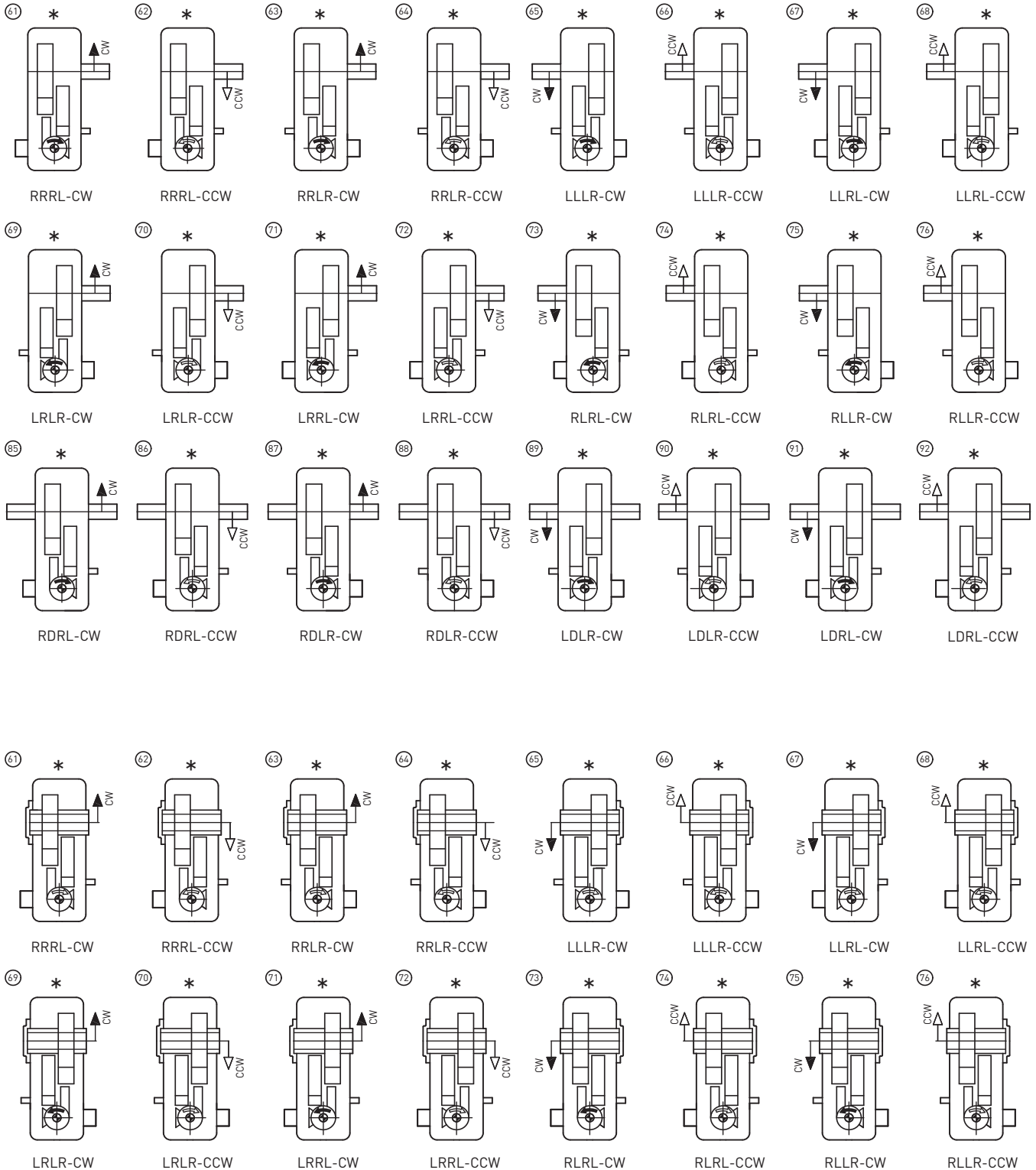

Intermediate Extension & Holdback

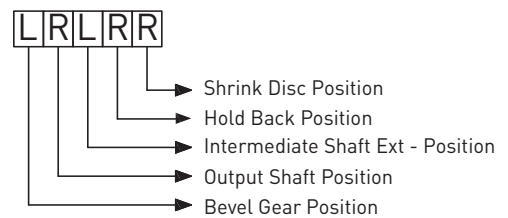
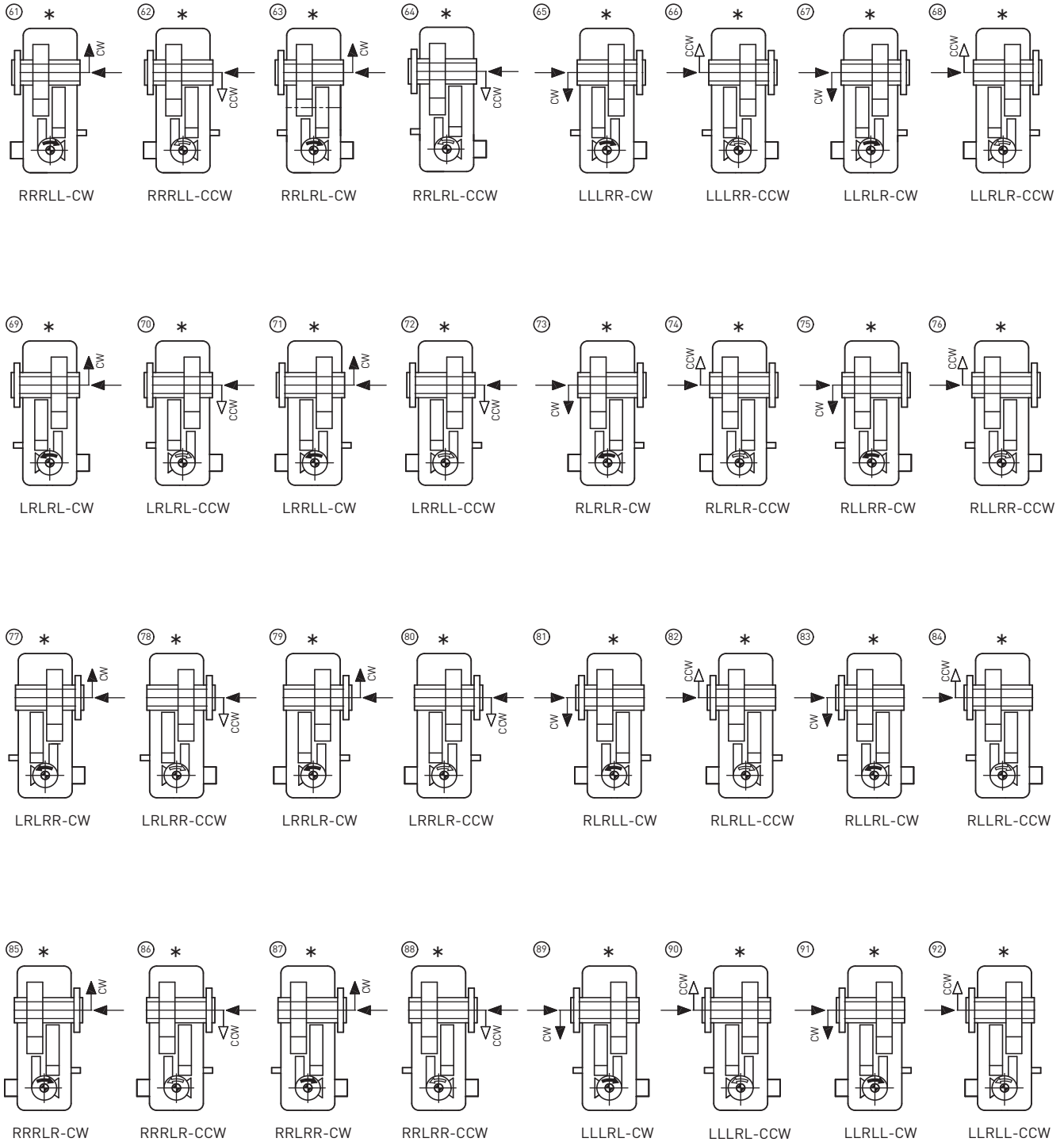



OUTPUT SHAFT DIMENSIONS

- 7.1 Output shaft types and dimensions
- 7.2 Hollow output shaft design with keyway
- 7.3 Standard hollow output shaft design with shrink disc
- 7.4 Alternate hollow output shaft design with shrink disc
- 7.5 Hollow output shaft with spline
- 7.6 Counter flange details for flange shaft
- 7.7 Permissible additional forces at output shaft

7.1 Output shaft types and dimensions

7.1.1. Solid output shaft double extended (N)

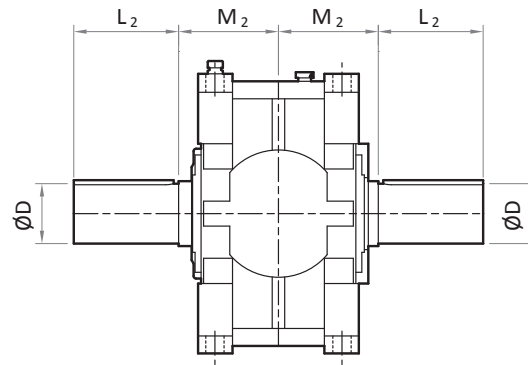

Size	Type : B2			Type : H2/H3/H4/B3/B4/C3/C4		
	D	L ₂	M ₂	D	L ₂	M ₂
712	45	90	155	-	-	-
713	45	90	155	-	-	-
714	60	120	195	60	120	150
715	80	160	210	80	160	150
716	90	160	220	100	210	170
717	110	210	220	110	210	170
718	120	210	255	120	210	200
719	130	240	255	130	240	200

Size	Type : B2			Type : H2/H3/H4/B3/B4/C3/C4		
	D	L ₂	M ₂	D	L ₂	M ₂
720	135	250	290	140	250	240
721	160	300	290	160	300	240
722	170	300	345	170	300	270
723	180	340	345	180	340	270
724	200	340	390	200	340	335
725	210	350	390	210	350	335

7.1.2. Solid output shaft without keyway (C)

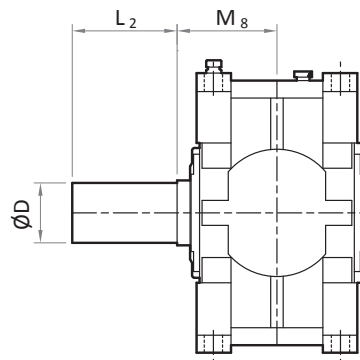

Size	Type : B2			Type : H2/H3/H4/B3/B4/C3/C4		
	D	L ₂	M ₈	D	L ₂	M ₈
712	45	80	155	-	-	-
713	45	80	155	-	-	-
714	60	90	195	60	90	150
715	80	125	210	80	125	150
716	90	125	220	115	125	170
717	115	125	220	115	125	170
718	120	155	255	120	155	200
719	130	155	255	130	155	200

Size	Type : B2			Type : H2/H3/H4/B3/B4/C3/C4		
	D	L ₂	M ₈	D	L ₂	M ₈
720	135	155	290	140	155	240
721	160	155	290	160	155	240
722	170	155	345	170	155	270
723	180	170	345	180	170	270
724	210	170	390	210	170	335
725	210	170	390	210	170	335

7.1 Output shaft types and dimensions

7.1.3. Solid shaft with spline, DIN-5480 - (V)

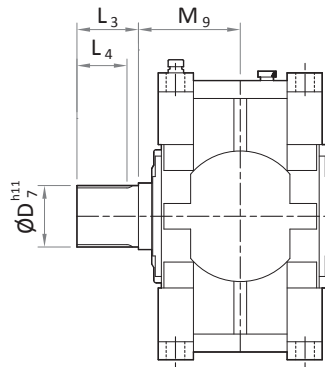

Size	Type : B2					Type : H2/H3/H4/B3/B4/C3/C4				
	Matching Internal spline	D ₇	L ₃	L ₄	M ₉	Matching Internal spline	D ₇	L ₃	L ₄	M ₉
712	N 45 × 2 × 21 × 9H	44.6	60	40	155	-	-	-	-	-
713	N 45 × 2 × 21 × 9H	44.6	60	40	155	-	-	-	-	-
714	N 60 × 3 × 18 × 9H	59.4	80	55	195	N 60 × 3 × 18 × 9H	59.4	80	55	150
715	N 80 × 3 × 25 × 9H	79.4	90	65	210	N 80 × 3 × 25 × 9H	79.4	90	65	150
716	N 90 × 3 × 28 × 9H	89.4	120	85	220	N 100 × 3 × 32 × 9H	99.4	120	85	170
717	N 110 × 3 × 35 × 9H	109.4	120	90	220	N 110 × 3 × 35 × 9H	109.4	120	90	170
718	N 120 × 3 × 38 × 9H	119.4	140	105	255	N 120 × 3 × 38 × 9H	119.4	140	105	200
719	N 130 × 3 × 42 × 9H	129.4	140	105	255	N 130 × 3 × 42 × 9H	129.4	140	105	200
720	N 130 × 3 × 42 × 9H	129.4	150	115	290	N 140 × 3 × 45 × 9H	139.4	150	115	240
721	N 160 × 5 × 30 × 9H	159	150	115	290	N 160 × 5 × 30 × 9H	159	150	115	240
722	N 170 × 5 × 32 × 9H	169	180	145	345	N 170 × 5 × 32 × 9H	169	180	145	270
723	N 180 × 5 × 34 × 9H	179	180	145	345	N 180 × 5 × 34 × 9H	179	180	145	270
724	N 200 × 5 × 38 × 9H	199	200	160	390	N 200 × 5 × 38 × 9H	199	200	160	355
725	N 210 × 5 × 40 × 9H	209	200	160	390	N 210 × 5 × 40 × 9H	209	200	160	355

7.1.4. Flange shaft (F)

Size	D ₃	K ₂	D ₆	L ₁	L ₂	K × d ₂	M ₅	
							Gear Unit H2/H3/H4/B3/B4/C3/C4	Gear Unit B2
716	150H6	260	300	25	10	16 × 22	255	300
717	160H6	280	320	25	10	18 × 22	255	300
718	180H6	320	370	30	10	16 × 26	300	360
719	190H6	340	390	30	10	18 × 26	300	360
720	220H6	380	430	38	12	20 × 26	350	400
721	240H6	420	470	38	12	22 × 26	350	400
722	260H6	450	510	42	12	18 × 33	400	480
723	280H6	480	540	42	12	22 × 33	400	480
724	310H6	500	580	48	14	20 × 33	480	530
725	310H6	540	620	48	14	24 × 33	480	530

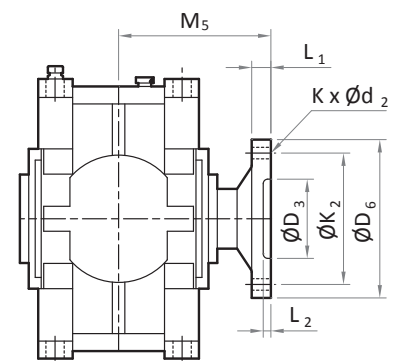

7.2 Hollow output shaft design with keyway (K)

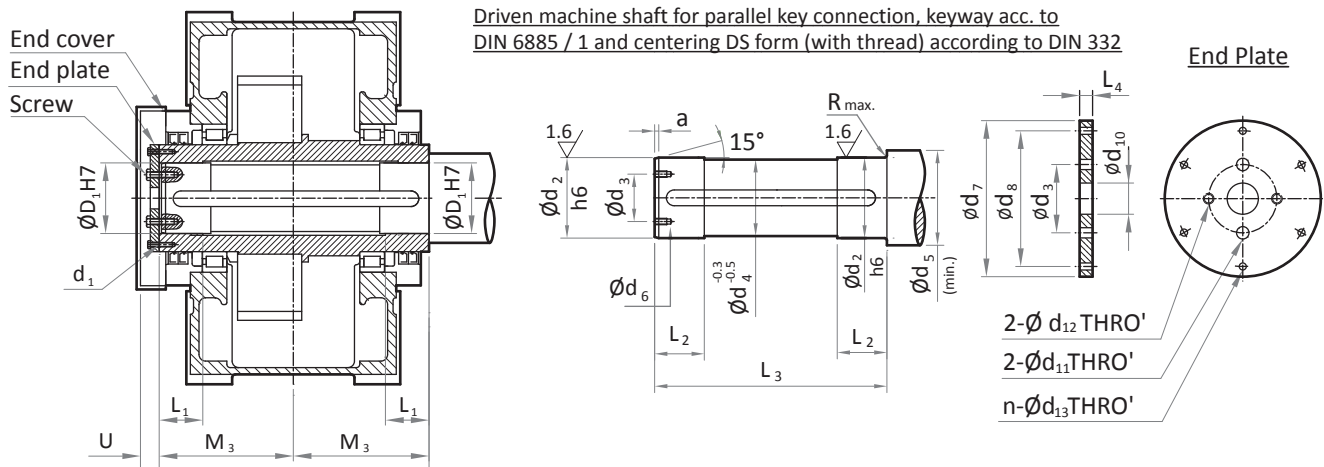

Driven machine shaft for parallel key connection, keyway acc. to DIN 6885 / 1 and centering DS form (with thread) according to DIN 332

Type : H2/H3/H4/B3/B4/C3/C4																							
Size	Hollow shaft					Driven machine shaft									End plate								
	D ₁	M ₃	L ₁	U	d ₁	d ₂	d ₄	d ₅	d ₃	d ₆	L ₂	L ₃	a	R	d ₁₀	d ₃	d ₈	d ₇	d ₁₁	d ₁₂	d ₁₃	n	L ₄
714	65	140	30	35	M6	65	65	75	44	M10	35	278	4	1.2	22	44	77.5	90	11	M10	6.6	4	10
715	80	140	30	35	M6	80	80	90	50	M10	35	278	4	1.2	22	50	95	110	11	M10	6.6	4	10
716	95	165	35	40	M6	95	95	105	60	M10	40	328	5	1.6	26	60	112	130	11	M10	6.6	4	10
717	105	165	40	40	M6	105	105	115	65	M10	45	328	5	1.6	26	65	122	140	11	M10	6.6	4	10
718	115	195	45	45	M8	115	115	125	75	M12	50	388	5	2.5	26	75	138	159	14	M12	9	4	12
719	125	195	50	45	M8	125	125	135	85	M12	55	388	6	2.5	26	85	148	169	14	M12	9	4	12
720	135	235	55	45	M8	135	135	150	90	M12	60	467	6	2.5	33	90	156	179	14	M12	9	4	12
721	150	235	60	45	M8	150	150	165	95	M12	65	467	6	2.5	33	95	175	199	14	M12	9	4	12
722	165	270	65	45	M10	165	165	180	100	M16	70	537	7	2.5	33	100	192	218	18	M16	11	6	15
723	180	270	70	45	M10	180	180	195	105	M16	75	537	7	2.5	33	105	210	238	18	M16	11	6	15
724	190	335	75	45	M10	190	190	210	115	M16	80	667	7	3	33	115	225	258	18	M16	11	6	18
725	210	335	80	45	M10	210	210	230	125	M16	85	667	8	3	33	125	245	278	18	M16	11	6	18

Type : B2																							
Size	Hollow shaft					Driven machine shaft									End plate								
	D ₁	M ₃	L ₁	U	d ₁	d ₂	d ₄	d ₅	d ₃	d ₆	L ₂	L ₃	a	R	d ₁₀	d ₃	d ₈	d ₇	d ₁₁	d ₁₂	d ₁₃	n	L ₄
714	65	175	30	35	M6	65	65	75	44	M10	35	348	4	1.2	22	44	77.5	90	11	M10	6.6	4	10
715	80	175	30	35	M6	80	80	90	50	M10	35	348	4	1.2	22	50	95	110	11	M10	6.6	4	10
716	95	200	35	40	M6	95	95	105	60	M10	40	398	5	1.6	26	60	112	130	11	M10	6.6	4	10
717	105	200	40	40	M6	105	105	115	65	M10	45	398	5	1.6	26	65	122	140	11	M10	6.6	4	10
718	115	250	45	40	M8	115	115	125	75	M12	50	498	5	2.5	26	75	138	159	14	M12	9	4	12
719	125	250	50	40	M8	125	125	135	85	M12	55	498	6	2.5	26	85	148	169	14	M12	9	4	12
720	135	280	55	45	M8	135	135	150	90	M12	60	557	6	2.5	33	90	156	179	14	M12	9	4	12
721	150	280	60	45	M8	150	150	165	95	M12	65	557	6	2.5	33	95	175	199	14	M12	9	4	12
722	165	340	65	45	M10	165	165	180	100	M16	70	677	7	2.5	33	100	192	218	18	M16	11	6	15
723	180	340	70	45	M10	180	180	195	105	M16	75	677	7	2.5	33	105	210	238	18	M16	11	6	15
724	190	375	75	55	M10	190	190	210	115	M16	80	747	7	3	33	115	225	258	18	M16	11	6	18
725	210	375	80	55	M10	210	210	230	125	M16	85	747	8	3	33	125	245	278	18	M16	11	6	18

Size	D ₁	B	Z	Tol. On Z
714	65	18	69.4	+0.2
715	80	22	85.4	
716	95	25	100.4	
717	105	28	111.4	
718	115	32	122.4	
719	125	32	132.4	
720	135	36	143.4	+0.3
721	150	36	158.4	
722	165	40	174.4	
723	180	45	190.4	
724	190	45	200.4	
725	210	50	221.4	

D ₁	Tol. Field	Tol.
65	H7	+0.030
80		
95		
105		+0.035
115		
125		
135	+0.040	
150		
165		
180	+0.046	
190		
210		

B	Tol. Field	Tol.
18	Js9	±0.022
22		
25		
28		±0.026
32		
32		
36	±0.031	
36		
40		
45		
45		
50		

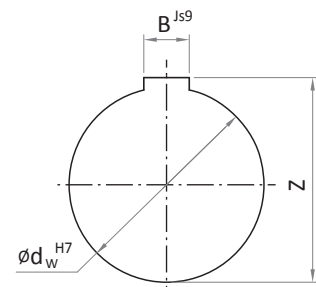

7.3 Standard hollow output shaft design with shrink disc (D)

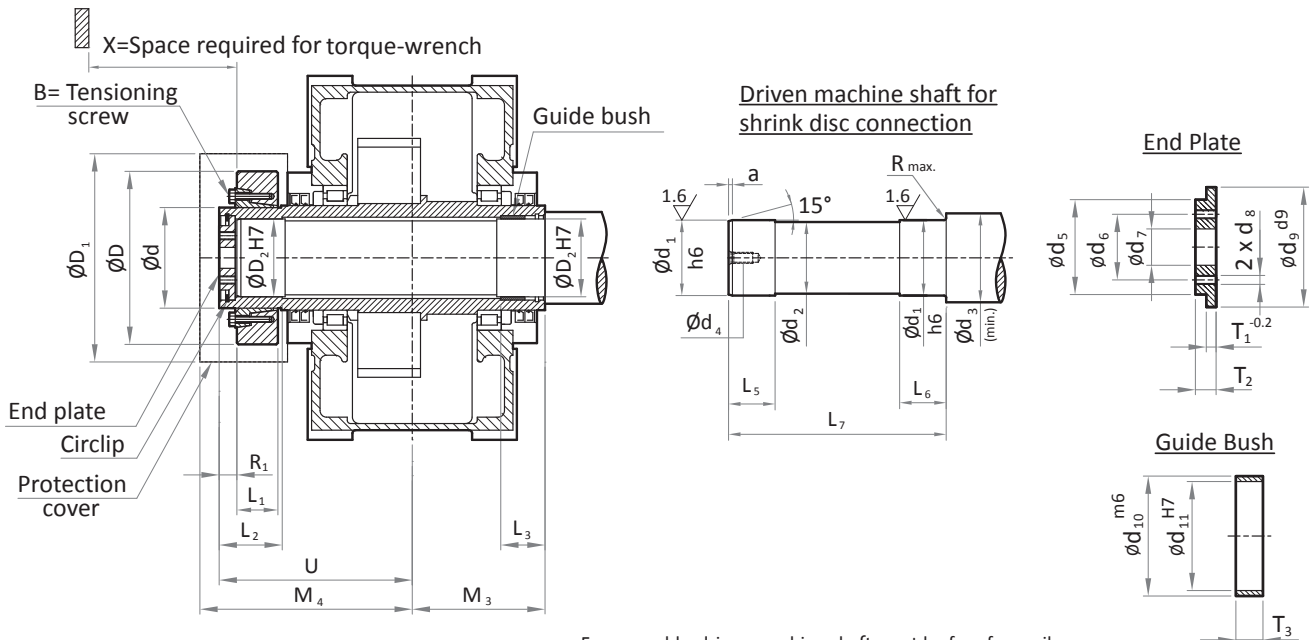

For assembly, driven machine shaft must be free from oil or grease
Driven machine shaft centering DS form (with thread) according to DIN 332

Type : H2/H3/H4/B3/B4/C3/C4																
Size	Hollow shaft						Shrink disc									
	D ₂	L ₂	L ₃	U	M ₃	R ₁	Type	D	d	D ₁	L ₁	M ₄	Mt (da Nm)	B	Ma (da Nm)	Weight kg.
714	65	60	50	205	140	20	90-65	155	90	188	35	225	650	M10	5.9	3.5
715	85	75	50	215	140	20	110-85	185	110	223	46	235	1610	M12	10	6.5
716	100	75	55	240	165	20	125-100	215	125	258	49	257	2330	M12	10	9
717	110	80	55	245	165	20	140-110	230	140	268	53	260	2800	M14	16	11
718	120	90	55	285	195	23	155-120	263	155	298	57	310	3760	M14	16	16
719	130	95	55	290	195	23	165-130	290	165	308	63	310	5300	M16	25	22
720	140	105	75	330	235	28	175-140	300	175	338	63	355	7000	M16	25	23
721	150	115	75	350	235	28	200-150	340	200	368	79	365	10500	M16	25	37
722	165	135	85	400	270	30	220-165	370	220	393	95	420	14200	M20	49	52
723	180	145	85	405	270	30	240-180	405	240	475	100	420	18900	M20	49	65
724	190	160	105	480	335	30	260-190	430	260	478	110	505	23300	M20	49	79
725	210	170	110	480	335	30	280-210	460	280	498	123	505	30700	M20	49	100

Type : H2/H3/H4/B3/B4/C3/C4																				
Size	Driven machine shaft								End plate							Guide bush				
	d ₁	d ₂	d ₃	R	L ₅	L ₆	L ₇	d ₄	a	d ₉	d ₅	d ₆	d ₇	d ₈	T ₁	T ₂	d ₁₁	d ₁₀	T ₃	Circlip
714	65	64.5	75	2	45	55	326	M20	4	70	50	35	22	M6	7	17	65	70	28	70 × 2.5
715	85	84.5	95	2	60	55	336	M20	4	90	70	50	22	M8	7	17	85	90	28	90 × 3
716	100	99.5	115	2	60	60	383	M24	5	105	80	55	26	M10	8	20	100	105	30	105 × 4
717	110	109.5	125	3	65	60	388	M24	5	115	85	60	26	M10	8	20	110	115	30	115 × 4
718	120	119.5	135	3	75	60	458	M24	5	125	90	65	26	M12	8	20	120	125	30	125 × 4
719	130	129.5	145	3	80	60	463	M24	6	135	100	70	26	M12	8	20	130	135	30	135 × 4
720	140	139.5	160	4	85	80	539	M30	6	145	110	80	33	M12	10	23	140	145	45	145 × 4
721	150	149.5	170	4	95	80	559	M30	6	155	120	90	33	M12	10	23	150	155	45	155 × 4
722	165	164.5	185	4	115	90	644	M30	7	170	130	90	33	M12	10	23	165	170	55	170 × 4
723	180	179.5	200	4	125	90	649	M30	7	185	140	100	33	M12	10	23	180	185	55	185 × 4
724	190	189.5	215	5	140	110	789	M30	7	195	150	110	33	M16	10	23	190	195	75	195 × 4
725	210	209.5	235	5	145	115	784	M30	8	215	170	130	33	M16	14	28	210	215	75	220 × 5

7.3 Standard hollow output shaft design with shrink disc (D)

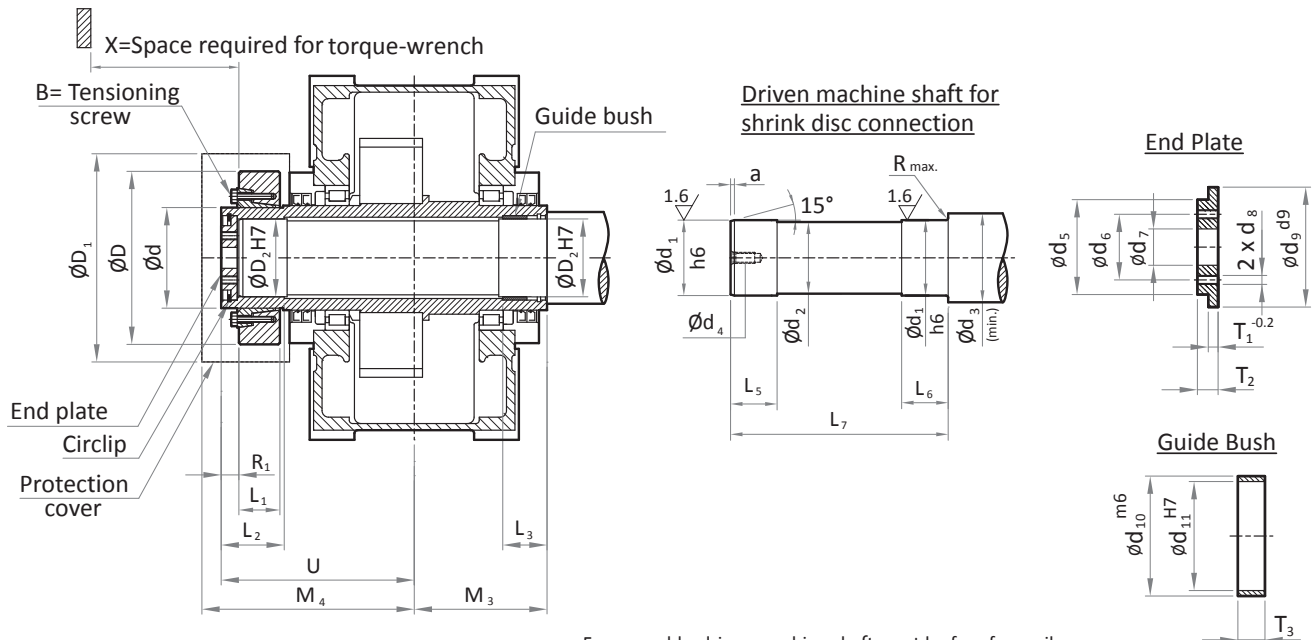

For assembly, driven machine shaft must be free from oil or grease
Driven machine shaft centering DS form (with thread) according to DIN 332

Type : B2																
Size	Hollow shaft						Shrink disc									
	D ₂	L ₂	L ₃	U	M ₃	R ₁	Type	D	d	D ₁	L ₁	M ₄	Mt (da Nm)	B	Ma (da Nm)	Weight kg.
714	65	60	50	240	175	20	90-65	155	90	188	35	260	650	M10	5.9	3.5
715	85	75	50	250	175	20	110-85	185	110	223	46	270	1610	M12	10	6.5
716	100	75	55	275	200	20	125-100	215	125	258	49	295	2330	M12	10	9
717	110	80	55	285	200	20	140-110	230	140	268	53	298	2800	M14	16	11
718	120	90	55	340	250	23	155-120	263	155	298	57	360	3760	M14	16	16
719	130	95	55	340	250	23	165-130	290	165	308	63	360	5300	M16	25	22
720	140	105	75	375	280	28	175-140	300	175	338	63	400	7000	M16	25	23
721	150	115	75	395	280	28	200-150	340	200	368	79	410	10500	M16	25	37
722	165	135	85	470	340	30	220-165	370	220	393	95	493	14200	M20	49	52
723	180	145	85	475	340	30	240-180	405	240	475	100	493	18900	M20	49	65
724	190	160	105	525	375	30	260-190	430	260	478	110	555	23300	M20	49	79
725	210	170	110	530	375	30	280-210	460	280	498	123	555	30700	M20	49	100

Type : B2																				
Size	Driven machine shaft								End plate							Guide bush				
	d ₁	d ₂	d ₃	R	L ₅	L ₆	L ₇	d ₄	a	d ₉	d ₅	d ₆	d ₇	d ₈	T ₁	T ₂	d ₁₁	d ₁₀	T ₃	Circlip
714	65	64.5	75	2	45	55	396	M20	4	70	50	35	22	M6	7	17	65	70	28	70 x 2.5
715	85	84.5	95	2	60	55	406	M20	4	90	70	50	22	M8	7	17	85	90	28	90 x 3
716	100	99.5	115	2	60	60	453	M24	5	105	80	55	26	M10	8	20	100	105	30	105 x 4
717	110	109.5	125	3	65	60	463	M24	5	115	85	60	26	M10	8	20	110	115	30	115 x 4
718	120	119.5	135	3	75	60	568	M24	5	125	90	65	26	M12	8	20	120	125	30	125 x 4
719	130	129.5	145	3	80	60	568	M24	6	135	100	70	26	M12	8	20	130	135	30	135 x 4
720	140	139.5	160	4	85	80	629	M30	6	145	110	80	33	M12	10	23	140	145	45	145 x 4
721	150	149.5	170	4	95	80	649	M30	6	155	120	90	33	M12	10	23	150	155	45	155 x 4
722	165	164.5	185	4	115	90	784	M30	7	170	130	90	33	M12	10	23	165	170	55	170 x 4
723	180	179.5	200	4	125	90	789	M30	7	185	140	100	33	M12	10	23	180	185	55	185 x 4
724	190	189.5	215	5	140	110	874	M30	7	195	150	110	33	M16	10	23	190	195	75	195 x 4
725	210	209.5	235	5	145	115	874	M30	8	215	170	130	33	M16	14	28	210	215	75	220 x 5

7.4 Alternate hollow output shaft design with shrink disc

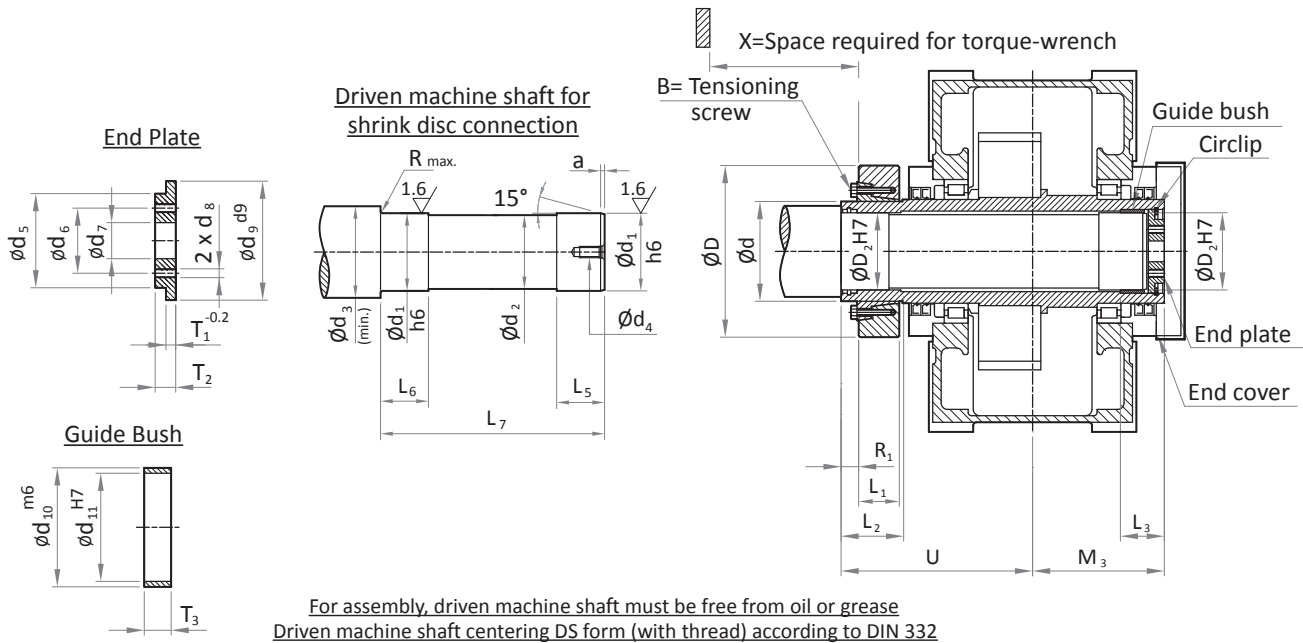

Type : H2/H3/H4/B3/B4/C3/C4														
Size	Hollow shaft						Shrink disc							
	D ₂	L ₂	L ₃	U	M ₃	R ₁	Type	D	d	L ₁	Mt (da Nm)	B	Ma (da Nm)	Weight kg.
714	65	60	50	205	140	20	90-65	155	90	35	650	M10	5.9	3.5
715	85	75	50	215	140	20	110-85	185	110	46	1610	M12	10	6.5
716	100	75	55	240	165	20	125-100	215	125	49	2330	M12	10	9
717	110	80	55	245	165	20	140-110	230	140	53	2800	M14	16	11
718	120	90	55	285	195	23	155-120	263	155	57	3760	M14	16	16
719	130	95	55	290	195	23	165-130	290	165	63	5300	M16	25	22
720	140	105	75	330	235	28	175-140	300	175	63	7000	M16	25	23
721	150	115	75	350	235	28	200-150	340	200	79	10500	M16	25	37
722	165	135	85	400	270	30	220-165	370	220	95	14200	M20	49	52
723	180	145	85	405	270	30	240-180	405	240	100	18900	M20	49	65
724	190	160	105	480	335	30	260-190	430	260	110	23300	M20	49	79
725	210	170	110	480	335	30	280-210	460	280	123	30700	M20	49	100

Type : H2/H3/H4/B3/B4/C3/C4																				
Size	Driven machine shaft								End plate							Guide bush				
	d ₁	d ₂	d ₃	R	L ₅	L ₆	L ₇	d ₄	a	d ₉	d ₅	d ₆	d ₇	d ₈	T ₁	T ₂	d ₁₁	d ₁₀	T ₃	Circlip
714	65	64.5	75	2	35	65	326	M20	4	70	50	35	22	M6	7	17	65	70	28	70 × 2.5
715	85	84.5	95	2	35	80	336	M20	4	90	70	50	22	M8	7	17	85	90	28	90 × 3
716	100	99.5	115	2	40	80	383	M24	5	105	80	55	26	M10	8	20	100	105	30	105 × 4
717	110	109.5	125	3	40	85	388	M24	5	115	85	60	26	M10	8	20	110	115	30	115 × 4
718	120	119.5	135	3	40	95	458	M24	5	125	90	65	26	M12	8	20	120	125	30	125 × 4
719	130	129.5	145	3	40	100	463	M24	6	135	100	70	26	M12	8	20	130	135	30	135 × 4
720	140	139.5	160	4	55	110	539	M30	6	145	110	80	33	M12	10	23	140	145	45	145 × 4
721	150	149.5	170	4	55	120	559	M30	6	155	120	90	33	M12	10	23	150	155	45	155 × 4
722	165	164.5	185	4	65	140	644	M30	7	170	130	90	33	M12	10	23	165	170	55	170 × 4
723	180	179.5	200	4	65	150	649	M30	7	185	140	100	33	M12	10	23	180	185	55	185 × 4
724	190	189.5	215	5	85	165	789	M30	7	195	150	110	33	M16	10	23	190	195	75	195 × 4
725	210	209.5	235	5	85	175	784	M30	8	215	170	130	33	M16	14	28	210	215	75	220 × 5

7.4 Alternate hollow output shaft design with shrink disc (D)

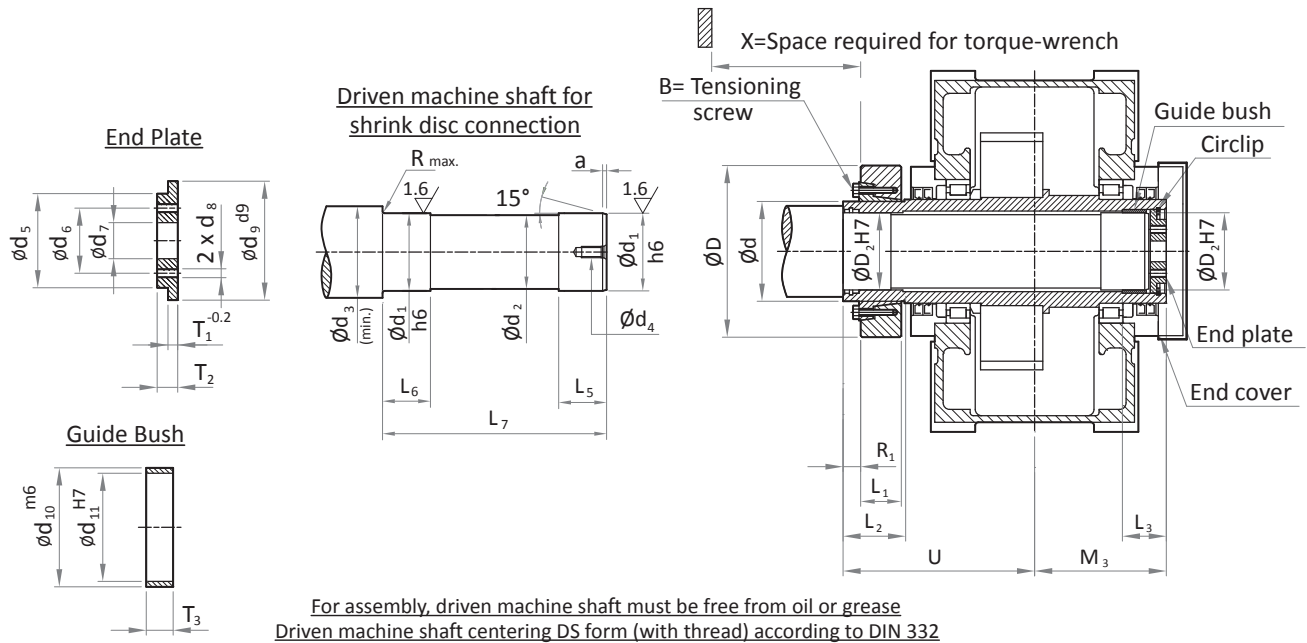

Type : B2														
Size	Hollow shaft						Shrink disc							
	D ₂	L ₂	L ₃	U	M ₃	R ₁	Type	D	d	L ₁	Mt (da Nm)	B	Ma (da Nm)	Weight kg.
714	65	60	50	240	175	20	90-65	155	90	35	650	M10	5.9	3.5
715	85	75	50	250	175	20	110-85	185	110	46	1610	M12	10	6.5
716	100	75	55	275	200	20	125-100	215	125	49	2330	M12	10	9
717	110	80	55	285	200	20	140-110	230	140	53	2800	M14	16	11
718	120	90	55	340	250	23	155-120	263	155	57	3760	M14	16	16
719	130	95	55	340	250	23	165-130	290	165	63	5300	M16	25	22
720	140	105	75	375	280	28	175-140	300	175	63	7000	M16	25	23
721	150	115	75	395	280	28	200-150	340	200	79	10500	M16	25	37
722	165	135	85	470	340	30	220-165	370	220	95	14200	M20	49	52
723	180	145	85	475	340	30	240-180	405	240	100	18900	M20	49	65
724	190	160	105	525	375	30	260-190	430	260	110	23300	M20	49	79
725	210	170	110	530	375	30	280-210	460	280	123	30700	M20	49	100

Type : B2																				
Size	Driven machine shaft								End plate							Guide bush				
	d ₁	d ₂	d ₃	R	L ₅	L ₆	L ₇	d ₄	a	d ₉	d ₅	d ₆	d ₇	d ₈	T ₁	T ₂	d ₁₁	d ₁₀	T ₃	Circlip
714	65	64.5	75	2	35	65	396	M20	4	70	50	35	22	M6	7	17	65	70	28	70 × 2.5
715	85	84.5	95	2	35	80	406	M20	4	90	70	50	22	M8	7	17	85	90	28	90 × 3
716	100	99.5	115	2	40	80	453	M24	5	105	80	55	26	M10	8	20	100	105	30	105 × 4
717	110	109.5	125	3	40	85	463	M24	5	115	85	60	26	M10	8	20	110	115	30	115 × 4
718	120	119.5	135	3	40	95	568	M24	5	125	90	65	26	M12	8	20	120	125	30	125 × 4
719	130	129.5	145	3	40	100	568	M24	6	135	100	70	26	M12	8	20	130	135	30	135 × 4
720	140	139.5	160	4	55	110	629	M30	6	145	110	80	33	M12	10	23	140	145	45	145 × 4
721	150	149.5	170	4	55	120	649	M30	6	155	120	90	33	M12	10	23	150	155	45	155 × 4
722	165	164.5	185	4	65	140	784	M30	7	170	130	90	33	M12	10	23	165	170	55	170 × 4
723	180	179.5	200	4	65	150	789	M30	7	185	140	100	33	M12	10	23	180	185	55	185 × 4
724	190	189.5	215	5	85	165	874	M30	7	195	150	110	33	M16	10	23	190	195	75	195 × 4
725	210	209.5	235	5	85	175	874	M30	8	215	170	130	33	M16	14	28	210	215	75	220 × 5

7.5 Hollow output shaft design with spline (S)

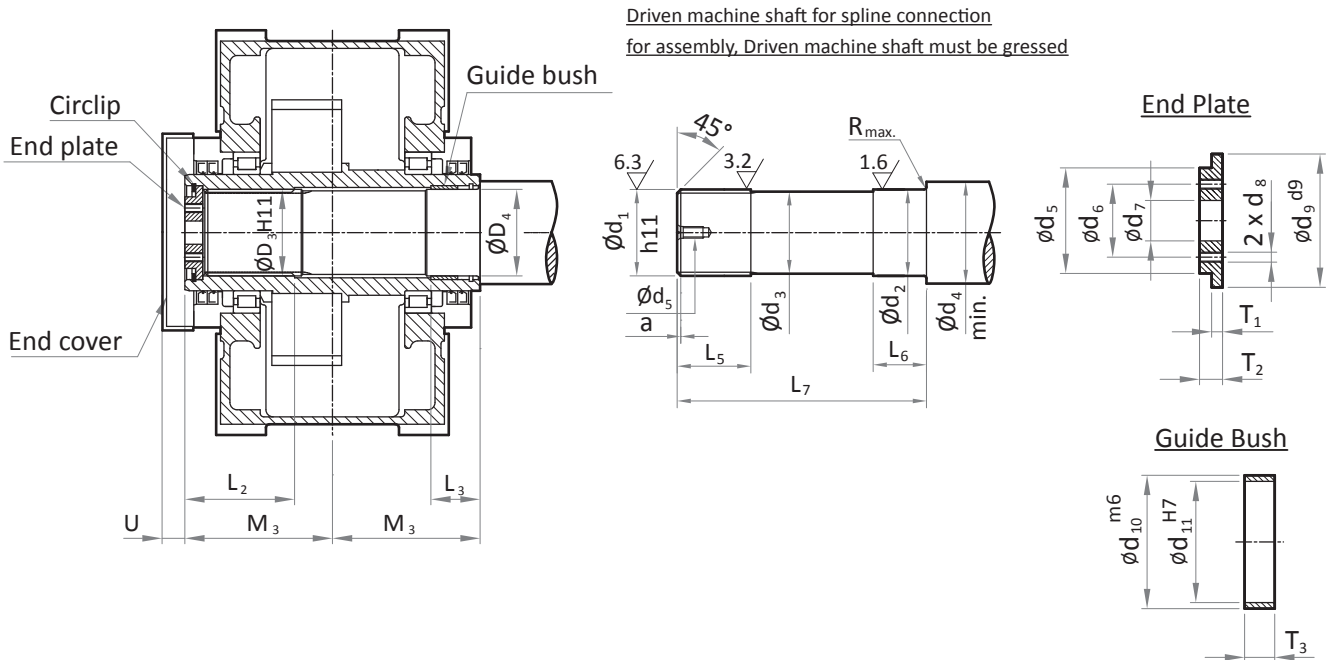

Driven machine shaft for spline connection
for assembly, Driven machine shaft must be gressed

Type : H2/H3/H4/B3/B4/C3/C4															
Size	Driven machine shaft											Guide bush			
	External Spline DIN 5480	d ₁	d ₂	d ₃	d ₄	d ₅	a	L ₇	L ₆	L ₅	R	d ₁₁	d ₁₀	T ₃	Circlip
716	W95 x 3 x 30 x 8f	94.4	100 h6	93	115	M24	3	308	52	90	2	100	105	30	105x4
717	W95 x 3 x 30 x 8f	94.4	100 h6	93	115	M24	3	308	52	90	3	100	105	30	105x4
718	W120 x 3 x 38 x 8f	119.4	120 h6	118	135	M24	3	368	67	105	3	120	125	30	125x4
719	W120 x 3 x 38 x 8f	119.4	120 h6	118	135	M24	3	368	67	105	3	120	125	30	125x4
720	W140 x 3 x 45 x 8f	139.4	145 m6	138	160	M30	3	444	82	126	4	145	150	45	145x4
721	W140 x 3 x 45 x 8f	139.4	145 m6	138	160	M30	3	444	82	126	4	145	150	45	145x4
722	W170 x 5 x 32 x 8f	169	170 m6	168	185	M30	5	514	112	155	4	170	175	55	175x4
723	W170 x 5 x 32 x 8f	169	170 m6	168	185	M30	5	514	112	155	4	170	175	55	175x4
724	W190 x 5 x 36 x 8f	189	195 m6	188	215	M30	5	644	137	180	5	195	200	75	195x4
725	W190 x 5 x 36 x 8f	189	195 m6	188	215	M30	5	644	137	180	5	195	200	75	195x4

Type : H2/H3/H4/B3/B4/C3/C4													
Size	Hollow shaft						End plate						
	D ₃	D ₄	L ₂	L ₃	M ₃	U	T ₁	T ₂	d ₉	d ₅	d ₇	d ₆	2 x d ₈
716	89	100	110	55	165	40	8	20	105	80	26	55	M10
717	89	100	110	55	165	40	8	20	105	80	26	55	M10
718	114	120	125	70	195	45	8	20	125	90	26	65	M12
719	114	120	125	70	195	45	8	20	125	90	26	65	M12
720	134	145	150	85	235	45	10	23	145	110	33	80	M12
721	134	145	150	85	235	45	10	23	145	110	33	80	M12
722	160	170	175	115	270	45	10	23	175	135	33	95	M12
723	160	170	175	115	270	45	10	23	175	135	33	95	M12
724	180	195	210	140	335	45	10	23	195	150	33	110	M16
725	180	195	210	140	335	45	10	23	195	150	33	110	M16

7.5 Hollow Output Shaft Design with Spline (S)

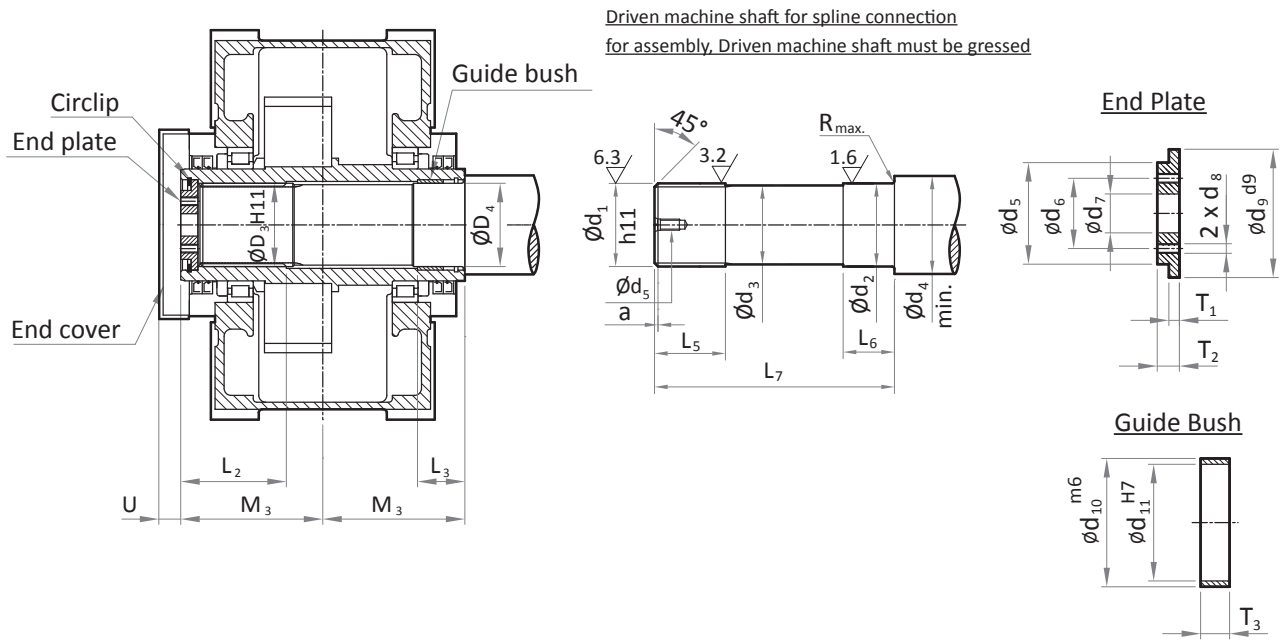

Driven machine shaft for spline connection
for assembly, Driven machine shaft must be gressed

Type : B2															
Size	Driven machine shaft											Guide bush			
	External Spline DIN 5480	d ₁	d ₂	d ₃	d ₄	d ₅	a	L ₇	L ₆	L ₅	R	d ₁₁	d ₁₀	T ₃	Circlip
716	W95 x 3 x 30 x 8f	94.4	100 h6	93	115	M24	3	378	52	90	2	100	105	30	105x4
717	W95 x 3 x 30 x 8f	94.4	100 h6	93	115	M24	3	378	52	90	3	100	105	30	105x4
718	W120 x 3 x 38 x 8f	119.4	120 h6	118	135	M24	3	478	67	105	3	120	125	30	125x4
719	W120 x 3 x 38 x 8f	119.4	120 h6	118	135	M24	3	478	67	105	3	120	125	30	125x4
720	W140 x 3 x 45 x 8f	139.4	145 m6	138	160	M30	3	534	82	126	4	145	150	45	145x4
721	W140 x 3 x 45 x 8f	139.4	145 m6	138	160	M30	3	534	82	126	4	145	150	45	145x4
722	W170 x 5 x 32 x 8f	169	170 m6	168	185	M30	5	654	112	155	4	170	175	55	175x4
723	W170 x 5 x 32 x 8f	169	170 m6	168	185	M30	5	654	112	155	4	170	175	55	175x4
724	W190 x 5 x 36 x 8f	189	195 m6	188	215	M30	5	724	137	180	5	195	200	75	195x4
725	W190 x 5 x 36 x 8f	189	195 m6	188	215	M30	5	724	137	180	5	195	200	75	195x4

Type : B2													
Size	Hollow shaft						End plate						
	D ₃	D ₄	L ₂	L ₃	M ₃	U	T ₁	T ₂	d ₉	d ₅	d ₇	d ₆	2 x d ₈
716	89	100	110	55	200	40	8	20	105	80	26	55	M10
717	89	100	110	55	200	40	8	20	105	80	26	55	M10
718	114	120	125	70	250	40	8	20	125	90	26	65	M12
719	114	120	125	70	250	40	8	20	125	90	26	65	M12
720	134	145	150	85	280	45	10	23	145	110	33	80	M12
721	134	145	150	85	280	45	10	23	145	110	33	80	M12
722	160	170	175	115	340	45	10	23	175	135	33	95	M12
723	160	170	175	115	340	45	10	23	175	135	33	95	M12
724	180	195	210	140	375	55	10	23	195	150	33	110	M16
725	180	195	210	140	375	55	10	23	195	150	33	110	M16

7.6 Counter Flange detail for Flange Output Shaft

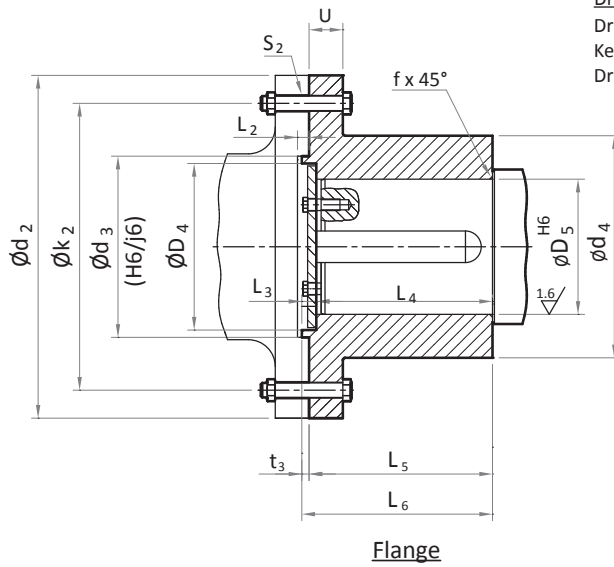

Driven machine shaft for Key connection.

Driven machine shaft for parallel key connection,

Keyway according to DIN:6885/1

Driven machine shaft with tapped centre hole acc. to DIN 332.

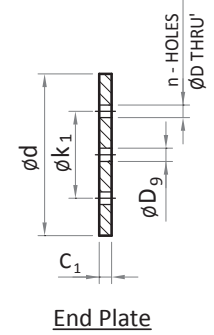
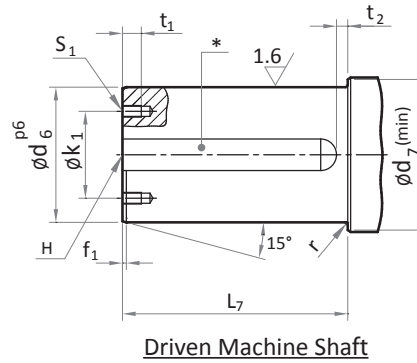

* Single Keyway for sizes 716-721

Double Keyway at 180° for sizes 722-725

Size	Flange details														Bolt size		
	D ₆	d ₃	d ₄	D ₅	f	K ₂	L ₂	L ₃	L ₄	L ₅	t ₃	L ₆	U	D ₄	S ₂	QTY.	Torque Nm.
716	300	150	190	110	2.5	260	15	17	166	175	8	183	25	135	M20 x 70	16	610
717	320	160	210	120	2.5	280	15	22	171	185	8	193	25	145	M20 x 70	18	610
718	370	180	230	135	2.5	320	15	22	206	220	8	228	30	160	M24 x 90	16	1050
719	390	190	270	150	2.5	340	15	22	206	220	8	228	30	175	M24 x 90	18	1050
720	430	220	290	160	4	380	20	22	238	250	10	260	36	195	M24 x 100	20	1050
721	470	240	310	180	4	420	20	22	238	250	10	260	36	220	M24 x 100	22	1050
722	510	260	340	200	4	450	20	28	272	290	10	300	42	235	M30 x 120	18	2100
723	540	280	360	210	4	480	20	28	272	290	10	300	42	255	M30 x 120	22	2100
724	580	310	390	240	6	500	25	28	325	341	12	353	46	285	M30 x 130	20	2100
725	620	310	425	260	6	540	25	28	360	376	12	388	46	285	M30 x 130	24	2100

Size	Driven machine shaft details									
	d ₆	K ₁	H	S ₁	t ₁	t ₂	d ₇	f ₁	r	L ₇
716	110	80	M24	M12	28	7.5	122	2.5	2	164
717	120	95	M24	M16	32	7.5	132	2.5	2	169
718	135	95	M30	M16	32	16	147	2.5	2	204
719	150	110	M30	M16	32	16	162	2.5	2	204
720	160	110	M30	M16	32	16	176	4	3	235
721	180	145	M30	M20	38	16	196	4	3	235
722	200	145	M30	M20	38	16	216	4	3	269
723	210	160	M30	M20	38	16	230	4	3	269
724	240	185	M36	M20	38	16	260	4	3	322
725	260	205	M36	M20	38	16	280	4	3	357

Size	End plate details					
	d	K ₁	C ₁	D	D ₉	n
716	130	80	10	14	27	4
717	140	95	14	18	27	4
718	155	95	14	18	33	4
719	170	110	14	18	33	4
720	190	110	14	18	33	4
721	215	145	14	18	33	4
722	230	145	18	23	33	4
723	250	160	18	23	33	4
724	280	185	18	23	39	4
725	300	205	18	23	39	4

D ₅	B	Z	Z ₁	Tol.on Z
110	28	116.4		+0.2
120	32	127.4		
135	36	143.4		
150	36	158.4		
160	40	169.4		
180	45	190.4		
200	45	210.4	220.8	+0.3
210	50	221.4	232.8	
240	56	252.4	264.8	
260	56	272.4	284.8	

D ₅	Tol. Field	Tol.
110		+0.022
120		
135		
150		+0.025
160		
180		
200		
210		
240		+0.029
260		

D ₅	Tol. Field	Tol.
28		+0.026 -0.026
32		
36		
40	Js9	+0.031 -0.031
50		
56		+0.037 -0.037

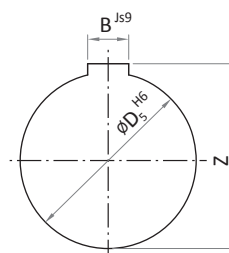

Size : 716-721

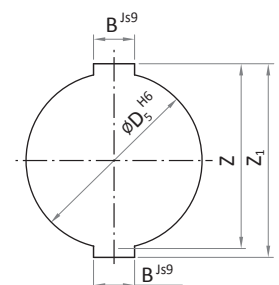

Size : 722-725

7.7 Permissible additional forces at output shaft (F_R)

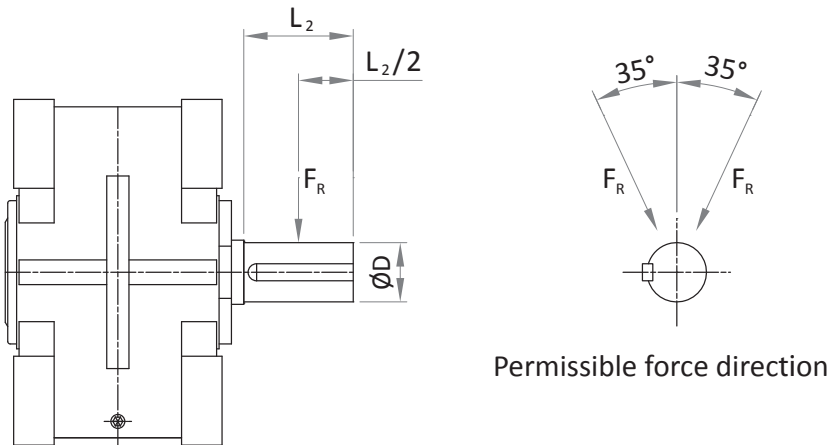

Size	Type											
	H2		H3		H4		B2		B3		B4	
	Handing											
	11,13,19,21	15,17	11,13,19,21	15,17	11,13,19,21	15,17	11,13	15,17	11,13	15,17	11,13	15,17
Permissible additional forces in kN												
715	9	9	-	-	-	-	12	11	13	8	-	-
716	20	12	27	17	-	-	25	14	27	17	27	17
717	20	12	27	17	-	-	25	14	27	17	27	17
718	28	17	37	24	24	38	35	15	38	25	38	25
719	28	17	37	24	24	38	35	15	38	25	38	25
720	28	24	37	24	24	38	35	24	38	24	38	24
721	42	26	55	38	38	57	50	28	57	38	57	38
722	60	33	80	47	47	80	74	30	80	45	80	45
723	60	33	80	47	47	80	74	35	80	45	80	45
724	142	105	180	140	140	180	150	105	180	140	180	140
725	142	105	180	140	140	180	150	105	180	140	180	140

OVERHUNG LOADS :

Whenever a sprocket, gear, sheave or pulley is mounted on the output shaft, a calculation should be made to determine the overhung load in Newtons on the shaft, using the formula

$$P = \frac{kW \times 9550 \times K}{N \times R}$$

Where, P = equivalent overhung load in Newtons
 kW = power carried by shaft in Kilo Watts
 N = r.p.m. of the shaft
 R = pitch radius of sprocket, pinion, sheave or pulley in meter
 K = factor

Overhung Member	K Factor
Sprocket	1
Spur Pinion	1.25
V-belt Sheave	1.5
Flat Belt Pulley	2

The calculated equivalent overhung load should be compared with the permissible values given in the table



OPTIONS FOR ADD ON PARTS

- 8.1 Additional intermediate shaft extension details
- 8.2 Protection cover details
- 8.3 Cooling coil details
- 8.4 Heater details
- 8.5 Force lubrication details
- 8.6 Torque arm details
- 8.7 Motor mounting adaptor details
- 8.8 Mounting flange (Output shaft side)
- 8.9 Shaft center details

8.1 Additional intermediate shaft extension details

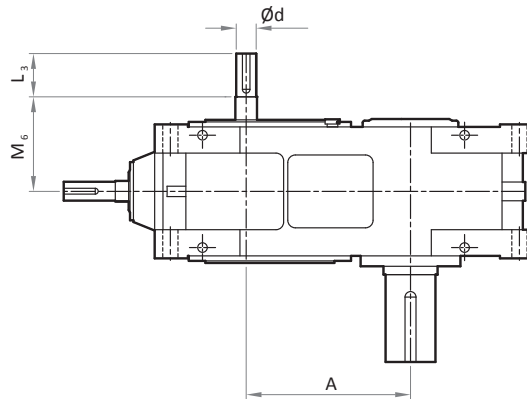

Size	Type : B2					
	i = 5 - 22.4					
	A	M ₆	d	L ₃	d	L ₃
714	130	195	42	100	32 ¹⁾²⁾	90
715	160	195	55	120	42 ¹⁾⁶⁾	100
716	186	225	55	120	45 ¹⁾⁴⁾	110
717	205	225	55	120	45 ¹⁾³⁾	110
718	232	265	70	150	60 ¹⁾⁵⁾	130
719	263	265	70	150	60 ¹⁾³⁾	130
720	270	300	90	170	70 ¹⁾⁵⁾	150
721	290	300	90	170	70 ¹⁾³⁾	150
722	328	360	100	190	100	190
723	384	360	100	190	100	190
724	376	390	120	210	120	210
725	445	390	120	210	120	210

- 1) Extn dia suitable For shaft arrangement LRR, RLL, RRL, LLR
- 2) i = 14
- 3) i = 7.1, 8, 10, 11.2, 14, 16, 20, 22.4
- 4) i = 6.3, 9, 12.5, 14, 18, 20
- 5) i = 6.3, 7.1, 9, 10, 12.5, 14, 18, 20
- 6) i = 6.3 to 22.4

Size	Type : B3/C3					
	i = 12.5 - 71					
	i = 16 - 90					
	A	M ₆	d	L ₃	d	L ₃
714	232	170	30	85	22 ¹⁾²⁾	80
715	259	170	30	85	22 ¹⁾³⁾	80
716	315	180	38	90	38	90
717	352	180	38	90	38	90
718	395	205	45	110	35 ¹⁾⁴⁾	90
719	444	205	45	110	35 ¹⁾⁵⁾	90
720	453	250	55	120	55	120
721	502	250	55	120	55	120
722	556	285	70	150	55 ¹⁾⁶⁾	120
723	617	285	70	150	55 ¹⁾⁷⁾	120
724	647	345	85	160	70 ¹⁾⁶⁾	150
725	712	345	85	160	70 ¹⁾⁷⁾	150

- 1) Extn dia suitable For shaft arrangement LRR, RLL, RRL, LLR, LDR, RDL
- 2) i = 22.4, 25, 31.5, 35.5, 45, 50, 63, 71
- 3) i = 28, 31.5, 40, 45, 56, 63, 80, 90
- 4) i = 25, 28, 35.5, 40, 50, 71
- 5) i = 31.5, 35.5, 45, 50, 63, 90
- 6) i = 25, 35.5, 50, 71
- 7) i = 31.5, 45, 63, 90

Size	Type : B4/C4					
	i = 80 - 355					
	i = 100 - 450					
	A	M ₆	d	L ₃	d	L ₃
716	315	180	38	90	38	90
717	352	180	38	90	38	90
718	395	205	45	110	35 ¹⁾²⁾	90
719	444	205	45	110	35 ¹⁾³⁾	90
720	453	250	55	120	55	120
721	502	250	55	120	55	120
722	556	285	70	150	55 ¹⁾⁴⁾	120
723	617	285	70	150	55 ¹⁾⁵⁾	120
724	647	345	85	160	70 ¹⁾⁴⁾	150
725	712	345	85	160	70 ¹⁾⁵⁾	150

- 1) Extn dia suitable For shaft arrangement RRR, LLL, LRL, RLR, RDR, LDL
- 2) i = 100, 112, 140, 160, 200, 224, 280, 315, 355
- 3) i = 125, 140, 180, 200, 250, 280, 355, 400, 450
- 4) i = 112, 160, 315
- 5) i = 140, 200, 400

8.2 Protection cover details

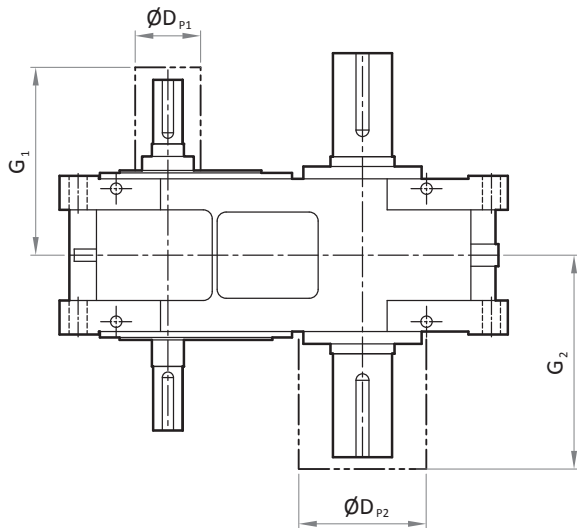

H2/H3/H4 Input & Output

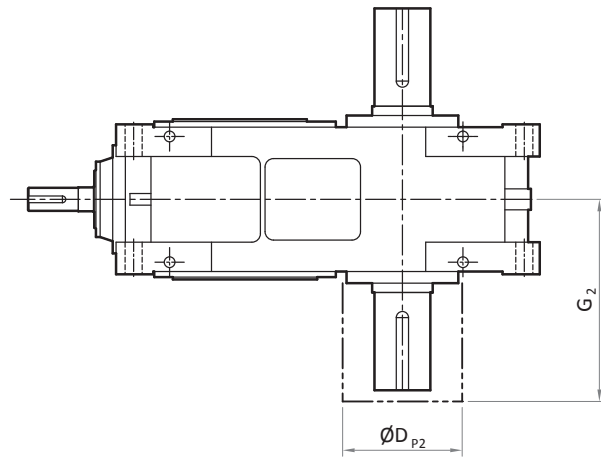

B2/B3/B4/C3&C4 Output

Size	H2 Input		H3 Input		H4 Input		H2/H3/H4/B3/B4/C3/C4 Output		B2 Output	
	D _{P1}	G ₁	D _{P1}	G ₁	D _{P1}	G ₁	D _{P2}	G ₂	D _{P2}	G ₂
712	-	-	-	-	-	-	-	-	145	265
713	-	-	-	-	-	-	-	-	145	265
714	115	290	105	275	-	-	195	300	195	335
715	115	290	105	275	-	-	230	355	230	390
716	150	365	115	330	95	260	265	400	265	440
717	150	365	115	330	95	260	265	410	265	450
718	165	365	120	330	105	295	275	430	300	485
719	165	365	120	330	105	295	295	465	295	515
720	185	435	160	430	115	365	310	510	345	560
721	185	435	160	430	115	365	355	565	355	610
722	215	475	165	460	115	375	375	595	375	665
723	215	475	165	460	115	375	390	635	390	705
724	225	555	195	520	150	485	460	700	460	760
725	225	555	195	520	150	485	460	710	460	760

8.3 Cooling coil details

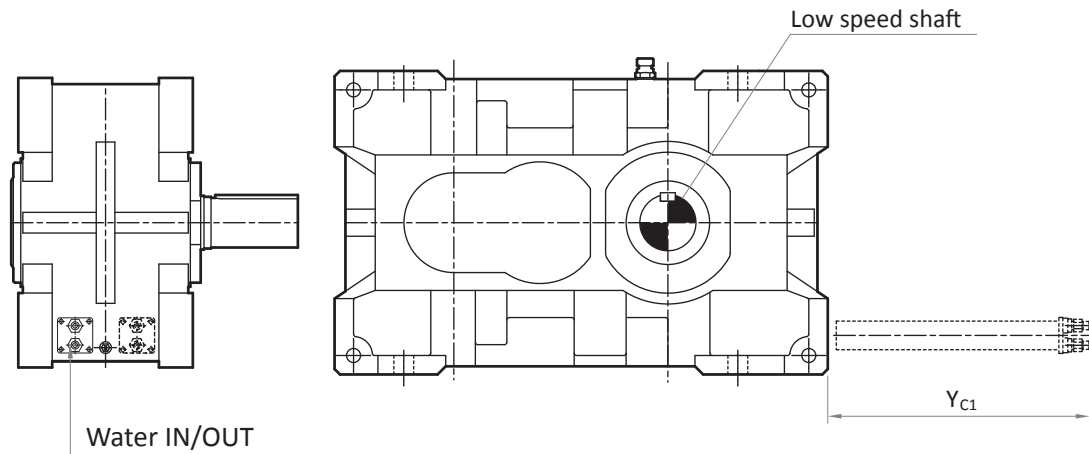

Size	Type:- H1/B2		
	Water IN & OUT connection	Req. LPM	Y _{C1}
712 - 713	On Request		
714 - 715	On Request		
716 - 717	3/8" BSP	6	-
718 - 719	1/2" BSP	6	550
720 - 721	1/2" BSP	12	550
722 - 723	1/2" BSP	12	600
724 - 725	1/2" BSP	12	600

Size	Type:- H2/H3/H4/B3/B4/C3/C4		
	Water IN & OUT connection	Req. LPM	Y _{C1}
714 - 715	On Request		
716 - 717	3/8" BSP	6	-
718 - 719	3/8" BSP	6	550
720 - 721	1/2" BSP	6	550
722 - 723	1/2" BSP	12	600
724 - 725	1/2" BSP	12	600

- Shown cooling coils position is for horizontal mounting only. For other mounting position contact us.
- The efficiency of a cooling coil depends on the quality of the cooling medium used.
- Built-in cooling coils of normal design suitable for fresh water.
(mains and recirculated water not to be chemically polluted)
- Maximum permissible pressure of water : 8 bar
- Water inlet & outlet connections are interchangeable.
- Sea water and brackish water require cooling coils of special design

Requirements on the water quality

- The water quality requirements listed below are suggestions. In exceptional cases, certain concentrations of substances in the content might cause unforeseen reactions.
- The quality of the water as well as its substances are important factors for assessing the cooling water available for water cooling coil / heat exchanger.
- Water hardness and pH levels are key factors in determining the quality of the water.

Identify quality limits for water in contact with the cooling coil / heat exchanger

Element/compound/property	Value/unit
pH	6.0 - 9.0
Conductivity	< 500 μS/cm
Total Hardness	4.5 - 8.5 dH°
Free Chlorine	< 1.0 ppm
Ammonia (NH ₃)	< 0.5 ppm
Sulphate (SO ₄ ²⁻)	< 100 ppm
Hydrogen carbonate (HCO ₃ ⁻)	60 - 200 ppm
(HCO ₃ ⁻) / (SO ₄ ²⁻)	> 1.5
(Ca + Mg) / (HCO ₃ ⁻)	> 0.5
Chloride (Cl ⁻)	< 25000 ppm

8.4 Heater details

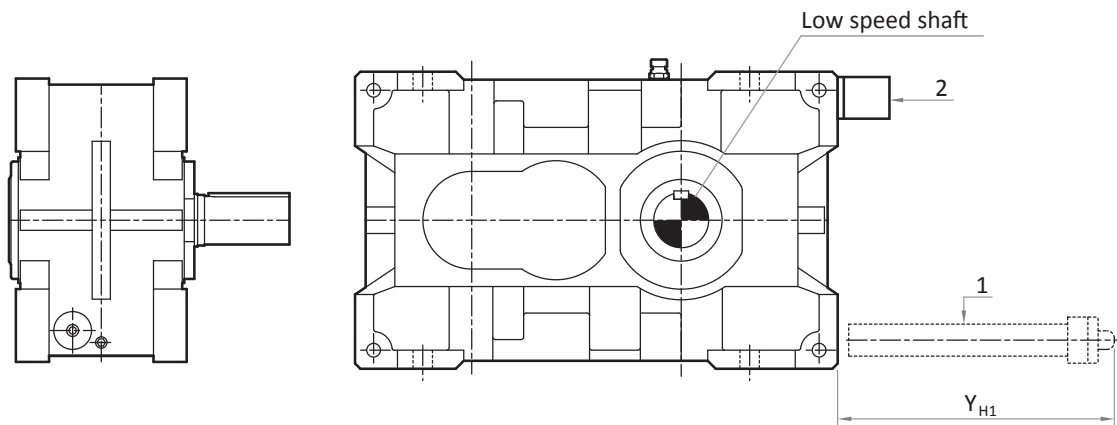

Size	Heater power, Watt	Installation space 'Y _{H1} ' in mm
712 - 713	On Request	On Request
714 - 715	255	350
716 - 717	450	450
718 - 719	600	520
720 - 721	750	590
722 - 723	900	690
724 - 725	1500	840

1 - Heating element
2 - Thermostat

Gear unit oil needs to be heated up when the minimum oil temperature is undershot. The gear unit oil must be heated at the client's end using the appropriate method in order to obtain the required oil temperature.

Thermostat or RTD is used to turn on and off the heating element. When the oil temperature exceeds limiting value, the heating system must be turned off. Set trip temperature on thermostat according to lubricant used. The heating element is supplied with a thermowell, so it can be replaced without draining off the gear unit oil.

Technical Specification :

- Voltage : 230 VAC
- Watt Density : 1.5 W/cm² (Max.)

$$\text{Start up time(Hr)} = \frac{\text{weight of oil (kg)} \times (\text{Abm. temperature} - \text{Req. temperature } ^\circ\text{C}) \times \text{specific heat of oil (kJ/kg}^\circ\text{C)}}{3600 \times \text{Heater power (Watt)}}$$

Temperature Limit without heating element :

Approximate temperature limits for different viscosity classes at following:

Oil viscosity class	Splash lubrication		Pressure lubrication
	Mineral oil	Synthetic oil	Mineral oil / Synthetic oil
ISO VG 150	-15 °C	-35 °C	> +20 °C
ISO VG 220	-10 °C	-30 °C	> +25 °C
ISO VG 320	-10 °C	-30 °C	> +25 °C
ISO VG 460	-5 °C	-25 °C	> +30 °C

Note :

- Shown cooling coils position is for horizontal mounting only. For other mounting position contact us.
- Oil viscosity class is selected by ELECON and marked on gear box name plate.

8.5 Force lubrication details

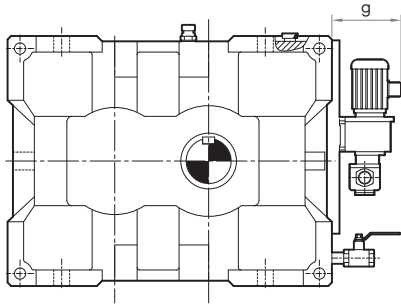

Size	Type: H1/B2, Horizontal mounting	
	Motor driven pump dimensions	
	g ¹⁾	
716 - 717	400	
718 - 719	400	
720 - 721	400	
722 - 723	450	
724 - 725	450	

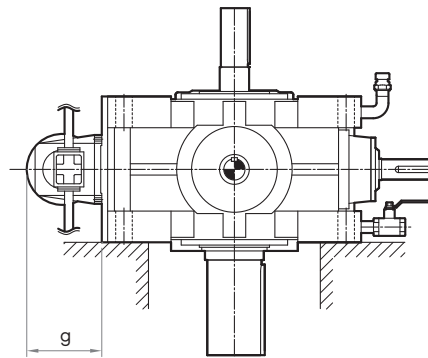

Size	Vertical mounting gear unit	
	Motor driven pump dimensions	
	g ¹⁾	
712 - 713	-	
714 - 715	400	
716 - 717	400	
718 - 719	400	
720 - 721	400	
722 - 723	400	
724 - 725	450	

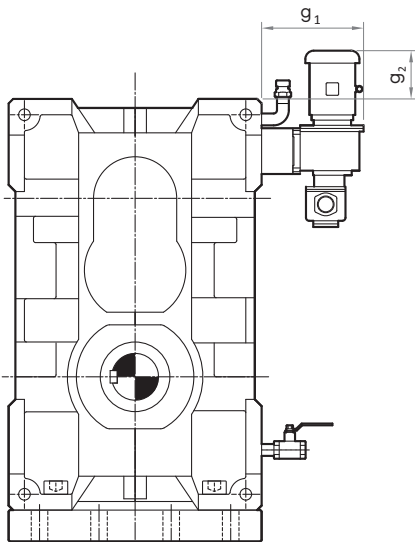

Size	Over driven mounting gear unit	
	Motor driven pump dimensions	
	g ₁ ¹⁾	g ₂ ¹⁾
714 - 715	500	175
716 - 717	500	150
718 - 719	500	120
720 - 721	500	100
722 - 723	500	75
724 - 725	550	75

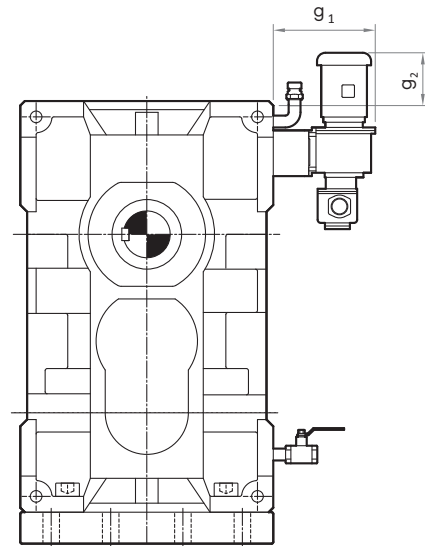

Size	Under driven mounting gear unit	
	Motor driven pump dimensions	
	g ₁ ¹⁾	g ₂ ¹⁾
714 - 715	500	175
716 - 717	500	150
718 - 719	500	120
720 - 721	500	100
722 - 723	500	75
724 - 725	550	75

1) Approximate values

- Accessories or piping are only for illustration purpose, the actual product may be differ.
- Accessories is shown without piping.

8.5 Force lubrication with cooler details

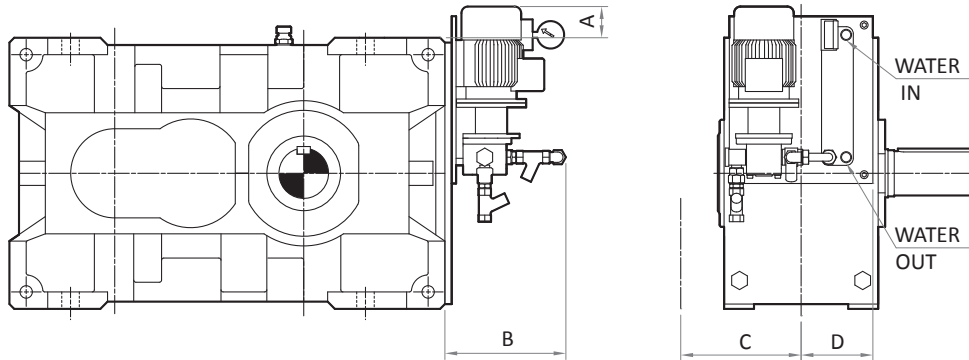

Size	Horizontal gear unit			
	Additional cooling system dimensions (with water cooler)			
	A ¹⁾	B ¹⁾	C ¹⁾	D ¹⁾
714 - 715	175	450	300	200
716 - 717	150	450	300	200
718 - 719	100	450	300	200
720 - 721	175	450	325	225
722 - 723	75	450	325	240
724 - 725	50	450	350	280

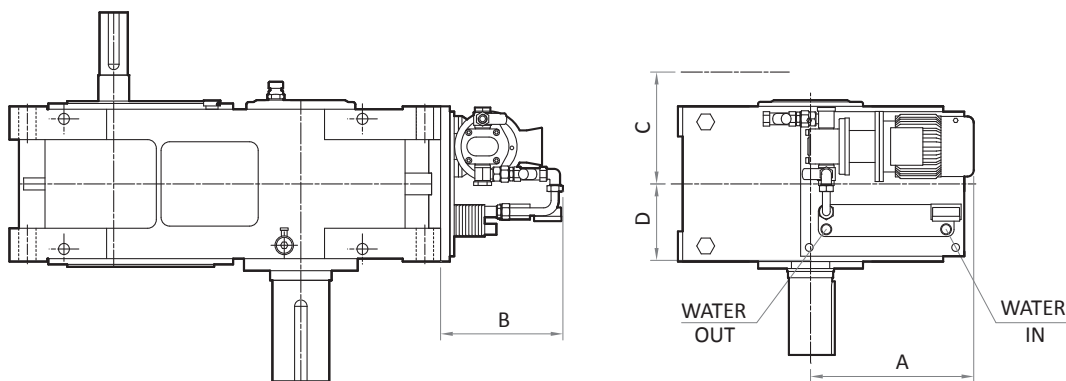

Size	Vertical gear unit			
	Additional cooling system dimensions (with water cooler)			
	A ¹⁾	B ¹⁾	C ¹⁾	D ¹⁾
714 - 715	375	450	300	200
716 - 717	350	450	300	200
718 - 719	325	450	300	200
720 - 721	500	450	325	225
722 - 723	450	450	325	240
724 - 725	440	450	350	280

- Accessories or piping are only for illustration purpose, the actual product may differ.
- Accessories is shown without piping.

1) Approximate values

8.5 Force lubrication with cooler details

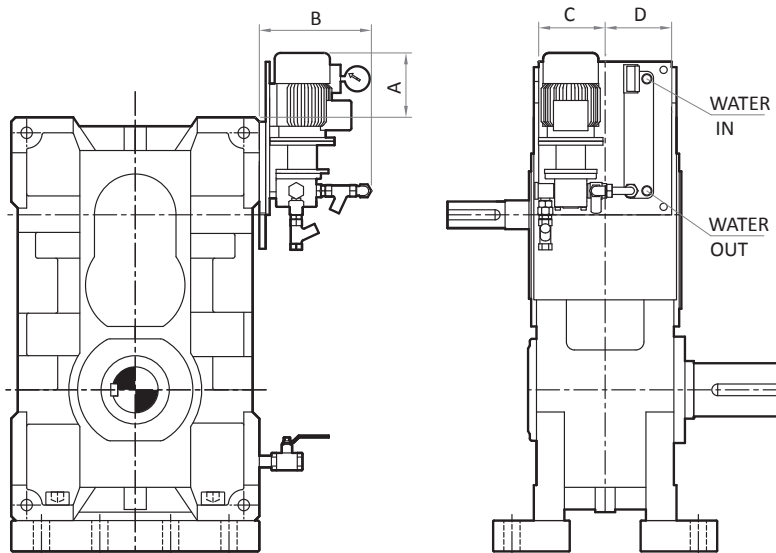

Size	Over driven gear unit			
	Additional cooling system dimensions (with water cooler)			
	A ¹⁾	B ¹⁾	C ¹⁾	D ¹⁾
714 - 715	200	450	200	200
716 - 717	150	450	200	200
718 - 719	100	450	200	200
720 - 721	300	450	225	225
722 - 723	200	450	240	240
724 - 725	150	550	280	280

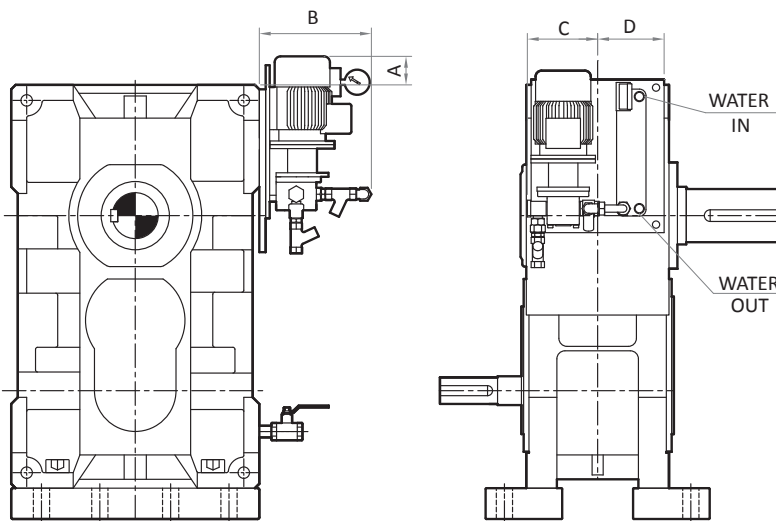

Size	Under driven gear unit			
	Additional cooling system dimensions (with water cooler)			
	A ¹⁾	B ¹⁾	C ¹⁾	D ¹⁾
714 - 715	100	450	200	200
716 - 717	75	450	200	200
718 - 719	50	450	200	200
720 - 721	125	450	225	225
722 - 723	75	450	240	240
724 - 725	50	550	280	280

- Accessories or piping are only for illustration purpose, the actual product may be differ.
- Accessories is shown without piping.

1) Approximate values

8.6 Torque arm details

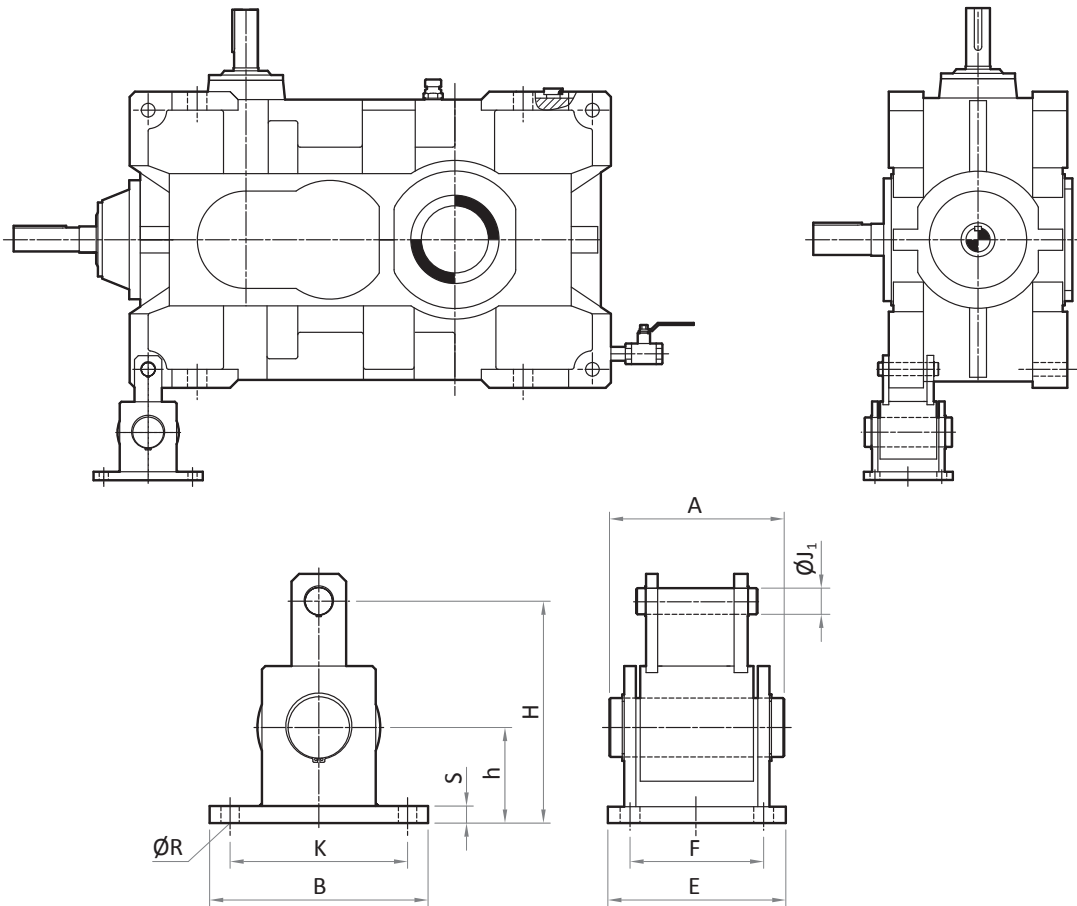

Size	A		B	E	R	H	h	K	F	S	J ₁	Weight (kg)
	Gear unit B2	Gear unit H2/H3/H4/B3/B4/C3/C4										
712 - 713	On Request											
714 - 715	170	170	160	160	18	200	65	120	80	15	25	11
716 - 717	210	195	200	210	18	250	90	160	120	20	25	21
718 - 719	250	225	310	245	18	400	140	260	130	25	30	44
720 - 721	250	225	310	245	18	400	140	260	130	25	35	48
722 - 723	300	300	400	300	23	500	175	320	240	30	40	71
724 - 725	300	300	400	300	23	500	175	320	240	30	50	78

Note:-

- Fan cooling cannot to be used together with Torque arm.
- Because the motor bell housing fixing hole and the torque arm hole are the same for helical gear units, the torque arm will be fixed on the opposite side of the input extension end.
- The torque arm will not be applicable with input double extension for the helical gear unit with motor bell housing.

8.7 Motor mounting adaptor details

8.7.1 Motor mounting flange details (IEC Motors)

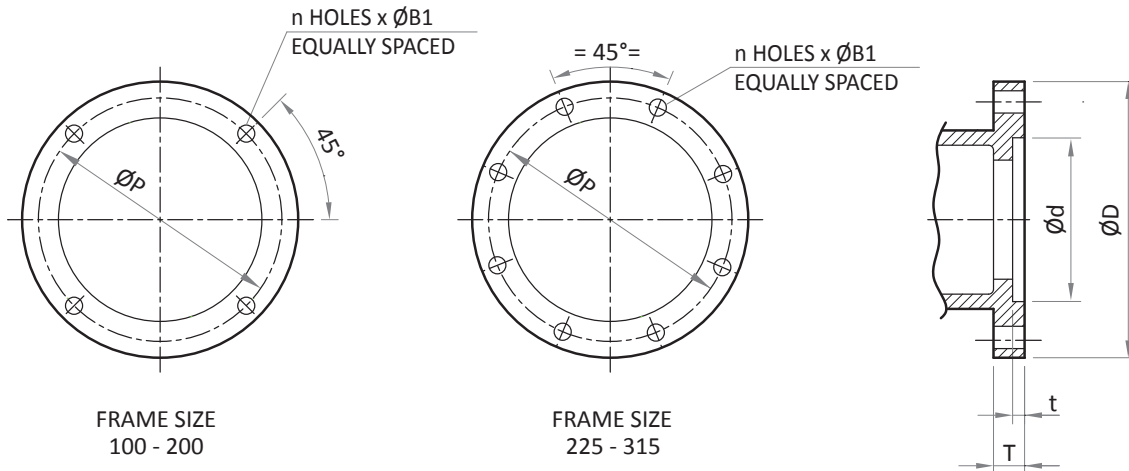

Motor Frame Size	Motor flange dimension detail						
	D	P	d	n	B ₁	t	T
100 L	250	215	180	4	15	6	15
112 M	250	215	180	4	15	6	15
132 S/M	300	265	230	4	15	6	15
160 M/L	350	300	250	4	19	7	20
180 M/L	350	300	250	4	19	7	20
200 L	400	350	300	4	19	7	20
225 S/M	450	400	350	8	19	7	20
250 M	550	500	450	8	19	7	30
280 S/M	550	500	450	8	19	7	30
315 S/M	660	600	550	8	24	9	30

Maximum possible motor frame sizes

Horizontal mounting position						
Gear unit size	H2	H3	H4	B2	B3	B4
714/715	180	180	-	180	180	-
716/717	225	225	180	280	225	180
718/719	280	280	200	315	280	200
720/721	280	280	250	315	280	250
722/723	315	315	280	315	315	280
724/725	315	315	315	315	315	315

Vertical mounting position						
Gear unit size	H2	H3	H4	B2	B3	B4
714/715	225	180	-	180	180	-
716/717	280	250	180	280	225	180
718/719	315	315	200	315	280	200
720/721	315	315	250	315	280	250
722/723	315	315	280	315	315	280
724/725	315	315	315	315	315	315

Note:

- Motor selection based on : 4 pole, 50 Hz.
- ELECON Gear unit with bell housing are designed with ELECON flexible coupling (EFC).
- NEMA motor mounting adaptor On Request

8.7.2 Motor mounting adaptor details for helical gear unit

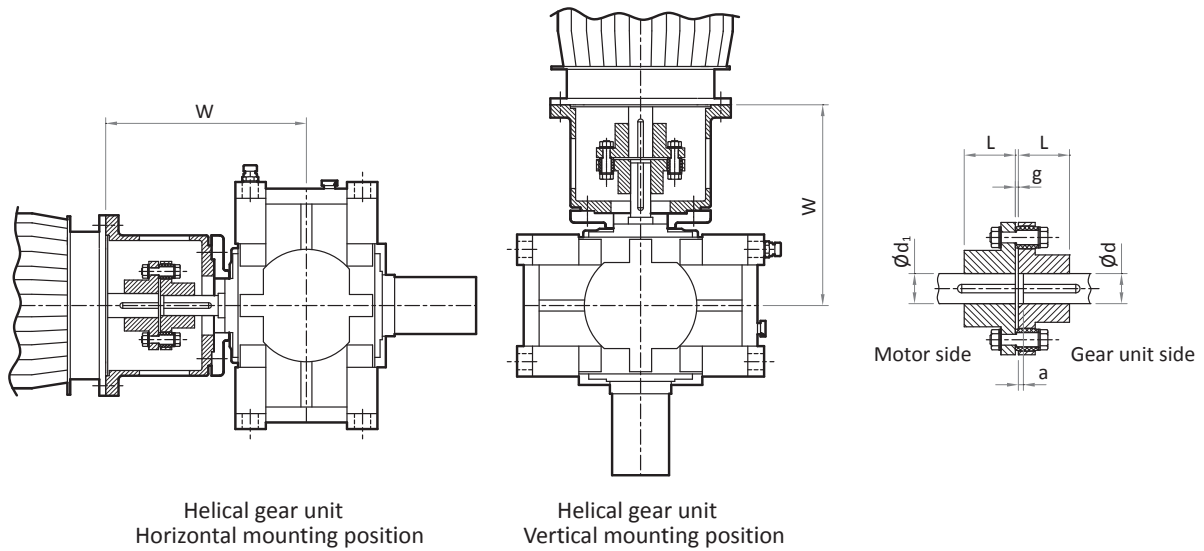

Type : H2														
Size	Motor		Coupling			Gear unit								
	Frame	d ₁	Size	L	g	d	a	w	d	a	w	d	a	w
714-715	132	38	EFC 04	48	3	-	-	-	-	-	-	28	15	353
	160	42	EFC 06	60	3	42	0	383	32	10	383	28	15	383
	180	48	EFC 06	60	3	42	0	383	32	10	383	28	15	383
	200	55	EFC 06	60	3	42	0	383	32	10	383	28	15	383
	225	60	EFC 08	85	5	42	15	430	32	25	430	28	30	430
716-717	180	48	EFC 06	60	3	-	-	-	-	-	-	38	0	418
	200	55	EFC 06	60	3	-	-	-	-	-	-	38	0	418
	225	60	EFC 08	85	5	60	0	490	50	20	490	-	-	-
	250	65	EFC-08	85	5	60	0	490	50	20	490	-	-	-
	280	75	EFC-08	85	5	60	0	490	50	20	490	-	-	-
718-719	225	60	EFC 08	85	5	-	-	-	-	-	-	50	20	490
	250	65	EFC-08	85	5	-	-	-	-	-	-	50	20	490
	280	75	EFC-08	85	5	60	0	490	60	0	490	50	20	490
	315 S/M	80	EFC-11	110	5	60	0	520	60	0	520	50	20	520
720-721	280	75	EFC-11	110	5	-	-	-	-	-	-	60	30	560
	315 S/M	80	EFC-11	110	5	80	0	590	80	0	590	60	30	590
722-723	315 S/M	80	EFC-11	110	5	-	-	-	-	-	-	70	20	630

Applicable only for vertical mounting

8.7.2 Motor mounting adaptor details for helical gear unit

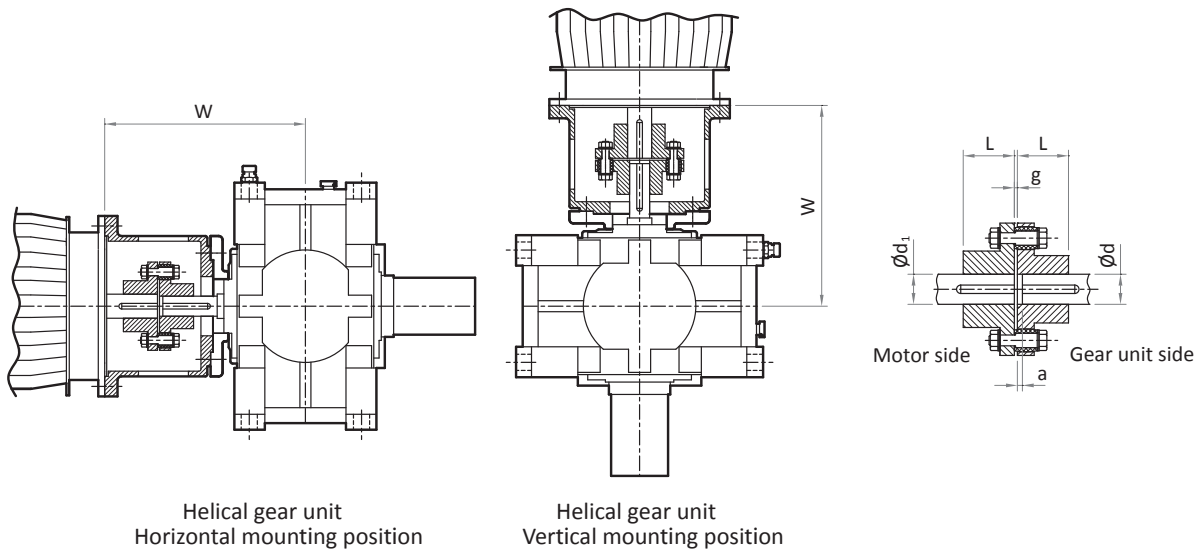

Type : H3											
Size	Motor		Coupling			Gear unit					
	Frame	d ₁	Size	L	g	d	a	w	d	a	w
714-715	100	28	EFC 03	42	3	30	0	318	22	5	318
	112	28	EFC 03	42	3	30	0	318	22	5	318
	132	38	EFC 04	48	3	30	0	338	22	5	338
	160	42	EFC 06	60	3	30	0	368	22	5	368
	180	48	EFC 06	60	3	30	0	368	-	-	-
716-717	132	38	EFC 04	48	3	-	-	-	32	10	393
	160	42	EFC 06	60	3	42	0	423	32	10	423
	180	48	EFC 06	60	3	42	0	423	32	10	423
	200	55	EFC 06	60	3	42	0	423	-	-	-
	225	60	EFC 08	85	5	42	0	455	-	-	-
	250	65	EFC 08	85	5	42	0	455	-	-	-
718-719	160	42	EFC 06	60	3	42	0	423	32	10	423
	180	48	EFC 06	60	3	42	0	423	32	10	423
	200	55	EFC 06	60	3	42	0	423	32	10	423
	225	60	EFC 08	85	5	42	15	470	32	25	470
	250	65	EFC 08	85	5	42	15	470	-	-	-
	280	75	EFC-08	85	5	42	15	470	-	-	-
	315 S	80	EFC-11	110	5	42	15	500	-	-	-
720-721	200	55	EFC 06	60	3	60	0	523	-	-	-
	225	60	EFC 08	85	5	60	0	555	42	30	555
	250	65	EFC 08	85	5	60	0	555	42	30	555
	280	75	EFC-08	85	5	60	0	555	-	-	-
	315 S/M	80	EFC-11	110	5	60	0	585	-	-	-
722-723	225	60	EFC-11	110	5	-	-	-	45	40	585
	250	65	EFC-11	110	5	70	0	585	45	40	585
	280	75	EFC-11	110	5	70	0	585	45	40	585
	315 S/M	80	EFC-11	110	5	70	0	615	45	40	615
724-725	225	60	EFC-11	110	5	-	-	-	60	30	645
	250	65	EFC-11	110	5	-	-	-	60	30	645
	280	75	EFC-11	110	5	85	0	645	60	30	645
	315 S/M	80	EFC-11	110	5	85	0	675	60	30	675

 Applicable only for Vertical Mounting

8.7.2 Motor mounting adaptor details for helical gear unit

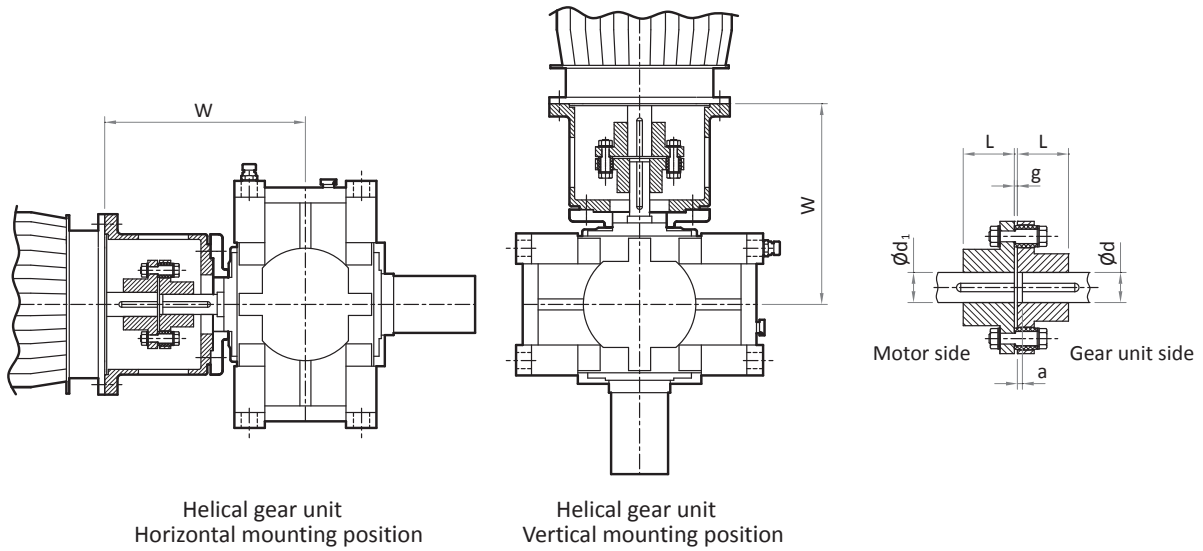

Type : H4														
Size	Motor		Coupling			Gear unit								
	Frame	d ₁	Size	L	g	d	a	w	d	a	w	d	a	w
716-717	100	28	EFC 03	42	3	22	12	313	22	12	313	18	12	313
	112	28	EFC 03	42	3	22	12	313	22	12	313	18	12	313
	132	38	EFC 04	48	3	22	12	333	22	12	333	-	-	-
	160	42	EFC 06	60	3	22	12	363	-	-	-	-	-	-
	180	48	EFC 06	60	3	22	12	363	-	-	-	-	-	-
718-719	100	28	EFC 03	42	3	-	-	-	28	0	338	22	5	338
	112	28	EFC 03	42	3	-	-	-	28	0	338	22	5	338
	132	38	EFC 04	48	3	30	0	358	28	0	358	22	5	358
	160	42	EFC 06	60	3	30	0	388	28	0	388	-	-	-
	180	48	EFC 06	60	3	30	0	388	-	-	-	-	-	-
	200	55	EFC 06	60	3	30	0	388	-	-	-	-	-	-
720-721	132	38	EFC 04	48	3	42	0	428	32	10	428	28	15	428
	160	42	EFC 06	60	3	42	0	458	32	10	458	28	15	458
	180	48	EFC 06	60	3	42	0	458	32	10	458	-	-	-
	200	55	EFC 06	60	3	42	0	458	-	-	-	-	-	-
	225	60	EFC 08	85	5	42	30	520	-	-	-	-	-	-
	250	65	EFC 08	85	5	42	30	520	-	-	-	-	-	-
722-723	132	38	EFC 04	48	3	-	-	-	32	10	438	28	15	438
	160	42	EFC 06	60	3	42	0	468	32	10	468	28	15	468
	180	48	EFC 06	60	3	42	0	468	32	10	468	28	15	468
	200	55	EFC 06	60	3	42	0	468	32	10	468	-	-	-
	225	60	EFC 08	85	5	42	30	530	-	-	-	-	-	-
	250	65	EFC 08	85	5	42	30	530	-	-	-	-	-	-
	280	75	EFC-08	85	5	42	30	530	-	-	-	-	-	-
724-725	160	42	EFC 06	60	3	-	-	-	45	20	578	-	-	-
	180	48	EFC 06	60	3	60	0	578	45	20	578	-	-	-
	200	55	EFC 06	60	3	60	0	578	45	20	578	-	-	-
	225	60	EFC 08	85	5	60	0	610	45	20	610	-	-	-
	250	65	EFC 08	85	5	60	0	610	45	20	610	-	-	-
	280	75	EFC-08	85	5	60	0	610	-	-	-	-	-	-
	315 S/M	80	EFC-11	110	5	60	0	640	-	-	-	-	-	-

8.7.3 Motor mounting adaptor details for bevel - helical gear unit

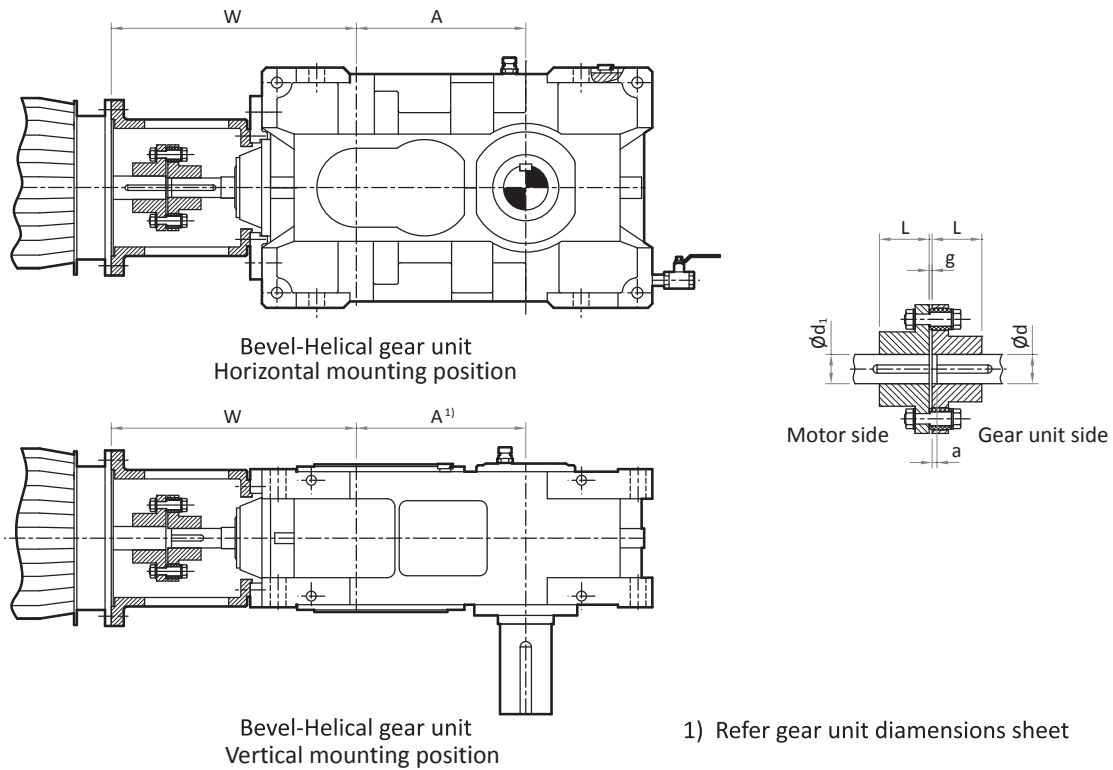

Type : B2											
Size	Motor		Coupling			Gear unit					
	Frame	d ₁	Size	L	g	d	a	w	d	a	w
714	132	38	EFC 04	48	3	35	0	443	32	0	443
	160	42	EFC 06	60	3	35	0	473	32	0	473
	180	48	EFC 06	60	3	35	0	473	32	0	473
715	160	42	EFC 06	60	3	45	0	548	35	20	548
	180	48	EFC 06	60	3	45	0	548	35	20	548
716-717	160	42	EFC 06	60	3	-	-	-	45	10	583
	180	48	EFC 06	60	3	55	0	583	45	10	583
	200	55	EFC 06	60	3	55	0	583	45	10	583
	225	60	EFC 08	85	5	55	0	615	45	10	615
	250	65	EFC 08	85	5	55	0	615	45	10	615
718-719	280	75	EFC-08	85	5	55	0	615	45	10	615
	225	60	EFC 08	85	5	70	0	720	55	30	720
	250	65	EFC 08	85	5	70	0	720	55	30	720
	315 S/M	80	EFC-11	110	5	70	0	750	55	30	750
720-721	250	65	EFC 08	85	5	-	-	-	60	30	795
	280	75	EFC-11	110	5	80	0	795	60	30	795
	315 S/M	80	EFC-11	110	5	80	0	825	60	30	825
722-723	280	75	EFC-08	85	5	-	-	-	70	20	920
	315 S/M	80	EFC-11	110	5	90	0	950	70	20	950
724-725	315 M	80	EFC-11	110	5	-	-	-	80	30	1065

8.7.3 Motor mounting adaptor details for bevel - helical gear unit

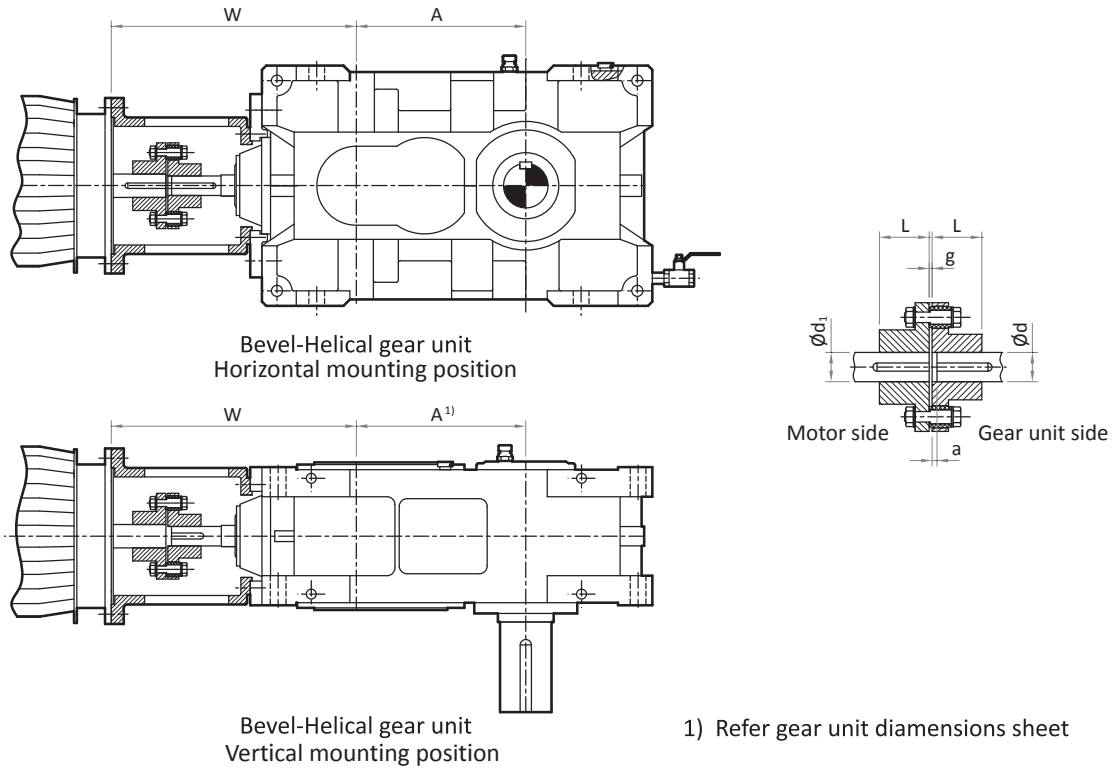

Type : B3											
Size	Motor		Coupling			Gear Unit					
	Frame	d ₁	Size	L	g	d	a	w	d	a	w
714-715	100	28	EFC 03	42	3	30	0	383	-	-	-
	112	28	EFC 03	42	3	30	0	383	-	-	-
	132	38	EFC 04	48	3	30	0	403	-	-	-
	160	42	EFC 06	60	3	30	0	433	-	-	-
	180	48	EFC 06	60	3	30	0	433	-	-	-
716-717	132	38	EFC 04	48	3	-	-	-	32	0	443
	160	42	EFC 06	60	3	35	0	473	32	0	473
	180	48	EFC 06	60	3	35	0	473	32	0	473
	200	55	EFC 06	60	3	35	0	473	-	-	-
	225	60	EFC 08	85	5	35	0	505	-	-	-
718-719	160	42	EFC 06	60	3	45	0	548	35	20	548
	180	48	EFC 06	60	3	45	0	548	35	20	548
	200	55	EFC 06	60	3	45	0	548	35	20	548
	225	60	EFC 08	85	5	45	0	580	35	20	580
	250	65	EFC 08	85	5	45	0	580	-	-	-
	280	75	EFC-08	85	5	45	0	580	-	-	-
720-721	180	48	EFC 06	60	3	55	0	583	45	10	583
	200	55	EFC 06	60	3	55	0	583	45	10	583
	225	60	EFC 08	85	5	55	0	615	45	10	615
	250	65	EFC 08	85	5	55	0	615	45	10	615
	280	75	EFC-08	85	5	55	0	615	45	10	615
722-723	225	60	EFC 08	85	5	70	0	720	55	30	720
	250	65	EFC 08	85	5	70	0	720	55	30	720
	280	75	EFC-08	85	5	70	0	720	-	-	-
	315 S/M	80	EFC-11	110	5	70	0	750	55	30	750
724-725	225	60	EFC 08	85	5	-	-	-	60	30	795
	250	65	EFC 08	85	5	-	-	-	60	30	795
	280	75	EFC-08	85	5	80	0	795	-	-	-
	315 S/M	80	EFC-11	110	5	80	0	825	60	30	825

8.7.3 Motor mounting adaptor details for bevel - helical gear unit

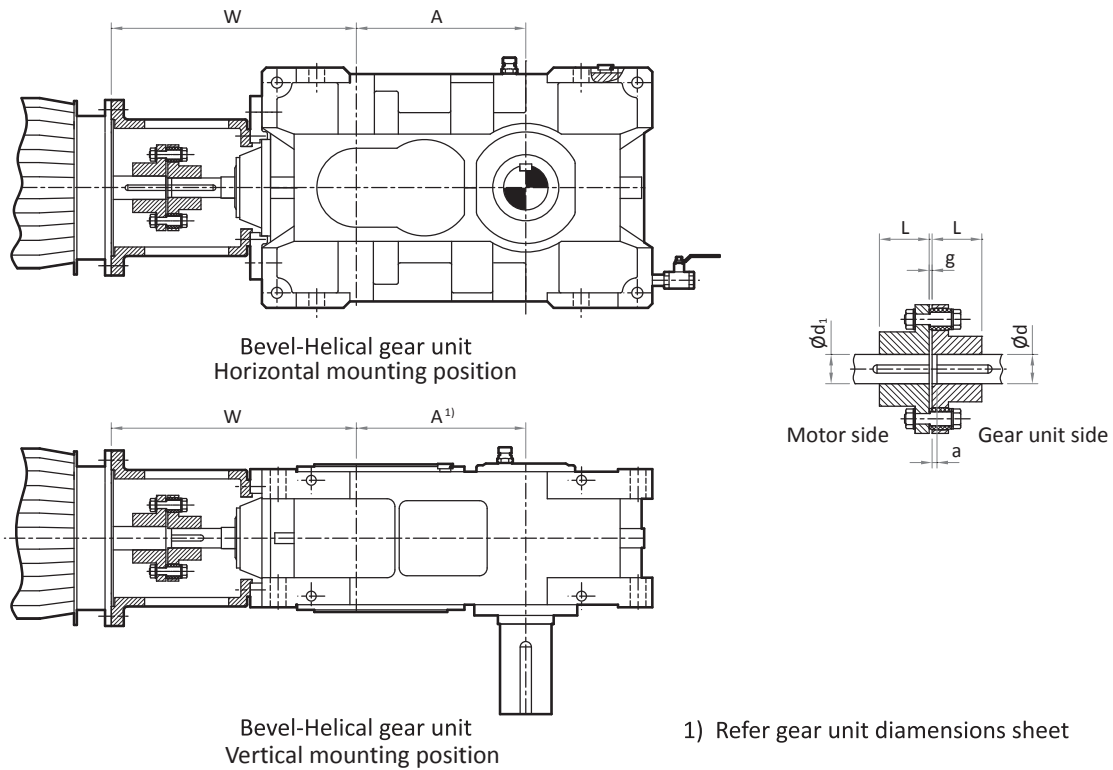

Type : B4														
Size	Motor		Coupling			Gear unit								
	Frame	d ₁	Size	L	g	d	a	w	d	a	w	d	a	w
716-717	100	28	EFC 03	42	3	28	0	363	20	5	363	20	5	363
	112	28	EFC 03	42	3	28	0	363	20	5	363	20	5	363
	132	38	EFC 04	48	3	28	0	383	20	5	383	-	-	-
	160	42	EFC 06	60	3	28	0	413	-	-	-	-	-	-
	180	48	EFC 06	60	3	28	0	413	-	-	-	-	-	-
718-719	100	28	EFC 03	42	3	-	-	-	30	0	383	22	5	383
	112	28	EFC 03	42	3	-	-	-	30	0	383	22	5	383
	132	38	EFC 04	48	3	30	0	403	30	0	403	22	5	403
	160	42	EFC 06	60	3	30	0	433	30	0	433	-	-	-
	180	48	EFC 06	60	3	30	0	433	-	-	-	-	-	-
	200	55	EFC 06	60	3	30	0	433	-	-	-	-	-	-
720-721	132	38	EFC 04	48	3	35	0	443	32	0	443	32	0	443
	160	42	EFC 06	60	3	35	0	473	32	0	473	32	0	473
	180	48	EFC 06	60	3	35	0	473	32	0	473	-	-	-
	200	55	EFC 06	60	3	35	0	473	-	-	-	-	-	-
	225	60	EFC 08	85	5	35	15	520	-	-	-	-	-	-
	250	65	EFC 08	85	5	35	15	520	-	-	-	-	-	-
722-723	132	38	EFC 04	48	3	-	-	-	-	-	-	35	20	518
	160	42	EFC 06	60	3	45	0	548	35	20	548	35	20	548
	180	48	EFC 06	60	3	45	0	548	35	20	548	35	20	548
	200	55	EFC 06	60	3	45	0	548	35	20	548	-	-	-
	225	60	EFC 08	85	5	45	0	580	35	20	580	-	-	-
	250	65	EFC 08	85	5	45	0	580	-	-	-	-	-	-
	280	75	EFC-08	85	5	45	0	580	-	-	-	-	-	-
724-725	160	42	EFC 06	60	3	-	-	-	45	10	583	35	30	583
	180	48	EFC 06	60	3	55	0	583	45	10	583	-	-	-
	200	55	EFC 06	60	3	55	0	583	45	10	583	-	-	-
	225	60	EFC 08	85	5	55	0	615	45	10	615	-	-	-
	250	65	EFC 08	85	5	55	0	615	-	-	-	-	-	-
	280	75	EFC-08	85	5	55	0	615	-	-	-	-	-	-
	315 S/M	80	EFC-11	110	5	55	0	645	-	-	-	-	-	-

8.8 Mounting flange (Output shaft side)

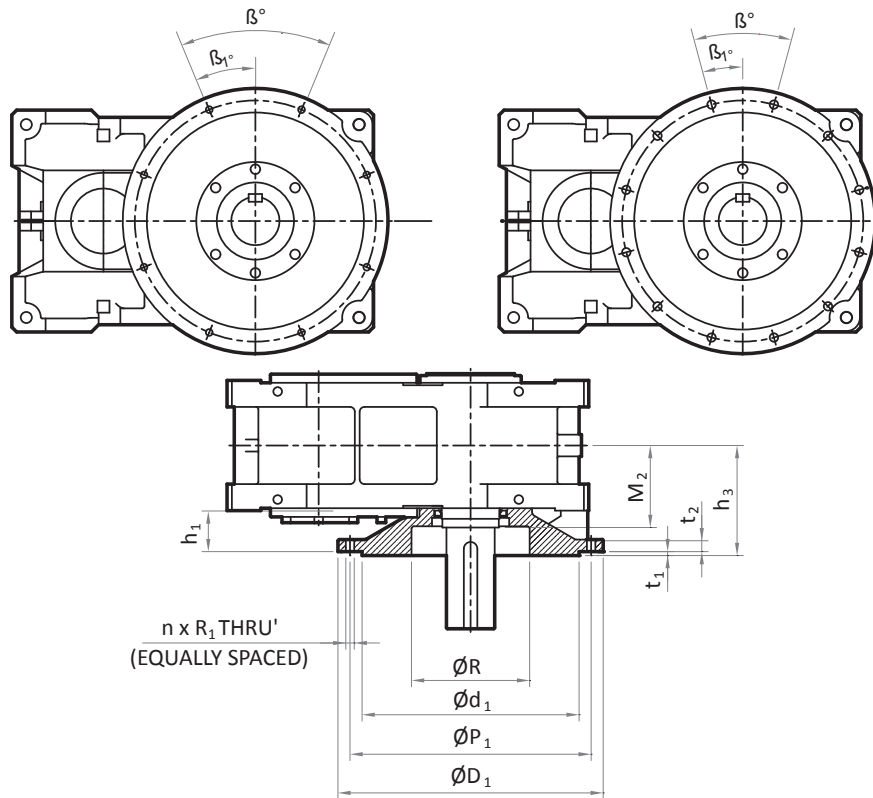

Type : H2/H3/H4/B3/B4													
Size	D ₁	d ₁	P ₁	t ₂	t ₁	h ₁	M ₂	h ₃	R _{max}	n	R ₁	β	β ₁
714	450	350	400	25	5	75	150	200	205	8	18	45	22.5
715	450	350	400	25	5	75	150	200	205	8	18	45	
716	550	450	500	25	5	90	170	225	245	8	18	45	
717	550	450	500	25	5	90	170	225	245	8	18	45	0
718	660	550	600	25	5	134	200	295	290	8	22	45	
719	660	550	600	25	5	134	200	295	315	8	22	45	
720	660	550	600	25	6	135	240	335	325	12	22	30	
721	660	550	600	35	6	135	240	335	355	12	26	30	
722	800	680	740	40	6	129	270	366	420	12	26	30	
723	800	680	740	40	6	129	270	366	435	12	26	30	
724	840	650	760	50	6	102	335	382	450	12	M30	30	
725	840	650	760	50	6	102	335	382	480	12	M30	30	

Type : B2													
Size	D ₁	d ₁	P ₁	t ₂	t ₁	h ₁	M ₂	h ₃	R _{max}	n	R ₁	β	β ₁
714	450	350	400	25	5	80	195	230	205	8	18	45	22.5
715	450	350	400	25	5	80	210	230	205	8	18	45	
716	550	450	500	25	5	90	220	263	245	8	18	45	
717	550	450	500	25	5	90	220	263	245	8	18	45	0
718	660	550	600	30	5	134	255	345	290	8	22	45	
719	660	550	600	30	5	134	255	345	315	8	22	45	
720	660	550	600	30	6	134	290	380	325	12	22	30	
721	660	550	600	35	6	134	290	380	355	12	26	30	
722	800	680	740	40	6	110	345	420	420	12	26	30	
723	800	680	740	40	6	110	345	420	435	12	26	30	
724	840	650	760	50	6	102	390	432	450	12	M30	30	
725	840	650	760	50	6	102	390	432	480	12	M30	30	

8.9 Shaft center details

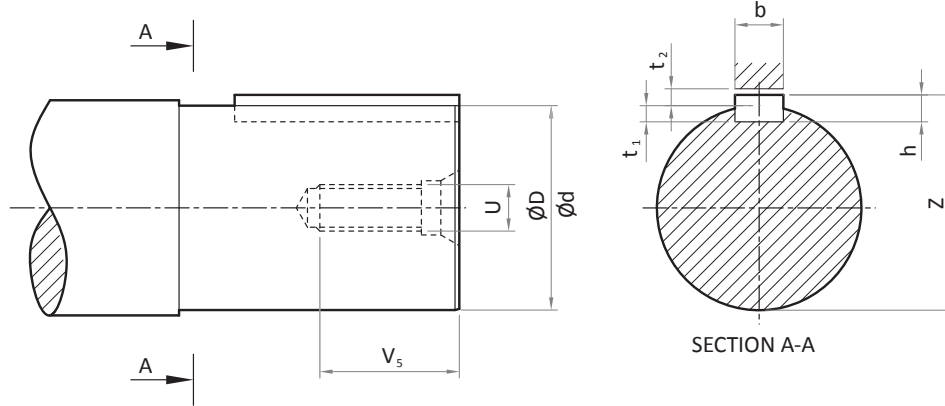

Shaft dia, d/D		Width b	Height h	Keyway depth in shaft t ₁	Tolerance	Keyway depth in hub t ₂	Tolerance
Over	Up to						
17	22	6	6	3.5	+0.1	2.8	+0.1
22	30	8	7	4	+0.2	3.3	+0.2
30	38	10	8	5		3.3	
38	44	12	8	5		3.3	
44	50	14	9	5.5		3.8	
50	58	16	10	6		4.3	
58	65	18	11	7		4.4	
65	75	20	12	7.5		4.9	
75	85	22	14	9		5.4	
85	95	25	14	9		5.4	
95	110	28	16	10		6.4	
110	130	32	18	11	7.4	+0.3	+0.3
130	150	36	20	12	8.4		
150	170	40	22	13	9.4		
170	200	45	25	15	10.4		
200	230	50	28	17	11.4		

Shaft dia, d/D		U	V _s
Over	Up to		
16	21	M6	16
21	24	M8	19
24	30	M10	22
30	38	M12	28
38	50	M16	36
50	85	M20	42
85	130	M24	50
130	225	M30	60

Extension diameter		Tolerance zone	
Over	Included		
18	30	k6	+0.015 +0.002
30	50	k6	+0.018 +0.002
50	80	k6	+0.018 +0.002
80	100	k6	+0.025 +0.003
100	120	m6	+0.035 +0.013
120	180	m6	+0.040 +0.015
180	200	m6	+0.046 +0.017
200	250	n6	+0.060 +0.031

B		Tolerance zone	
Over	Included		
3	6	h9	0.000 -0.030
8	10		0.000 -0.036
12	18		0.000 -0.043
20	28		0.000 -0.052
32	50		0.000 -0.062

NOTE:-

- Parallel key acc. to DIN 6885/1 form B and parallel keyway acc. to DIN 6885/1
- The tolerance zone for the hub keyway width b is JS9.
- Shaft Centering according to DIN 332, shape DS (with thread)

radicon 

with you at every turn

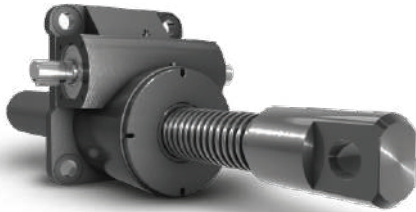

BD Screw Jack

benzlers 

with you at every turn

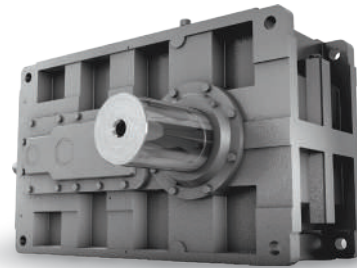

**Benzlers - Series G
Industrial Reducer**



**Series J
For excellence - For safety**

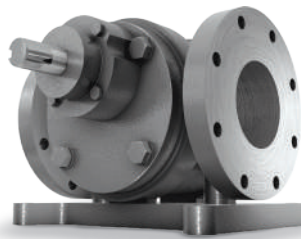

Rolid Gear Pump



Series AM Worm Gear

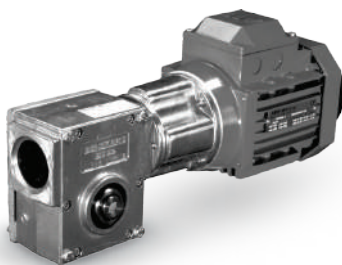

**Series Bs
Worm Gear**



**Series AJ
Worm Gear**

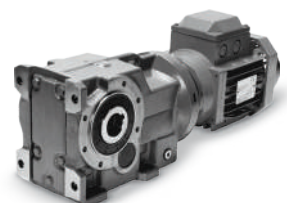
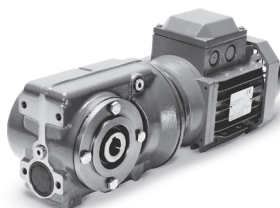
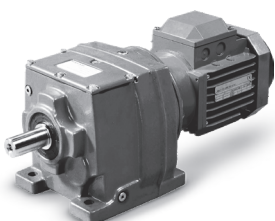

Series M, C, F and K Geared Motors For availability - For performance



**Eleloc SD - Series
(Shrink Disc)**



Electro Hydraulic Thrustor

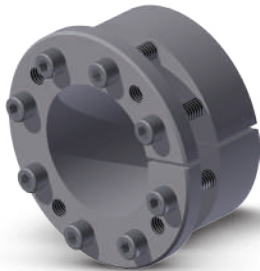

**Eleloc LA - Series
(Locking Assemblies)**

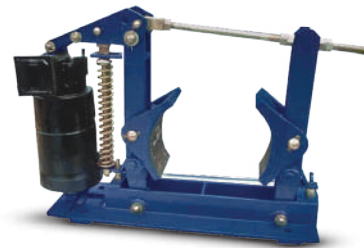

**Electro Hydraulic
Thrustor Brake**



**Cam Clutch - Hold Back
(EPL BR-HT Series)**

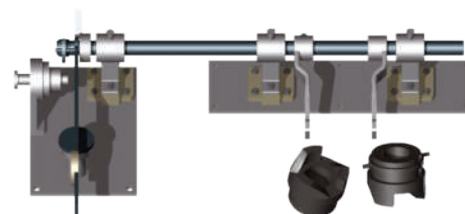

**Over Riding
Spiral Jaw Clutch Coupling**



Centrifugal Brake



Hydraulic Power Unit for Side Arm Charger



Force Lubrication System Integrator



Cylinders



Power Unit



Series M

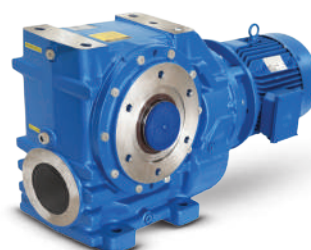

Series C



Series F

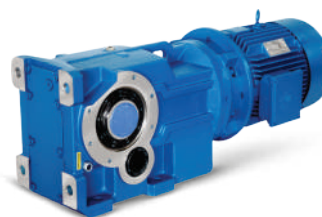

Series K



Series A

NOTES

A series of horizontal dotted lines for writing notes.

DOMESTIC NETWORK



 MANUFACTURING FACILITIES

 SALES OFFICE

Domestic Branches :

AHMEDABAD

Tel: +91-79-26406683
Email: infogear@elecon.com

ASANSOL

Tel: +91-2692-238 702 / 238 701 / 236 469
Email: infogear@elecon.com

BANGALORE

Tel: +91-80-25250219//25251834
Email: infogear@elecon.com

BILASPUR

Tel: +91-2692-238 702 / 238 701 / 236 469
Email: infogear@elecon.com

CHENNAI

Tel: +91-44-24349237/24349521
Email: infogear@elecon.com

DHANBAD

Tel: +91-2692-238 702 / 238 701 / 236 469
Email: infogear@elecon.com

HYDRABAD

Tel: +91-2692-238 702 / 238 701 / 236 469
Email: infogear@elecon.com

KOLKATA

Tel: +91-33-2476 1861
Email: infogear@elecon.com

MUMBAI

Tel: +91-2692-238 702 / 238 701 / 236 469
Email: infogear@elecon.com

NAGPUR

Tel: +91-2692-238 702 / 238 701 / 236 469
Email: infogear@elecon.com

NEW DELHI

Tel: +91-2692-238 702 / 238 701 / 236 469
Email: infogear@elecon.com

PUNE

Tel: +91-2692-238 702 / 238 701 / 236 469
Email: infogear@elecon.com

RAIPUR

Tel: +91-2692-238 702 / 238 701 / 236 469
Email: infogear@elecon.com

SECUNDERABAD

Tel: +91-40-2784 6984/2784 5250
Email: infogear@elecon.com

VADODARA

Tel: 91-2692- 2692-238 702 / 238 701 / 236 469
Email: infogear@elecon.com

Service Center:

ELECON ENGG. CO. LTD.

Refurbishment Center - Gear
Anand-Sojitra Road,
Vallabh Vidyanagar - 388 120 (Guj.)
Tel.: +91 2692 227544
Email: bkgajjar@elecon.com

ELECON ENGG. CO. LTD.

S.F.No.44/3, Madurai Road,
T Kunnathur Village, Peraiyur Taluk,
Madurai, Tamilnadu - 625708
Mo.: +91 99406 37009
Email: pramchandran@elecon.com

GLOBAL PRESENCE



MANUFACTURING FACILITIES
 ASSEMBLY & REPAIR CENTER
 SALES OFFICE
 SALES REPRESENTATIVE

INDIA

Manufactured by:
Elecon Engineering Co. Ltd.
 Anand-Sojitra Road, Vallabh Vidyanagar -
 388120, Gujarat, India.
 Ph.: +91-2692-238 702 / 238 701 / 236 469
 Email: info@elecon.com
 Web: www.elecon.com
 CIN L29100GJ1960PLC001082

SOUTH EAST ASIA REGION

Elecon Singapore Pte. Ltd.
 10 Anson Road, #10-11 International Plaza,
 Singapore 079903
 Ph.: +65-68759262
 Email: salesap@elecon.com
 Web: www.elecon.com

Radicon Transmission (Thailand) Ltd.

700/43 Moo 6 Amata City Chonburi
 Industrial Estate, Tumbol Klong Tum Ru,
 Muang Chonburi 20000 Thailand
 Ph: +66 38 459 044 ext. 226
 Email: salesap@radicon.com
 Web: www.radicon.com

MIDDLE EAST & AFRICA REGION

Elecon Middle East FZCO
 Dubai Airport Free Zone,
 POBox - 54754, Dubai, UAE
 Ph.: +971 4 6091 424/5 , +971-50-2755487,
 +971-4-6091-426
 Email: rajen@elecon.com
 Web: www.elecon.com

NORTH & SOUTH AMERICA REGION

Radicon Drive Systems Inc
 2475 Alft Lane
 Elgin, IL 60124 USA
 Ph.: +1 (888) MY-GEARS / +1 888 69-4327,
 +1 (847) 593-9950
 Email: info.us@radicon.com
 Web: us.radicon.com

EUROPE REGION

Radicon Transmission UK
 Unit J3, Lowfields Business Park
 Lowfields Way Elland,
 West Yorkshire HX5 9DA, United Kingdom
 Ph.: + 44 1484 465 800, + 44 1484 465 801
 Email: sales@radicon.com
 Web: www.radicon.com

Benzlers AB

Singelvägen 12
 702 36 Örebro Sweden
 Ph.: +46 (0) 42 18 68 00
 Email: order@benzlers.com
 Web: www.benzlers.se/en

Benzler Antriebstechnik GmbH

Erna-Scheffler-Str. 2
 40476 Düsseldorf , Germany
 Tel: +800 3504000
 Email: mail@benzlers.com
 Web: www.benzlers.de

Benzler-TBA BV

Jachthavenweg 2
 5928 NT Venlo ,
 The Netherlands
 Tel: + 31 77 324 59 00
 Email: mail@benzlers.com
 Web: www.benzlers.nl