

# radicon



with you at every turn

# benzlers



with you at every turn

Benzlers Screw Jacks



Benzlers Screw Jacks  
CBD-2.00GB0613

# PRODUCTS IN THE RANGE

Serving an entire spectrum of mechanical drive applications from food, energy, mining and metal; to automotive, aerospace and marine propulsion, we are here to make a positive difference to the supply of drive solutions.

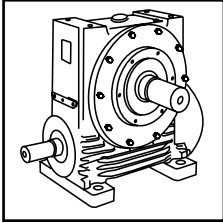

**Series A**  
Worm Gear units and geared motors in single & double reduction types

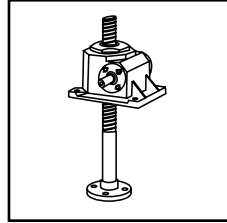

**Series BD**  
Screwjack worm gear unit

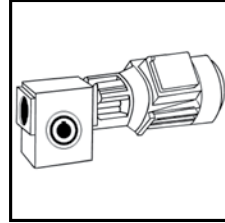

**Series BS**  
Worm gear unit

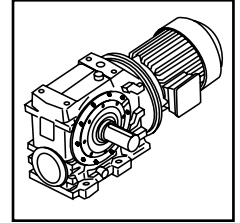

**Series C**  
Right angle drive helical worm geared motors & reducers

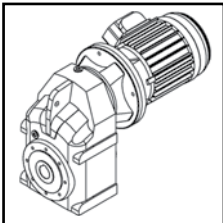

**Series F**  
Parallel shaft helical geared motors & reducers

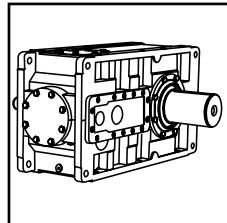

**Series G**  
Helical parallel shaft & bevel helical right angle drive gear units

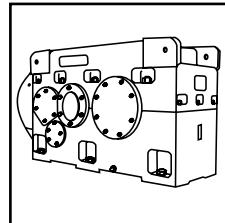

**Series H**  
Large helical parallel shaft & bevel helical right angle drive units

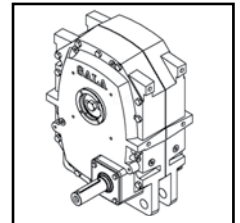

**Series J**  
Shaft mounted helical speed reducers

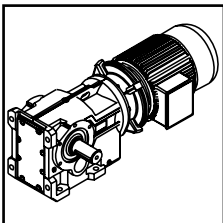

**Series K**  
Right angle helical bevel helical geared motors & reducers

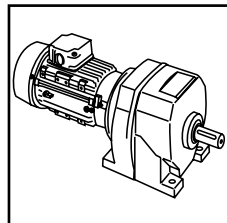

**Series M**  
In-line helical geared motors & reducers

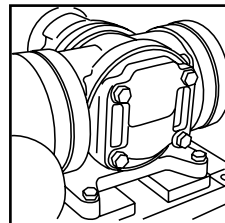

**Roloid Gear Pump**  
Lubrication and fluid transportation pump

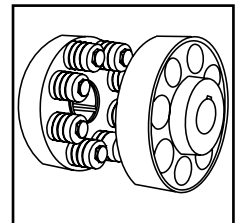

**Series X Cone Ring**  
Pin and bush elastomer coupling

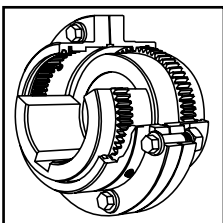

**Series X Gear**  
Torsionally rigid, high torque coupling

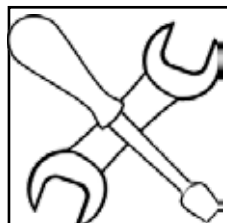

**Service & Repair**  
All brands and types

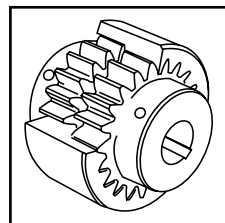

**Series X Nylon**  
Gear coupling with nylon sleeve

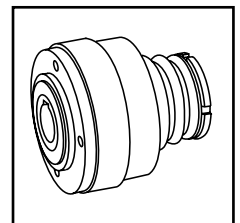

**Series X Torque Limiter**  
Overload protection device



We offer a wide range of repair services and many years experience of repairing demanding and highly critical transmissions in numerous industries.

We can create custom engineered transmission solutions of any size and configuration.

# ATEX

## Compliance Assured



Total compliance with the ATEX Directive safeguarding the use of industrial equipment in potentially explosive atmospheres is assured for users of our geared products.

Certification is available for standard gearboxes and geared motors with badging displaying the ATEX zone, name and location of the manufacturer, designation of series or type, serial number, year of manufacture, Ex symbol and equipment group/category.

ATEX directive 94/9/EC (also known as ATEX 95 or ATEX 100A) enforced in all EC member states. Compliance is compulsory for designers, manufacturers or suppliers of electrical and non-electrical equipment for use in potentially explosive atmospheres created by the presence of flammable gases, vapours, mists or dusts.

Ex compliant standard gearboxes can be supplied against Groups 2 or 3 for surface industries in designated hazardous location Zones 1 and 2 for gases, vapours and mists; and in Zones 21 and 22 for dusts.



# SERIES BD

## CONTENTS PAGE

Introduction _____	2
Standard and variant executions _____	3
Selection guide _____	5
Product codification _____	8
Determination of type _____	9
Selection of jacks _____	10
Technical data: BD - BDL _____	13
Power ratings BD - BDL _____	18
Dimensions BD - BDL _____	30
Options _____	34
Technical data: BDK - BDKL _____	43
Power ratings BDK - BDKL _____	45
Dimensions BDK - BDKL _____	49
IEC motorflange _____	53
Trunnion _____	54
Example of arrangements _____	55
Universal joint shaft _____	56
Bevel gears _____	57
Telescopic spring protection _____	60
Lubrication of screw jacks _____	61

We are a company in the transmission field with comprehensive experience in manufacturing and marketing MECHANICAL WORM GEAR SCREW JACKS, and complete screw jack systems.

With this catalogue we have made it easy to select a screw jack or screw jack system suitable for your application. You can also consult our Technical Sales and Engineering department. They will help you with computer calculations and suggestions, for both standard and special applications.

With our global subsidiaries and good sales network, we are able to give the optimum solution on a local basis.

Please refer to the back page of this publication for details of the company operating on your market.

### **BD and BDL**

Mechanical worm gear screw jack with trapezoidal lifting screw available with translating lifting screw or lifting nut.

8 standard sizes.

Capacities up to 1000 kN (100 tonne)

1500 kN (150 tonne) on request.

Lifting speed up to 2.4 m/min (40 mm/s).

Double speed with two-start lifting screw.

Standard lifting screw length up to 6 m.

Longer on request.

Self-locking for standard single start lifting screw in the majority of non vibrating operating conditions  
Consult your local sales representative for further details.

Small side loads accepted only on type BD, consult your local sales representative for detailed information.

### **BDK and BDKL**

Mechanical worm gear ball screw jack, available with translating lifting screw or lifting nut.

Capacities up to 125 kN (12.5 tonne).

200 kN (20 tonne) with ball screw available on request.

500 kN (50 tonne) with roller screw available on request.

Lifting speeds up to 5.4 m/min (90 mm/s)

Faster on request.

Standard lifting screw length up to 5.5 m.

Not self-locking, must be combined with a brake arrangement.

### **Special screw jack BSD and BSDL 40-71**

BS-Worm gears size 40 to 71 can be combined with trapezoidal lifting screw or ball screw with translating screw or lifting nut.

Capacities up to 30 kN (3 tonne)

# SERIES BD

## STANDARD & VARIANT EXECUTIONS

### Standard Executions

**BD** Screw jack with Translating Lifting Screw

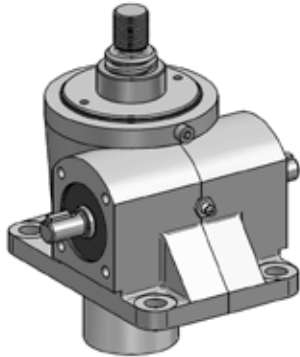

Fig. 1

**BDL** Screw jack with Lifting nut

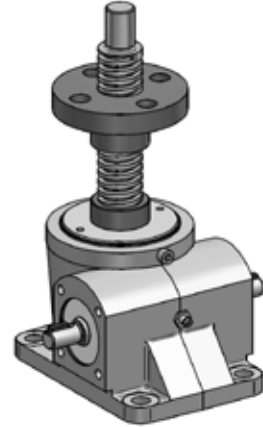

Fig. 2

Screw jack with PVC **Bellows**

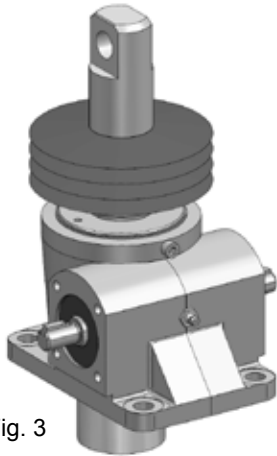

Fig. 3

Screw jack with **Motor Flange**

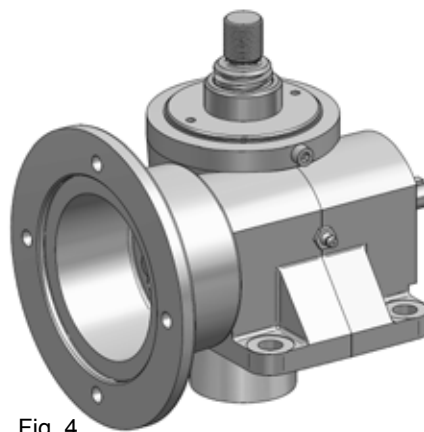

Fig. 4

Screw jack with Stop nut **SM**

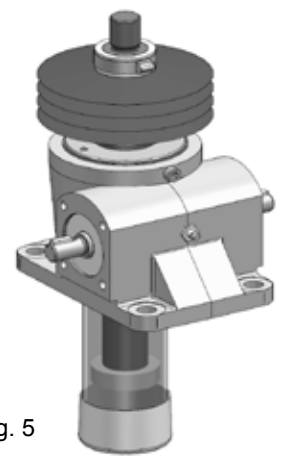

Fig. 5

**BDK** Ball Screw jack with Translating Lifting Screw

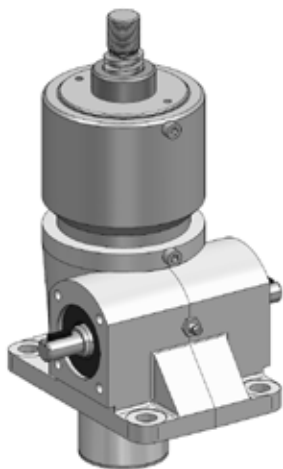

Fig. 6

**BDKL** Ball Screw jack with Lifting nut

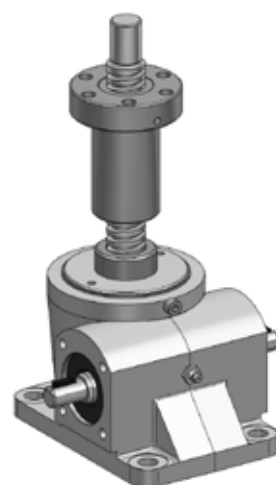

Fig. 7

# SERIES BD

## VARIANT & SPECIAL EXECUTIONS

### Variant Executions

**LR Locked against rotation**

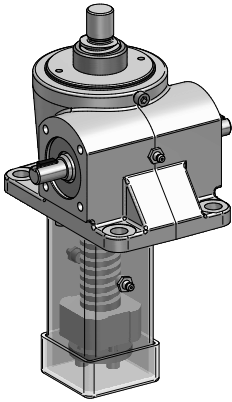

Fig. 8

**LRK Locked against rotation with key**

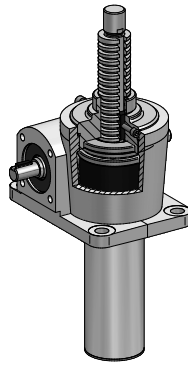

Fig. 9

**ABL Antibacklash**

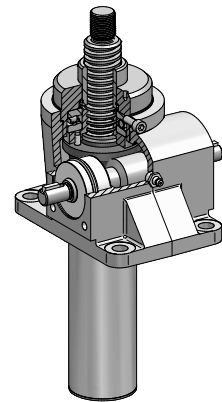

Fig. 10

**LS Limit switches- Tele mecanique**

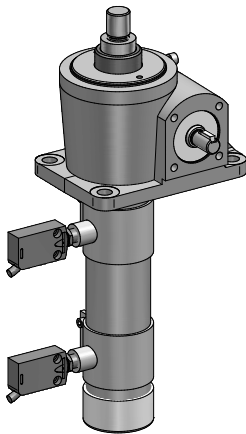

Fig. 11

**MLS Magnetic Limit switches**

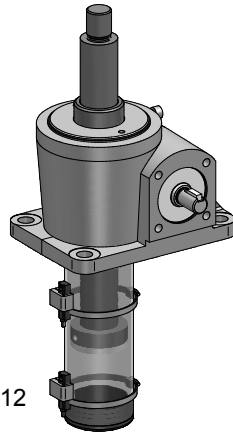

Fig. 12

**SHM Safety nut**

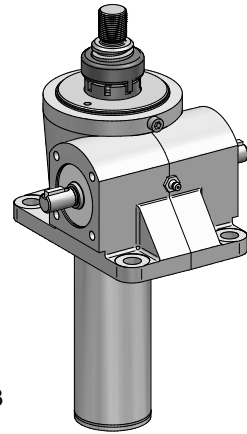

Fig. 13

**Screwjack with Reinforced Projection Tube**

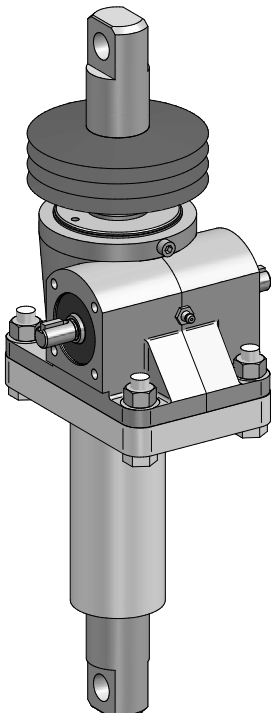

Fig. 14

**Screw jack with Worm gear motor**

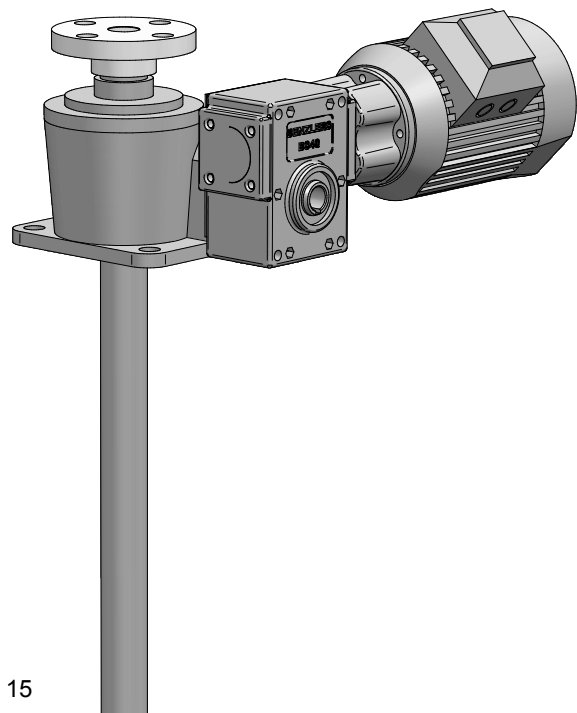

Fig. 15



SF number:

KAM:

Customer:

Contact:

Tele:

### Questionnaire screw jacks:

Type of screw jack:

 BD BDL BDK BDKL

Number of jacks

Please attach drawing of installation if possible.

### Axial load on lifting screw

Dynamic load per screw jack - normal

kN

Dynamic load per screw jack - max

kN

Static load per screw jack - max

kN

Vibrations

 Yes No

Shock loads

 Yes No

Side loads

 Yes No

If yes, define

Type of load

Compression

Load case

I

Tension

II

Compression and Tension

III

### Environment

Ambient temperature:

°C

Placement

 Indoor Outdoor

Humidity:

%

Environment

 Corrosive Oil Dust Chemicals .....

Others, specify

### Operating cycle

Cycles/hour:

Hours/day:

Days/year:

### Lifting screw

Stroke length:

mm

Lifting speed:

mm/min

Mounting position of screw:

 Horizontal Vertical Upward Downward

Type of spindle:

 Trapezoidal Ball screw

Screw end:

 Thread Clevis Top plate Special, add drawing

Protection bellows:

 PVC Steel spiral Nothing

Protection tube on reverse side:

 Yes No

Stainless material:

 Yes No

# SERIES BD

## SELECTION GUIDE

### Standard accessories according to catalogue

- Safety nut SHM, state safety load direction:  Yes  No
- Stop nut SM:  Yes  No
- Locked against rotation:  LR (square tube)  LRK (key)
- Anti backlash ABL:  Yes  No
- Limit switch, state how many:  Yes  No
- Stainless jack body:  Yes  No
- Stainless worm screw:  Yes  No
- Stainless end fittings:  Yes  No

### Other accessories for gears

- ISO 10204:2004  2.1  2.2  3.1  3.2
- Documentation  GA  Spare part list  Section  .....
- ATEX:  Yes  No Use order template for ATEX, B 74004-1
- Transport conservation (anti-rust)  Yes  No

### Motor data:

- Standard  IEC  NEMA
- Motor type  AC  DC
- Voltage  V  Hz
- Motor flange:  No  Right mounted  Left mounted
- Brake  Yes  No  AC  DC
- Protection class  IP 54  IP 67  IP.....

### Other notes:

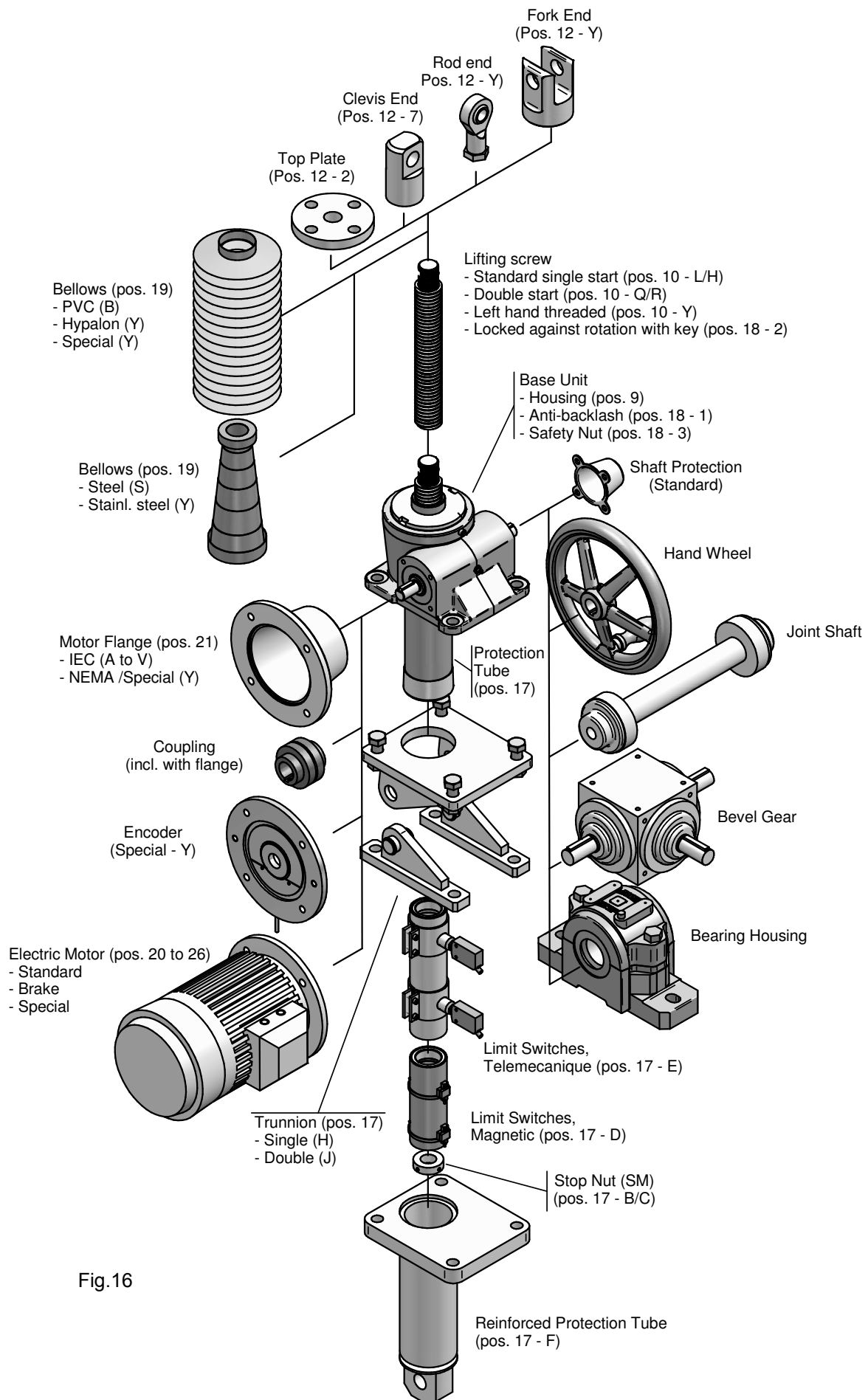



Fig.16

## PRODUCT CODIFICATION - SCREW JACKS

Jack codes																	Motor codes														
Unit description								Execution	Spindle design			Travel				Variant Options			Applicable if pos. 9 (execution code)= P, D, E, G, M, J, K, N												
Type		Size			Revision Version	Jack Execution	Ratio / Spindle Start	Direction	Spindle end	Stroke (mm)				PT/SM/LS/Trunnion	ABL / LRK / SHM	Bel lows	Motor Flange Pos	Motor Flange size	Motor Power (kW)			Terminal Box Position									
1	2	3	4	5	6	7	8	9	10	11	12	13	14	15	16	17	18	19	20	21	22	23	24	25	26						
B	D	-	-	6	6	-	/	2	/	M	/	L	U	3	/	-	7	0	0	/	D	3	B	/	R	F	0	.	7	5	A

**Pos. 1, 2, 3, 4 Type**  
**BD**- Screw Jack with Translating screw  
**BDL**- Screw Jack with Travelling nut  
**BDK**- Ball screw jack with translating screw  
**BDKL** Ball screw jack with travelling nut

**Pos. 5, 6, 7 Size**  
**66**- Sizes 27 to 200 (BD/BDL)  
 Sizes 27 to 66 (BDK/BDKL)

**Pos. 8 Revision Version**  
**2** For Sizes 27 to 86  
**1** For Sizes 100-200

**Pos. 9 Screw Jack Execution code**  
**F** Free Input Shaft  
**A** Free Input shaft+Stainless Gear Housing (HR)  
**B** Free Input shaft+Stainless Worm Screw (PR)  
**C** Free Input shaft+ Complete Stainless Steel construction (PH)  
**P** Prepared for Motor  
**D** Prepared for Motor +Stainless Gear Housing (HR)  
**E** Prepared for Motor +Stainless Worm Screw (PR)  
**G** Prepared for Motor+ Complete Stainless Steel construction (PH)  
**M** Including Motor  
**J** Including Motor +Stainless Gear Housing (HR)  
**K** Including Motor +Stainless Worm Screw (PR)  
**N** Including Motor+ Complete Stainless Steel construction (PH)  
**Y** Special (specify)

**Pos. 10 Worm set Ratio, Lifting screw thread**  
**L** Low ratio with Single start  
**H** High ratio with Single start  
**Q** Low ratio with Double start (L2)  
**R** High ratio with Double start (H2)  
**Y** Special (specify)

**Pos. 11 Lifting screw Direction**  
**U** Upright  
**N** Inverted  
**Y** Special (specify, e.g. double-ended)

**Pos. 12 Spindle end**  
**1** Threaded end  
**2** Top Plate  
**3** Clevis End  
**5** Stainless Steel Lifting screw with threaded end  
**6** Stainless Steel Lifting screw with Top Plate  
**7** Stainless Steel Lifting screw with Clevis end  
**-** BDL / BDKL standard end  
**Y** Special (specify)

**Pos. 13, 14, 15, 16 Stroke length (mm)**  
**-700** Stroke length

**Pos. 17 Variant Option 1 \*\*** (refer page 35 )  
**-** Protection tube in Aluminum (BD27-BD86)  
**S** Protection tube in Steel (BD27-BD200)  
**A** Without Protection Tube  
**B** Stop Nut SM with protection tube  
**C** Stop Nut SM without Protection Tube  
**D** Limit Switches (MLS) Magnetic (Including Stop nut)  
**E** Limit switches (LS) Tele-mecanique (Including Stop nut)  
**F** Reinforced protection tube (with clevis end, only steel)  
**G** Locked Against Rotation LR (Only Steel Protection tube)  
**H** Trunnion Single  
**J** Trunnion Double  
**Y** Special (specify)

**Pos. 26 Motor terminal box position**  
 Viewed from motor back side  
 - None (refer page 50 )  
**A** 45° (Standard)  
**B** 135° (Standard)  
**C** 225° (Standard)  
**D** 315° (Standard)  
**E** 0° (Non Standard)  
**F** 90° (Non Standard)  
**G** 180° (Non Standard)  
**H** 270° (Non Standard)

**Pos. 22, 23, 24, 25 Motor Power (kW)**  
 0.75 Motor power in kW

**Pos. 21 Motor Flange size**  
 - None  
**A** IEC63B14  
**B** IEC63B5  
**C** IEC71B14  
**D** IEC71B5  
**E** IEC80B14  
**F** IEC80B5  
**G** IEC90B14  
**H** IEC90B5  
**J** IEC100B14/ IEC112B14  
**K** IEC100B5/ IEC112B5  
**M** IEC132B14  
**N** IEC132B5  
**P** IEC160B5  
**Q** IEC180B5  
**T** IEC200B5  
**U** IEC225B5  
**V** IEC250B5  
**Y** Special (specify)

**Pos. 20 Motor Flange mounting position**  
 - None (refer page 50 )  
**R** MCH - Mounted Right  
**L** MCV - Mounted Left

**Pos. 19 Spindle protection**  
 - None  
**B** PVC Bellow  
**S** Steel Bellow (Telescopic)  
**Y** Special (specify)

**Pos. 18 Variant Option 2 \*\***  
 - None (refer page 35 )  
**1** Antibacklash ABL  
**2** Locked against rotation with Key LRK  
**3** Safety Nut SHM - (specify load direction)  
**Y** Special (specify)

\*\* - Combinations with other options contact your local sales office.

\* This page may be photocopied allowing the Customer to enter their order

Y - Special specify with position number.

For online product selection/configuration and 2D/3D models of Screw Jacks visit [www.benzlers.solidcomponents.com](http://www.benzlers.solidcomponents.com)

## DETERMINATION OF TYPE

### Position 11: Lifting screw Direction

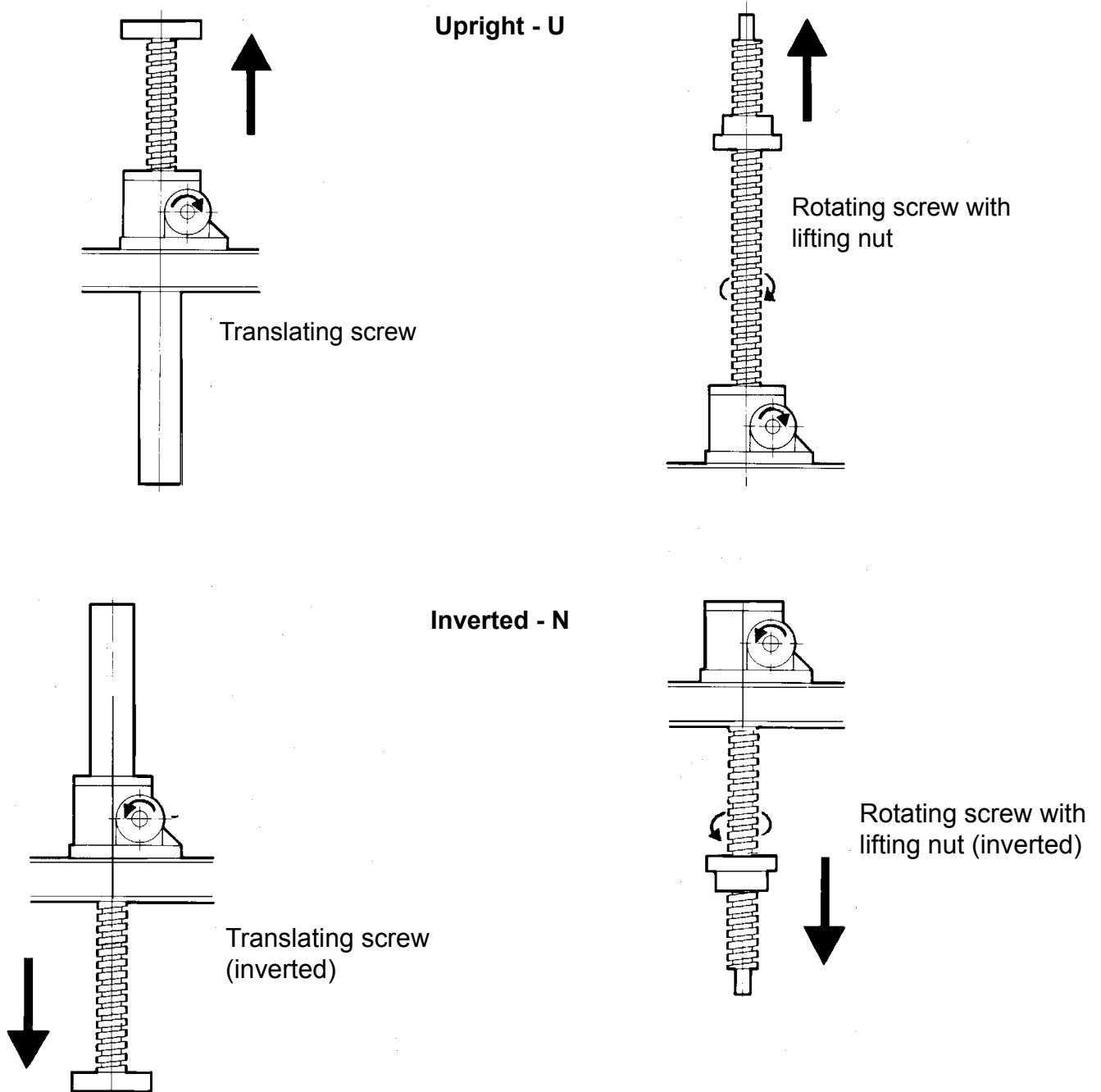

Fig. 17

Note: For types BD and BDK spindle must be held to prevent rotation. For types BDL and BDKL lifting nut must be held to prevent rotation.

## SELECTION OF JACKS

Symbols used:

F = Force (N) (1 tonne = 10 000 N)

v = Lifting speed (mm/min)

s = Pitch of lifting screw (mm)

n = Required input speed (rpm)

i = Ratio of worm gear set

ED% = Intermittence (%)

$P_d$  = Running power of screw jack (kW)

$P_s$  = Starting power of screw jack (kW)

$P_{ED}$  = Thermal power (kW)

$P_{Mnom}$  = Nominal motor power (kW)

$P_{Mst}$  = Starting power of motor (kW)

$P_{Max}$  = Max allowable input power of screw jack (kW)

$\eta_d$  = Running efficiency of screw jack

$\eta_s$  = Starting efficiency of screw jack

To calculate a screw jack you must at least know the force (F) to be moved and the lifting speed (v).

There are three types of standard format mechanical jacks.

### I. BD/BDL - Single Start

Screw jack with single start trapezoidal lifting screw available in 8 sizes, as standard.

This is the most frequently used screw jack, suitable for low lifting speeds (up to 2400 mm/min), competitively priced.

### II BD/BDL - Double Start

Screw jack with double start trapezoidal lifting screw available in 8 sizes, as standard.

Higher lifting speeds can be obtained, compared to single start lifting screw, with increased efficiency, a brake must be included in the system, as they are not self sustaining.

### III BDK/BDKL

Screw jack with ball screw lifting screw, available in 4 sizes as variants.

This type is suitable for high lifting speeds.

Owing to the higher overall efficiency, it is suited for applications with high degree of utilization required. (High ED).

Brake must be included in the system, as they are not self sustaining.

1. Select a screw jack where the nominal force is larger than the required force. (See "Technical data" on page 13-14, 40).

2. By compression load check stroke length for bending according to Loadcase I, II or III (See compression load tables 15-17,41-42)
3. Check in Power rating tables that the max allowable power or torque is not exceeded.

4. Selection of one screw jack  
Calculate the running power ( $P_d$ ) and starting power ( $P_s$ ).  $P_d$  is stated in tables, see step 3 or calculate as follows

$$P_d = \frac{F \times v}{\eta_d \times 6 \times 10^7}$$

$$P_s = \frac{F \times v}{\eta_s \times 6 \times 10^7}$$

$\eta_d$  = running efficiency (see "Power rating tables" page 18-26)

$\eta_s$  = starting efficiency (see "Technical data" page 13-14,40)

5. State the intermittence ED% in %/hour

Example: 12 min/hour = 20%

6. If ED% is other than 20% check on page 27 or 44 that the thermal power  $P_{ED}$  is not exceeded. The selection of jack is correct if  $P_{ED} > P_d$  ( $P_d$  see step 4).

7. When selecting screw jack type BDL and BDKL check critical spindle speed, see page 28 or 44.

8. Only screw jacks type BD can permit side forces (see table page 29).

9. Selection of motor:

I Check that  
Nominal motor power  $P_{Mnom} > P_d$  ( $P_d$ , see step 4)

II Check that  
Starting power of motor  $P_{Mst} > P_s$  ( $P_s$ , see step 4)

To determine the starting power of motor, following formula is used in most cases:

$$P_{Mst} = \frac{M_{st}}{M} \times P_{Mnom}$$

$\frac{M_{st}}{M}$  = factor stated in motor catalogue

Note: For three phase motor the factor  $\frac{M_{st}}{M}$  is normally 1.8 - 2.5.

10. Calculate the required input speed

$$n = \frac{v \times i}{s} \text{ (rpm)}$$

(i and s, see Technical data page 13-14, 40)

### Calculation of multi jack arrangement

To calculate a screw jack arrangement is described in a simplified way below. For a more detailed calculation consult our local Benzlers representative.

- 1) Calculate the power consumption of each single jack in the arrangement as under step 4 for single Jacks.
- 2) Add up the power consumption of each single jack to get the total power consumption,  $P_x$ .
- 3) Attention must be paid to the efficiency of the connecting shaft system and other components in the arrangement such as: Worm Gears, Bevel Gears, Helical Gears, Couplings, Bearings and normal misalignment when mounting the arrangement.  
If this is not possible use the following arrangement efficiency:

Number of jacks	$\eta_{arr}$
2	0.95
3	0.90
4	0.85
6-8	0.80

$$P_{arr} = \frac{P_x}{\eta_{arr}}$$

$P_{arr}$  = Total power consumption of the arrangement

$P_x$  = The sum of the power consumption each single jack

$\eta_{arr}$  = The efficiency of the arrangement acc to table

- 4) After calculating design motor power required, care should be taken to choose a larger motor with a safe working margin of excess power.
- 5) By high lifting speeds and high speed in connecting shaft system, the mass moment of inertia must be taken into consideration.

# SERIES BD

## GUIDE TO SELECTING SINGLE SCREW JACK ARRANGEMENTS

### Single screw jack

Load : 30 kN compression      Stroke : 500 mm  
 Load Case : II      Intermittence : 15 min/hour  
 Lifting speed : 415 mm/min      Ambient temperature : 25°C, if ambient temperature > 25°, contact your local Benzlers sales office.

1. Select a screw jack where the nominal force is larger than the required force from table below :

Load 30 kN → BD58 1-start. Max capacity for BD58 is 50 kN > 30kN

Size	58	66
Max capacity N	50000	150000
Lifting screw	Tr 40x7	Tr55x9
Ratio (L)	6.75:1	7:1
Raise per revolution (mm)	1.037	1.285
Starting torque/Handwind torque at max load (Nm)	55	210
Max running power at 20% ED (kW)	0.9	1.5
Starting efficiency $\eta_s$	0.14	0.14
Ratio (H)	27:1	28:1
Raise per revolution (mm)	0.259	0.321
Starting torque/Handwind torque at max load (Nm)	32	115
Max running power at 20% ED (kW)	0.8	1.3
Starting efficiency $\eta_s$	0.06	0.06
Starting torque on lifting screw at max load	199	810
Running efficiency $\eta_d$	0.28	0.27
Weight without spindle or protection tube BD/BDL (kg)	14/16.5	22/25
Weight of lifting screw 100 mm (kg)	0.82	1.6
Normal axial backlash (mm)	0.1-0.35	0.1-0.40

2. By compression load, check stroke length for bending according to load case I, II or III. In this case stroke 500 mm and load case II.(Page 16)  
 For BD58 the bending has no effect until free spindle length is longer than 0.8 m.

BD58	
Free Spindle Length (m)	Capacity (kN)
0.2	50
0.3	50
0.4	50
0.5	<b>50</b>
0.6	50
0.7	50
0.8	50
0.9	44
1.0	36

3. Selection of one screwjack. Calculate the running power( $P_d$ ) and starting power( $P_s$ ).

These are stated in tables pages 18-26 and 42-43 or can be calculated as follows:

$$P_d = (F \times v) / (\eta_d \times 6 \times 10^7) = (30\,000 \times 415) / (0.28 \times 6 \times 10^7) = 0.74 \text{ kW}$$

$$P_s = (F \times v) / (\eta_s \times 6 \times 10^7) = (30\,000 \times 415) / (0.14 \times 6 \times 10^7) = 1.48 \text{ kW}$$

Acc. to Power Rating tables:  $P_d = 0.73 \text{ kW}$  which is close to the calculated value.

4. Calculate intermittence in percent.  
 15 min/hour = 15/60 = 25%

5. If intermittence is >20% check that the thermal power  $P_{ED}$  is not exceeded. Thermal power  $P_{ED} > P_d$ . It can be read in table "Intermittence Factor (ED) BD/BDL" on page 27,44 or can be calculated as follows:  
 According to table , intermittence factor = 0.8 →  $P_{ED} = 0.8 \times 0.9 = 0.72 \text{ kW}$ , or  $P_{ED} = 20\%/ED\% \times P_{max} = 20/25 \times 0.9 = 0.72 \text{ kW}$

→  $P_{ED} (0.72 \text{ kW}) < P_{max} (0.74 \text{ kW})$   
 → Select BD66 low ratio (L) then do a new calculation.

6. For BD66 low ratio running and starting power are:  
 $P_d = (F \times v) / (\eta_d \times 6 \times 10^7) = (30\,000 \times 415) / (0.27 \times 6 \times 10^7) = 0.77 \text{ kW}$   
 $P_s = (F \times v) / (\eta_s \times 6 \times 10^7) = (30\,000 \times 415) / (0.14 \times 6 \times 10^7) = 1.48 \text{ kW}$

7. Check allowable side force  $F_r$  at the spindle according to table on page 29. For BD66,  $F_a = 30 \text{ kN}$  and stroke 500 mm  
 → Max side force  $F_r = \sim 2 \text{ kN}$ .

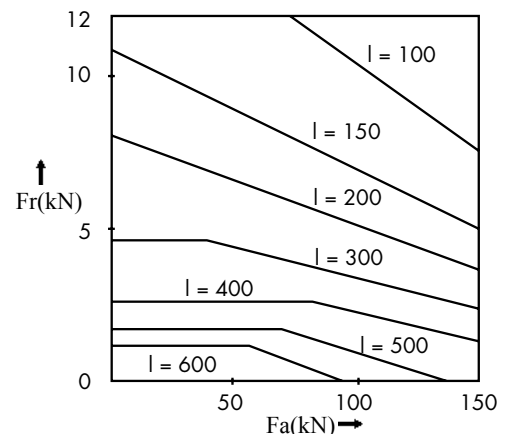
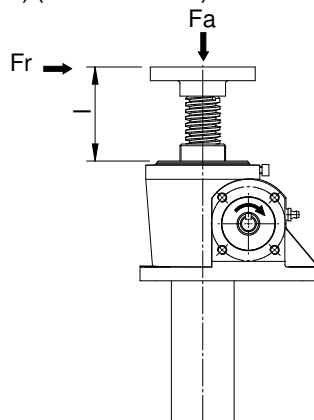

# SERIES BD

## GUIDE TO SELECTING SINGLE SCREW JACK ARRANGEMENTS

### 8. Selection of motor:

Check that nominal motor power  $P_{Mnom} >$  running power  $P_d (=0.77 \text{ kW})$   
 Check that starting power motor  $P_{Mst} >$  starting power  $P_s (=1.48 \text{ kW})$ .  
 To determine the starting power of motor, the following formula is used in most cases:

$P_{Mst} = P_{Mnom} \times (M_{st}/M)$   
 $M_{st}$  = Starting torque motor  
 $M$  = nominal torque motor  
 $M_{st}/M$  = factor stated in motor catalogue.  
 For three phase motor the factor  $M_{st}/M$  is normally 1.8-2.5  
 Calculate the required input speed:

$n = (v \times i) / s = (415 \times 7) / 9 = 323 \text{ rpm}$   
 $v$  = lifting speed (mm/min)  
 $i$  = ratio of worm gear  
 $s$  = pitch of lifting screw.

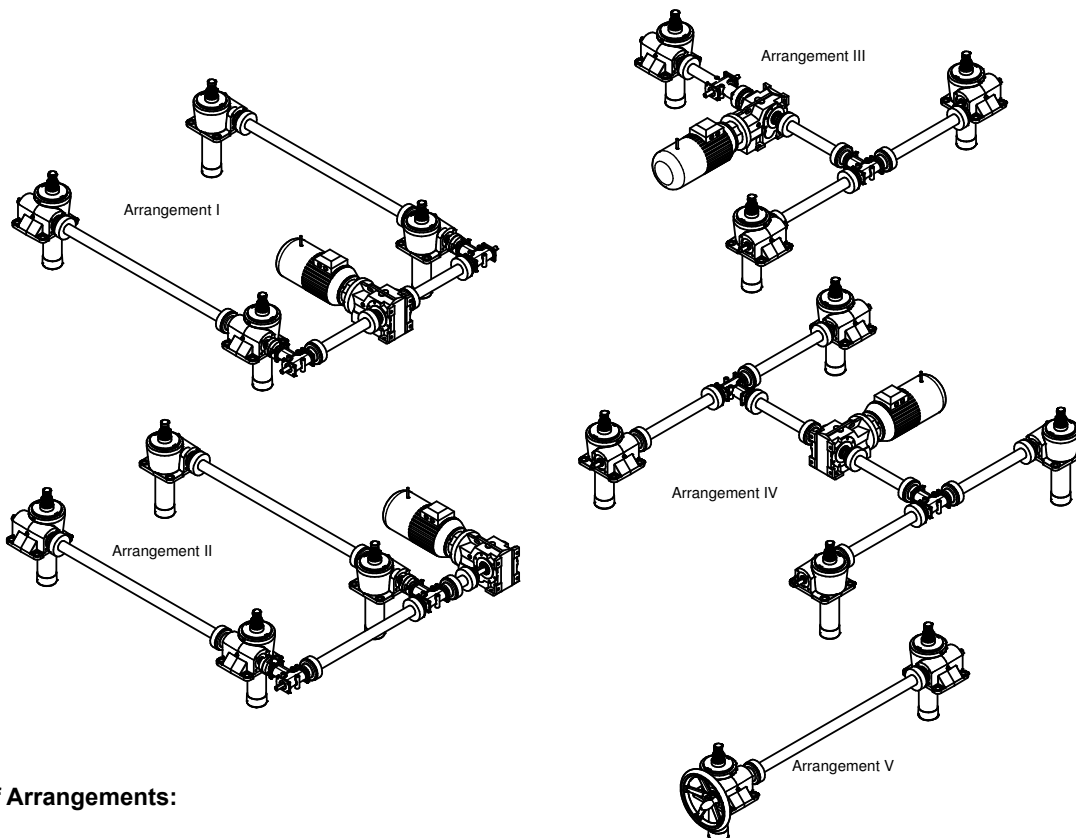

### Example of Arrangements:

1. Running power consumption for each screw jack = 0.77 kW according to calculation above.

Starting power consumption for each screw jack = 1.48 kW according to calculation above.

2. Add up the power- and starting consumption for each screw jack to get the total power- and starting consumption power  $P_x$  and  $P_{xst}$ .  
 For arrangement with 4 screw jacks:

$$P_x = 4 \times 0.77 = 3.08 \text{ kW}$$

$$P_{xst} = 4 \times 1.48 = 5.92 \text{ kW}$$

3. Take consideration to the efficiency of the connection shaft system and other components such as Worm Gears, Bevel Gears, Helical gears, Couplings, Bearings etc.

If this is not possible, use the following arrangement efficiency:

Number of screw jacks	$\eta_{arr}$
2	0.95
3	0.90
4	0.85
6-8	0.80

$$P_{arr} = P_x / \eta_{arr}$$

$$P_{arrst} = P_{xst} / \eta_{arr}$$

$P_{arr}$  = Total running power of consumption of the arrangement

$P_x$  = The sum of the running power consumption for each single jack

$P_{arrst}$  = Total starting power of consumption of the arrangement

$P_{xst}$  = The sum of the starting power consumption for each single jack

$\eta_{arr}$  = The efficiency of the arrangement according to table above

For 4 screw jacks total running- and starting power for the arrangement is

$$P_{arr} = P_x / \eta_{arr} = 3.08 / 0.85 = 3.59 \text{ kW}$$

$$P_{arrst} = P_{xst} / \eta_{arr} = 5.92 / 0.85 = 6.96 \text{ kW}$$

4. Calculate motor power required in the same way as for single screw jack. Care should be taken to choose a larger motor with a safe working margin of excess power.

Check that total nominal motor power  $P_{Mnom \text{ arr}} >$  running power  $P_{arr} (=3.59 \text{ kW})$ .

Check that total starting motor power  $P_{Mst \text{ arr}} >$  starting power  $P_{arrst} (=6.96 \text{ kW})$ .

5. By high lifting speeds and high speed in connection shaft system, the mass moment of inertia must be taken into consideration.



## TECHNICAL DATA : BD - BDL

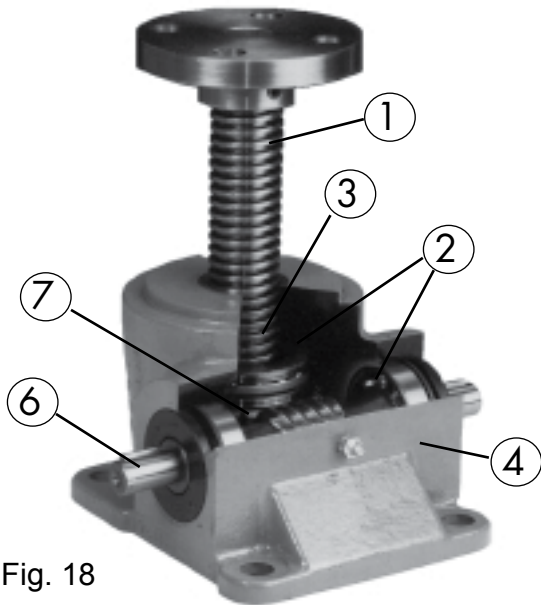

Fig. 18

- 1 Trapezoidal lifting screw
- 2 Thrust and radial bearings
3. Grease of EP-quality
4. Housing of nodular cast iron
5. Alkyd paint 85 micron thick in RAL 5009
6. Worm screw hardened and ground
7. Worm wheel of centrifugally cast tin bronze
8. Bellows in PVC, steel or other materials(Not shown in picture)
9. Protection tube in Steel/Aluminium(Not shown in picture)
10. Protection cover for input shaft on non drive end (Not shown in picture)

Mechanical jacks have an allowable working temperature range from -30° C to +100° C. At full load the degree of utilization (ED) must not normally exceed 40% per 10 minutes and still not more than 20% per hour totally. Valid at ambient temperature +25° C.

### Technical data, single start spindle

For other conditions consult Benzlers local sales office.

Size	27	40	58	66	86	100	125	200
Max capacity N	10000	25000	50000	150000	200000	300000	500000	1000000
Lifting screw	Tr 20x4	Tr 30x6	Tr 40x7	Tr55x9	Tr 65x10	Tr 90x12	Tr120x14	Tr160x16
Ratio (L)	9:1	7:1	6.75:1	7:1	7:1	7:1	7.5:1	12:1
Raise per revolution (mm)	0.444	0.857	1.037	1.285	1.428	1.714	1.866	1.333
Starting torque/Handwind torque at max load (Nm)	6	23	55	210	320	640	1280	2235
Max running power at 20% ED (kW)	0.2	0.55	0.9	1.5	2.9	3.7	5.1	12.5
Starting efficiency $\eta_s$	0.12	0.15	0.14	0.14	0.14	0.12	0.11	0.09
Ratio (H)	27:1	30:1	27:1	28:1	28:1	28:1	30:1	36:1
Raise per revolution (mm)	0.148	0.200	0.259	0.321	0.357	0.428	0.466	0.444
Starting torque/Handwind torque at max load (Nm)	5	10	32	115	160	320	640	1335
Max running power at 20% ED (kW)	0.15	0.5	0.8	1.3	2.6	3.3	4.5	12
Starting efficiency $\eta_s$	0.05	0.08	0.06	0.06	0.07	0.06	0.05	0.05
Starting torque on lifting screw at max load	21	77	199	810	1261	2548	5535	14425
Running efficiency $\eta_d$	See Power ratings BD - BDL							
Weight without spindle or protection tube BD/BDL (kg)	2/2.4	7/8	14/16.5	22/25	41/49	73/85	134/162	450
Weight of lifting screw 100 mm (kg)	0.2	0.45	0.82	1.6	2.2	4.4	7.9	14
Normal axial backlash* (mm)	0.1-0.25	0.1-0.30	0.1-0.35	0.1-0.40	0.1-0.40	0.1-0.45	0.15-0.45	0.15-0.50

(\*Antibacklash see Options)

# SERIES BD

## TECHNICAL DATA : BD - BDL

### Technical Data, Double Start Spindle

Size	27	40	58	66	86	100	125	200
Max capacity N	8000	20000	40000	120000	160000	240000	400000	800000
Lifting screw	Tr 20x8	Tr 30x12	Tr 40x14	Tr55x18	Tr 65x20	Tr 90x24	Tr120x28	Tr160x32
Ratio (L)	9:1	7:1	6.75:1	7:1	7:1	7:1	7.5:1	12:1
Raise per revolution (mm)	0.888	1.714	2.074	2.571	2.857	3.428	3.733	2.667
Starting torque/Handwind torque at max load (Nm)	6	23	55	210	320	640	1280	2120
Max running power at 20% ED (kW)	0.25	0.7	1.1	1.9	3.6	4.7	6.4	16.0
Starting efficiency $\eta_s$	0.18	0.23	0.23	0.22	0.22	0.20	0.19	0.16
Ratio (H)	27:1	30:1	27:1	28:1	28:1	28:1	30:1	36:1
Raise per revolution (mm)	0.296	0.400	0.518	0.642	0.714	0.856	0.932	0.889
Starting torque/Handwind torque at max load (Nm)	4.8	10.1	32.5	117	164	323	624	1265
Max running power at 20% ED (kW)	0.20	0.60	1.0	1.6	3.2	4.1	5.6	15.0
Starting efficiency $\eta_s$	0.07	0.12	0.10	0.10	0.11	0.10	0.09	0.08
Starting torque on lifting screw at max load	22	82	206	648	1276	2518	5358	13660
Running efficiency $\eta_d$	See Power ratings BD - BDL							
* Holding Torque Nm	0.35	1.8	5.5	16	24	44	80	115
Weight without spindle or protection tube BD/BDL (kg)	2/2.4	7/8	14/16.5	22/25	41/49	73/85	134/162	450
Weight of lifting screw 100 mm (kg)	0.2	0.45	0.82	1.6	2.2	4.4	7.9	14
Normal axial backlash (mm)	0.1-0.25	0.1-0.30	0.1-0.35	0.1-0.40	0.1-0.40	0.1-0.45	0.15-0.45	0.15-0.50

\* The holding torque is the torque on the input shaft which is required to prevent the load from being lowered.

### Technical Data, Static Load

Maximum allowed static load (kN) (at tension loads in lifting screw)

Size	27	40	58	66	86	100	125	200
Dynamic Capacity	10	25	50	150	200	300	500	1000
BD, static	19.5	52.5	117.5	180	255	474	900	1320
BDL, static	17.5	41	88	180	240	300	500	1000

Above values can be allowed when the load is still. Under movement or when vibrations can occur the dynamic values are valid. At all cases with compression load the values in the "compression load table BD - BDL" on pages 15-17 must not be exceeded.

### Maximum Length for Horizontal Installations

Below table shows Maximum Length for Horizontal Screwjack installations. The lengths are based on the assumption screwjacks will be installed as shown in Fig 17. For other types of installations, please contact your local Benzlers sales office.

Size	Lmax (mm)
BD27	1141
BD40	1517
BD58	1914
BD66	2399
BD86	2744
BD100	3483
BD125	4296

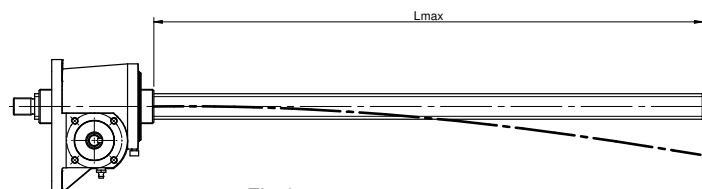
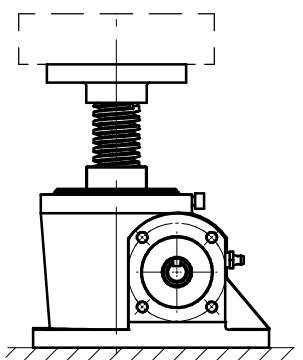

Fig 17

# SERIES BD

## COMPRESSION LOAD TABLE

### BD - BDL LOAD CASE I

Size	27	40	58	66	86	100	125	200	
Max capacity (kN)	10	25	50	150	200	300	500	1000	
<p>Max capacity, compression load (kN) for different lengths of stroke at three-fold safety factor against breaking (Loadcase I)</p> <p style="text-align: center;"><i>Free load</i></p>  <p style="text-align: center;">Fig. 19</p>	0.2	*	*	*	*	*	*	*	
	0.3	5.4	*	*	*	*	*	*	
	0.4	(3.1)	15	*	*	*	*	*	
	0.5		9.5	36	139	*	*	*	
	0.6		(6.6)	25	96	*	*	*	
	0.7		(4.8)	18	71	147	*	*	
	0.8			14	54	112	*	*	
	0.9			(11)	43	89	*	*	
	1.0			(8.9)	35	72	298	*	
	1.25				(22)	46	190	*	
	1.5					(32)	132	440	*
	1.75						97	323	*
	2.0						(74)	248	860
	2.25						(59)	196	680
	2.5							158	551
	2.75							(131)	455
	3.0							(110)	382
	3.25							(94)	326
	3.5								281
	3.75								(245)
	4.0								(215)
4.25								(191)	
4.5									
4.75									
5.0									
5.5									
6.0									
6.5									
7.0									
7.5									
8.0									

The values given in brackets must only be used at low lifting speed and concentric load on the lifting screws.

\* Maximum Capacity

# SERIES BD

## COMPRESSION LOAD TABLE BD - BDL LOAD CASE II

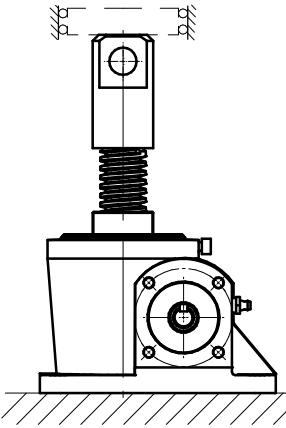
Size	27	40	58	66	86	100	125	200	
Max capacity (kN)	10	25	50	150	200	300	500	1000	
<p>Max capacity, compression load (kN) for different lengths of stroke at three-fold safety factor against breaking (Loadcase II)</p> <p style="text-align: center;"><i>Guided load</i></p>  <p style="text-align: center;">Fig. 20</p>	0.2	*	*	*	*	*	*	*	
	0.3	*	*	*	*	*	*	*	
	0.4	*	*	*	*	*	*	*	
	0.5	7.8	*	*	*	*	*	*	
	0.6	5.4	*	*	*	*	*	*	
	0.7	4.0	19	*	*	*	*	*	
	0.8	(3.1)	15	*	*	*	*	*	
	0.9	(2.4)	12	44	*	*	*	*	
	1.0		9.5	36	139	*	*	*	
	1.25		(6.1)	23	89	184	*	*	
	1.5			16	62	128	*	*	
	1.75			(12)	45	94	*	*	
	2.0				35	72	298	*	
	2.25				27	57	235	*	
	2.5				(22)	46	190	*	
	2.75				(18)	(38)	157	*	
	3.0					(32)	132	440	
	3.25					(27)	113	375	
	3.5						97	323	
	3.75						85	282	979
	4.0						(74)	248	860
	4.25						(66)	219	762
	4.5						(59)	196	680
	4.75							176	610
	5.0							158	551
	5.5							(131)	455
	6.0							(110)	382
	6.5							(94)	326
7.0								281	
7.5								(245)	
8.0								(215)	

The values given in brackets must only be used at low lifting speed and concentric load on the lifting screws.

\* Maximum Capacity

# SERIES BD

## COMPRESSION LOAD TABLE

### BD - BDL LOAD CASE III

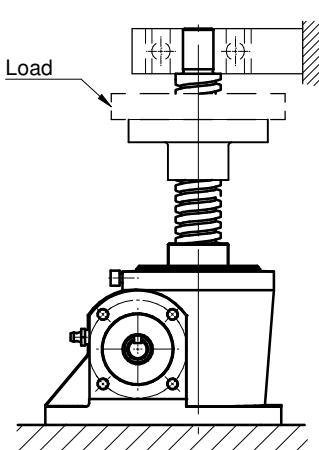
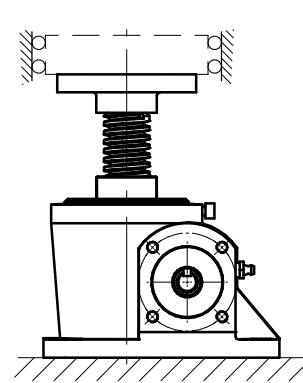
Size	27	40	58	66	86	100	125	200
Max capacity (kN)	10	25	50	150	200	300	500	1000
<p>Max capacity, compression load (kN) for different lengths of stroke at three-fold safety factor against breaking (Loadcase III)</p> <p style="text-align: center;"><i>Supported spindle</i></p>  <p style="text-align: center;"><i>Guide load</i></p>  <p style="text-align: center;">Fig. 21</p>	0.2	*	*	*	*	*	*	*
	0.3	*	*	*	*	*	*	*
	0.4	*	*	*	*	*	*	*
	0.5	*	*	*	*	*	*	*
	0.6	*	*	*	*	*	*	*
	0.7	8.0	*	*	*	*	*	*
	0.8	6.1	*	*	*	*	*	*
	0.9	4.8	23	*	*	*	*	*
	1.0	3.9	19	*	*	*	*	*
	1.25	(2.5)	12	45	*	*	*	*
	1.5		8.4	32	123	*	*	*
	1.75		(6.2)	23	91	188	*	*
	2.0		(4.7)	18	69	144	*	*
	2.25			14	55	114	*	*
	2.5			(11)	44	92	*	*
	2.75			(9.4)	37	76	*	*
	3.0				31	64	265	*
	3.25				(26)	55	225	*
	3.5				(23)	47	194	*
	3.75				(20)	(41)	169	*
	4.0				(17)	(36)	149	495
4.25					(32)	132	439	
4.5					(28)	118	391	
4.75					(25)	105	351	
5.0						95	317	
5.5						79	262	910
6.0						(66)	220	765
6.5						(56)	188	652
7.0							162	562
7.5							(141)	490
8.0							(124)	430

The values given in brackets must only be used at low lifting speed and concentric load on the lifting screws.

\* Maximum Capacity

## POWER RATINGS BD-BDL SINGLE START SPINDLE

**Power ratings for BD-BDL with single start spindle at 40% ED/10 min or max 20% ED/hour at ambient temperature +25° C.**

n = input speed (rpm)  
 v = lifting speed (mm/min)  
 $\eta_d$  = running efficiency  
 L = low ratio  
 H = high ratio  
 T = input torque (Nm)  
 P = input power (kW)  
 i = ratio of worm gear set

**Note:** Power ratings indicate running power. Additional power will be required on start. See "Selection of jacks" on page 10.

**Mechanical and Thermal capacities:**

- A) Mechanical capacity: all stated values non blank areas in tables.
- B) Mechanical capacity with stainless worm screw: Grey areas in tables
- C) Thermal capacity:  
 The figures above the line in ***Italics*** can only be used at ED lower than 20%. Thermal power must be checked. See "Intermittence factor (ED) BD/BDL" on page 27.

### BD 27 L (i = 9) H (i = 27) TR 20 x 4 (Single start)

n rpm	v mm/min		$\eta_d$		10 kN				8 kN				6 kN				4 kN			
	L	H	L	H	TLP		THP		TLP		THP		TLP		THP		TLP		THP	
					Nm	kW	Nm	kW	Nm	kW	Nm	kW	Nm	kW	Nm	kW	Nm	kW	Nm	kW
2900	1289	430	.31	.18	<b>2.2</b>	<b>.68</b>	<b>1.3</b>	<b>.38</b>	<b>1.8</b>	<b>.56</b>	<b>1.1</b>	<b>.32</b>	<b>1.4</b>	<b>.44</b>	<b>.88</b>	<b>.26</b>	<b>1.0</b>	<b>.32</b>	<b>.66</b>	<b>.20</b>
1750	778	259	.29	.16	<b>2.4</b>	<b>.44</b>	<b>1.4</b>	<b>.25</b>	<b>2.0</b>	<b>.36</b>	<b>1.2</b>	<b>.21</b>	<b>1.5</b>	<b>.28</b>	<b>.94</b>	<b>.17</b>	1.1	.20	.70	.13
1500	667	222	.28	.16	<b>2.5</b>	<b>.39</b>	<b>1.4</b>	<b>.22</b>	<b>2.0</b>	<b>.32</b>	<b>1.2</b>	<b>.18</b>	<b>1.6</b>	<b>.25</b>	<b>.94</b>	<b>.15</b>	1.1	.18	.70	.11
1000	444	148	.26	.15	<b>2.7</b>	<b>.28</b>	<b>1.5</b>	<b>.16</b>	<b>2.2</b>	<b>.23</b>	<b>1.2</b>	<b>.13</b>	<b>1.7</b>	<b>.18</b>	<b>1.0</b>	<b>.11</b>	1.2	.13	.74	.08
750	333	111	.25	.14	<b>2.8</b>	<b>.22</b>	<b>1.6</b>	<b>.13</b>	<b>2.3</b>	<b>.18</b>	<b>1.3</b>	<b>.11</b>	<b>1.8</b>	<b>.14</b>	<b>1.1</b>	<b>.09</b>	1.3	.10	.78	.06
500	222	74	.23	.13	<b>3.0</b>	<b>.16</b>	<b>1.8</b>	<b>.09</b>	<b>2.4</b>	<b>.13</b>	<b>1.5</b>	<b>.07</b>	<b>1.9</b>	<b>.10</b>	<b>1.2</b>	<b>.06</b>	1.3	.07	.86	.05
400	178	59	.22	.12	<b>3.1</b>	<b>.13</b>	<b>1.9</b>	<b>.08</b>	<b>2.5</b>	<b>.11</b>	<b>1.6</b>	<b>.07</b>	<b>2.0</b>	<b>.08</b>	<b>1.2</b>	<b>.05</b>	1.4	.06	.90	.05
300	133	44	.21	.11	<b>3.2</b>	<b>.10</b>	<b>2.0</b>	<b>.06</b>	<b>2.6</b>	<b>.08</b>	<b>1.6</b>	<b>.05</b>	<b>2.0</b>	<b>.06</b>	<b>1.3</b>	<b>.05</b>	1.4	.05	.94	.05
200	89	30	.20	.10	<b>3.4</b>	<b>.07</b>	<b>2.2</b>	<b>.05</b>	<b>2.8</b>	<b>.06</b>	<b>1.8</b>	<b>.05</b>	<b>2.1</b>	<b>.05</b>	<b>1.4</b>	<b>.05</b>	1.5	.05	1.0	.05
100	44	15	.18	.09	<b>3.8</b>	<b>.05</b>			<b>3.1</b>	<b>.05</b>	<b>2.0</b>	<b>.05</b>	<b>2.4</b>	<b>.05</b>	<b>1.6</b>	<b>.05</b>	1.7	.05	1.1	.05
50	22	7	.17	.08					<b>3.3</b>	<b>.05</b>	<b>2.3</b>	<b>.05</b>	<b>2.6</b>	<b>.05</b>	<b>1.8</b>	<b>.05</b>	1.8	.05	1.3	.05

n rpm	v mm/min		$\eta_d$		2 kN				1 kN			
	L	H	L	H	TLP		THP		TLP		THP	
					Nm	kW	Nm	kW	Nm	kW	Nm	kW
2900	1289	430	.31	.18	.63	.19	.45	.13	.44	.13	.35	.10
1750	778	259	.29	.16	.67	.12	.47	.09	.46	.08	.36	.06
1500	667	222	.28	.16	.69	.11	.47	.07	.47	.07	.36	.06
1000	444	148	.26	.15	.73	.08	.49	.05	.49	.05	.37	.05
750	333	111	.25	.14	.75	.06	.51	.05	.50	.05	.38	.05
500	222	74	.23	.15	.79	.05	.55	.05	.52	.05	.40	.05
400	178	59	.22	.12	.81	.05	.57	.05	.55	.05	.41	.05
300	133	44	.21	.11	.85	.05	.59	.05	.54	.05	.42	.05
200	89	30	.20	.10	.87	.05	.63	.05	.56	.05	.44	.05
100	44	15	.18	.09	.95	.05	.69	.05	.60	.05	.47	.05
50	22	7	.17	.08	1.0	.05	.75	.05	.63	.05	.50	.05

## POWER RATINGS BD-BDL SINGLE START SPINDLE

### BD 40 L (i = 7) H (i = 30) TR 30 x 6 (Single start)

n rpm	v mm/min		$\eta_d$		25 kN				20 kN				15 kN				10 kN			
	L	H	L	H	TLP Nm	THP kW	TLP Nm	THP kW	TLP Nm	THP kW	TLP Nm	THP kW	TLP Nm	THP kW	TLP Nm	THP kW	TLP Nm	THP kW		
2600	2229		.38		<b>8.9</b>	<b>2.4</b>			<b>7.2</b>	<b>1.9</b>			<b>5.5</b>	<b>1.5</b>			<b>3.8</b>	<b>1.0</b>		
1750	1500	350	.36	.22	<b>9.4</b>	<b>1.7</b>	<b>3.5</b>	<b>.64</b>	<b>7.6</b>	<b>1.4</b>	<b>2.9</b>	<b>.52</b>	<b>5.8</b>	<b>1.0</b>	2.2	.41	<b>4.0</b>	<b>.72</b>	1.6	.29
1500	1286	300	.35	.22	<b>9.6</b>	<b>1.5</b>	<b>3.6</b>	<b>.56</b>	<b>7.7</b>	<b>1.2</b>	2.9	.46	<b>5.9</b>	<b>.92</b>	2.3	.36	<b>4.0</b>	<b>.63</b>	1.6	.26
1000	857	200	.33	.20	<b>10</b>	<b>1.1</b>	3.9	.40	<b>8.3</b>	<b>.89</b>	3.2	.33	<b>6.3</b>	<b>.67</b>	2.5	.25	4.3	.46	1.8	.18
750	643	150	.31	.19	<b>11</b>	<b>.84</b>	4.1	.32	<b>8.7</b>	<b>6.8</b>	3.3	.26	6.6	.51	2.6	.20	4.5	.35	1.8	.14
500	429	100	.29	.18	<b>12</b>	<b>.60</b>	4.4	.23	9.3	.48	3.6	.19	7.0	.37	2.8	.15	4.8	.25	2.0	0.1
400	343	80	.28	.17	12	.50	4.6	.19	9.6	.40	3.7	.15	7.3	.31	2.9	.12	5.0	.21	2.0	.08
300	257	60	.27	.16	13	.39	4.8	.15	10	.31	3.9	.12	7.6	.24	3.0	.09	5.2	.16	2.1	.07
200	171	40	.25	.15	13	.28	5.2	.11	11	.23	4.2	.09	8.1	.17	3.3	.07	5.5	.12	2.3	.05
100	86	20	.23	.13	15	.15	5.8	.06	12	.12	4.7	.05	9.0	.09	3.6	.05	6.1	.06	2.5	.05
50	43	10	.21	.12	16	.08	6.5	.05	12	.06	5.3	.05	9.8	.05	4.0	.05	6.6	.05	2.8	.05

n rpm	v mm/min		$\eta_d$		7.5 kN				5 kN				2.5 kN			
	L	H	L	H	TLP Nm	THP kW	TLP Nm	THP kW	TLP Nm	THP kW	TLP Nm	THP kW	TLP Nm	THP kW	TLP Nm	THP kW
2600	2229		.38	.24	<b>2.9</b>	<b>.79</b>			2.1	.55			1.2	.32		
1750	1500	350	.36	.22	3.1	.55	1.3	.24	2.2	.39	.98	.18	1.2	.23	.66	.12
1500	1286	300	.35	.22	3.1	.49	1.3	.21	2.2	.34	1.0	.16	1.3	.20	.67	.10
1000	857	200	.33	.20	3.3	.36	1.4	.15	2.3	.25	1.1	.11	1.3	.14	.70	.07
750	643	150	.31	.19	3.5	.27	1.5	.11	2.4	.19	1.1	.09	1.4	.11	.72	.06
500	429	100	.29	.18	3.7	.19	1.6	.08	2.6	.13	1.2	.06	1.5	.08	.75	.05
400	343	80	.28	.17	3.8	.16	1.6	.07	2.7	.11	1.2	.05	1.5	.06	.77	.05
300	257	60	.27	.16	4.0	.12	1.7	.05	2.8	.09	1.2	.05	1.6	.05	.79	.05
200	171	40	.25	.15	4.2	.09	1.8	.05	2.9	.06	1.3	.05	1.6	.05	.83	.05
100	86	20	.23	.13	4.7	.05	2.0	.05	3.2	.05	1.4	.05	1.8	.05	.89	.05
50	43	10	.21	.12	5.1	.05	2.2	.05	3.5	.05	1.6	.05	1.9	.05	.96	.05

### BD 58 L (i = 6.75) H (i = 27) TR 40 x 7 (Single start)

n rpm	v mm/min		$\eta_d$		50 kN				40 kN				30 kN				25 kN			
	L	H	L	H	TLP Nm	THP kW	TLP Nm	THP kW	TLP Nm	THP kW	TLP Nm	THP kW	TLP Nm	THP kW	TLP Nm	THP kW	TLP Nm	THP kW		
2000	2074		.36	.21									<b>14</b>	<b>2.8</b>			<b>11</b>	<b>2.4</b>		
1750	1815	454	.35	.22			<b>9.0</b>	<b>1.7</b>			<b>7.3</b>	<b>1.4</b>	<b>14</b>	<b>2.5</b>	<b>5.6</b>	<b>1.1</b>	<b>12</b>	<b>2.1</b>	<b>4.8</b>	<b>.90</b>
1500	1556	389	.35	.22			<b>9.3</b>	<b>1.5</b>			<b>7.5</b>	<b>1.2</b>	<b>14</b>	<b>2.2</b>	<b>5.8</b>	<b>.93</b>	<b>12</b>	<b>1.8</b>	<b>4.9</b>	<b>.79</b>
1000	1037	259	.33	.20			<b>10</b>	<b>1.1</b>	<b>20</b>	<b>2.1</b>	<b>8.2</b>	<b>.89</b>	<b>15</b>	<b>1.6</b>	6.3	.68	<b>13</b>	<b>1.3</b>	5.3	.58
750	778	194	.31	.19			<b>11</b>	<b>.84</b>	<b>21</b>	<b>1.6</b>	8.7	.68	<b>16</b>	<b>1.2</b>	6.6	.53	<b>13</b>	<b>1.0</b>	5.6	.44
500	519	130	.29	.17	<b>28</b>	<b>1.5</b>	12	.61	<b>22</b>	<b>1.2</b>	9.5	.49	<b>17</b>	<b>.91</b>	7.2	.38	14	.76	6.1	.32
400	415	104	.28	.16	<b>29</b>	<b>1.2</b>	12	.51	<b>23</b>	<b>.96</b>	9.9	.41	17	.73	7.5	.31	15	.61	6.4	.27
300	311	78	.27	.15	<b>30</b>	<b>.95</b>	13	.41	24	.76	11	.33	18	.58	8.0	.25	15	.48	6.8	.21
200	207	52	.25	.14	32	.67	14	.30	26	.54	11	.24	19	.41	8.7	.18	16	.34	7.4	.16
100	104	26	.23	.12	36	.37	16	.17	29	.30	13	.14	22	.22	10	.10	18	.19	8.4	.09
50	52	13	.21	.11	39	.21	19	.10	31	.17	15	.08	24	.13	11	.06	20	.11	9.5	.05

n rpm	v mm/min		$\eta_d$		20 kN				15 kN				10 kN			
	L	H	L	H	TLP Nm	THP kW	TLP Nm	THP kW	TLP Nm	THP kW	TLP Nm	THP kW	TLP Nm	THP kW	TLP Nm	THP kW
2000	2074		.36	.21	<b>9.2</b>	<b>1.9</b>			<b>7.0</b>	<b>1.5</b>			<b>4.8</b>	<b>1.0</b>		
1750	1815	454	.35	.22	<b>9.4</b>	<b>1.7</b>	3.9	.74	<b>7.2</b>	<b>1.3</b>	3.1	.58	4.9	.90	2.2	.42
1500	1556	389	.35	.22	<b>9.6</b>	<b>1.5</b>	4.0	.65	<b>7.3</b>	<b>1.1</b>	3.2	.51	5.0	.79	2.3	.36
1000	1037	259	.33	.20	<b>10</b>	<b>1.1</b>	4.3	.47	7.7	.82	3.4	.37	5.3	.57	2.4	.26
750	778	194	.31	.19	11	.82	4.6	.36	8.1	.63	3.6	.28	5.6	.43	2.6	.20
500	519	130	.29	.17	11	.62	5.0	.26	8.6	.47	3.9	.20	5.9	.32	2.8	.14
400	415	104	.28	.16	12	.49	5.2	.22	9.0	.38	4.0	.17	6.2	.26	2.9	.12
300	311	78	.27	.15	12	.39	5.5	.17	9.4	.30	4.3	.13	6.4	.20	3.0	.09
200	207	52	.25	.14	13	.27	6.0	.13	10	.21	4.6	.10	6.8	.14	3.3	.07
100	104	26	.23	.12	15	.15	6.8	.07	11	.11	5.3	.05	7.6	.08	3.7	.05
50	52	13	.21	.11	16	.09	7.7	.05	12	.06	5.9	.05	8.3	.05	4.1	.05

# SERIES BD

## POWER RATINGS BD-BDL SINGLE START SPINDLE

### BD 66 L (i = 7) H (i = 28) TR 55 x 9 (Single start)

n rpm	v mm/min L H		$\eta_d$ L H		150 kN				125 kN				100 kN				75 kN			
					TLP		THP		TLP		THP		TLP		THP		TLP		THP	
					Nm	kW	Nm	kW	Nm	kW	Nm	kW	Nm	kW	Nm	kW	Nm	kW	Nm	kW
1750	2250	563	.36	.23															<b>16</b>	<b>3.0</b>
1500	1929	482	.35	.23															<b>17</b>	<b>2.6</b>
1000	1286	321	.33	.21															<b>18</b>	<b>1.9</b>
750	964	241	.32	.19													<b>48</b>	<b>3.7</b>	<b>19</b>	<b>1.5</b>
500	643	161	.31	.18										<b>28</b>	<b>1.5</b>	<b>51</b>	<b>2.7</b>	21	1.1	
300	386	96	.27	.16									<b>74</b>	<b>2.3</b>	31	.98	<b>56</b>	<b>1.7</b>	24	.74
250	321	80	.26	.15									<b>76</b>	<b>2.0</b>	32	.85	<b>57</b>	<b>1.5</b>	24	.64
200	257	64	.25	.15									<b>79</b>	<b>1.7</b>	34	.71	60	1.3	26	.54
150	193	48	.24	.14					<b>104</b>	<b>1.6</b>	45	.71	83	1.3	36	.57	62	.96	27	.43
125	161	40	.23	.13					<b>107</b>	1.4	47	.61	85	1.1	37	.49	64	.84	28	.37
100	129	32	.23	.13	133	1.4			111	1.2	49	.51	89	.94	39	.41	67	.70	30	.31
50	64	16	.20	.11	146	.77	67	.35	122	.64	56	.29	98	.51	45	.23	73	.39	34	.18

n rpm	v mm/min L H		$\eta_d$ L H		50 kN				25 kN				20 kN				10 kN			
					TLP		THP		TLP		THP		TLP		THP		TLP		THP	
					Nm	kW	Nm	kW	Nm	kW	Nm	kW	Nm	kW	Nm	kW	Nm	kW	Nm	kW
1750	2250	563	.36	.23	<b>28</b>	<b>5.1</b>	<b>11</b>	<b>2.0</b>	<b>14</b>	<b>2.6</b>	5.8	1.1	<b>12</b>	<b>2.1</b>	4.8	.88	6.1	1.1	2.7	.50
1500	1929	482	.35	.23	<b>29</b>	<b>4.5</b>	<b>11</b>	<b>1.8</b>	<b>15</b>	<b>2.3</b>	6.0	.93	<b>12</b>	<b>1.9</b>	4.9	.76	6.2	.98	2.7	.43
1000	1286	321	.33	.21	<b>30</b>	<b>3.2</b>	12	1.3	<b>16</b>	<b>1.6</b>	6.4	.68	13	1.3	5.3	.55	6.6	.69	2.9	.31
750	964	241	.32	.19	<b>32</b>	<b>2.5</b>	13	1.0	16	1.3	6.8	.53	13	1.0	5.6	.43	6.9	.54	3.1	.24
500	643	161	.31	.18	<b>34</b>	<b>1.8</b>	14	.77	17	.92	7.4	.40	14	.74	6.1	.33	7.3	.38	3.3	.17
300	386	96	.27	.16	<b>37</b>	<b>1.2</b>	16	.50	19	.59	8.3	.26	15	.48	6.7	.21	7.9	.25	3.7	.11
250	321	80	.26	.15	38	1.0	17	.43	20	.51	8.6	.22	16	.41	7.0	.18	8.2	.21	3.8	.10
200	257	64	.25	.15	40	.86	17	.36	20	.43	9.0	.19	16	.35	7.3	.15	8.5	.18	3.9	.08
150	193	48	.24	.14	42	.65	18	.29	21	.33	9.5	.15	17	.26	7.7	.12	8.8	.14	4.2	.07
125	161	40	.23	.13	43	.56	19	.25	22	.29	9.8	.13	18	.23	8.0	.10	9.1	.12	4.3	.06
100	129	32	.23	.13	45	.47	20	.21	23	.24	10	.11	18	.19	8.3	.09	9.4	.10	4.5	.05
50	64	16	.20	.11	49	.26	23	.12	25	.13	12	.06	20	.11	9.4	.05	10	.05	5.0	.05

### BD 86 L (i = 7) H (i = 28) TR 65 x 10 (Single start)

n rpm	v mm/min L H		$\eta_d$ L H		200 kN				160 kN				120 kN				100 kN			
					TLP		THP		TLP		THP		TLP		THP		TLP		THP	
					Nm	kW	Nm	kW	Nm	kW	Nm	kW	Nm	kW	Nm	kW	Nm	kW	Nm	kW
1500	2143	536	.35	.23													<b>29</b>	<b>4.5</b>		
1000	1429	357	.33	.22							<b>41</b>	<b>4.3</b>			<b>31</b>	<b>3.2</b>	<b>67</b>	<b>7.0</b>	<b>26</b>	<b>2.7</b>
750	1071	268	.32	.20							<b>44</b>	<b>3.4</b>	<b>84</b>	<b>6.6</b>	33	2.6	<b>70</b>	<b>5.5</b>	28	2.2
500	714	179	.30	.19							48	2.5	<b>90</b>	<b>4.7</b>	36	1.9	<b>75</b>	<b>3.9</b>	30	1.6
300	429	107	.27	.17			66	2.1	<b>131</b>	<b>4.1</b>	53	1.7	<b>98</b>	<b>3.1</b>	40	1.3	82	2.6	34	1.1
250	357	89	.26	.16			69	1.8	<b>135</b>	<b>3.5</b>	55	1.4	102	2.6	42	1.1	85	2.2	35	.91
200	286	71	.25	.15			72	1.5	141	2.9	58	1.2	106	2.2	44	.91	88	1.8	36	.76
150	214	54	.24	.14	184	2.9	76	1.2	147	2.3	61	.96	111	1.7	46	.73	92	1.5	39	.61
125	179	45	.23	.14	190	2.5	79	1.0	152	2.0	64	.80	114	1.5	48	.60	95	1.3	40	.51
100	143	36	.23	.13	197	2.1	83	.87	157	1.7	67	.70	118	1.3	50	.53	99	1.1	42	.44
50	71	18	.20	.12	218	1.1	94	.49	174	.88	76	.39	131	.66	57	.30	109	.55	48	.25

n rpm	v mm/min L H		$\eta_d$ L H		75 kN				50 kN				25 kN			
					TLP		THP		TLP		THP		TLP		THP	
					Nm	kW	Nm	kW	Nm	kW	Nm	kW	Nm	kW	Nm	kW
1500	2143	536	.35	.23	<b>47</b>	<b>7.5</b>	<b>18</b>	<b>2.9</b>	<b>32</b>	<b>5.0</b>	12	2.0	16	2.6	6.7	1.0
1000	1429	357	.33	.22	<b>50</b>	<b>5.3</b>	20	2.1	<b>34</b>	<b>3.5</b>	13	1.4	17	1.8	7.2	.75
750	1071	268	.32	.20	<b>53</b>	<b>4.2</b>	21	1.6	36	2.8	14	1.1	18	1.4	7.6	.59
500	714	179	.30	.19	<b>57</b>	<b>3.0</b>	23	1.2	38	2.0	15	.81	19	1.0	8.2	.43
300	429	107	.27	.17	62	1.9	25	.80	42	1.3	17	.55	21	.66	9.0	.29
250	357	89	.26	.16	64	1.7	26	.69	43	1.1	18	.47	22	.57	9.3	.24
200	286	71	.25	.15	66	1.4	28	.57	44	.92	19	.39	23	.47	9.8	.20
150	214	54	.24	.14	70	1.1	29	.46	47	.74	20	.31	24	.37	10	.16
125	179	45	.23	.14	72	.94	30	.38	48	.63	20	.26	24	.32	11	.13
100	143	36	.23	.13	74	.79	32	.33	50	.53	21	.22	25	.27	11	.12
50	71	18	.20	.12	82	.42	36	.19	55	.28	24	.13	28	.14	13	.07



## POWER RATINGS BD-BDL SINGLE START SPINDLE

### BD 100 L (i = 7) H (i = 28) TR 90 x 12 (Single start)

n rpm	v mm/min L H		$\eta_d$ L H		300 kN				250 kN				200 kN				150 kN				
					TLP		THP		TLP		THP		TLP		THP		TLP		THP		
					Nm	kW	Nm	kW	Nm	kW	Nm	kW	Nm	kW	Nm	kW	Nm	kW	Nm	kW	
1000	1714	429	.32	.21													<b>125</b>	<b>13</b>	<b>49</b>	<b>5.1</b>	
750	1286	321	.31	.19												<b>69</b>	<b>5.4</b>	<b>131</b>	<b>10</b>	<b>52</b>	<b>4.1</b>
500	857	214	.29	.18									<b>187</b>	<b>9.8</b>	<b>75</b>	<b>3.9</b>	<b>141</b>	<b>7.4</b>	56	2.9	
300	514	129	.26	.16									<b>206</b>	<b>6.5</b>	84	2.6	<b>155</b>	<b>4.9</b>	63	2.0	
250	429	107	.25	.15					<b>266</b>	<b>7.0</b>	109	2.9	<b>213</b>	<b>5.6</b>	87	2.3	<b>160</b>	<b>4.2</b>	66	1.8	
200	343	86	.24	.14					<b>277</b>	<b>5.8</b>	115	2.4	<b>222</b>	<b>4.6</b>	92	1.9	166	3.5	69	1.4	
150	257	64	.23	.13	<b>350</b>	<b>5.5</b>			<b>291</b>	<b>4.6</b>	122	1.9	233	3.7	98	1.5	175	2.8	74	1.1	
125	214	54	.22	.13	<b>361</b>	<b>4.7</b>			<b>301</b>	<b>3.9</b>	127	1.7	241	3.1	102	1.4	181	2.4	77	1.0	
100	171	43	.21	.12	<b>375</b>	<b>3.9</b>			313	3.3	133	1.4	250	2.6	107	1.1	188	2.0	80	.84	
50	86	21	.19	.11	420	2.2	183	.96	350	1.8	153	.80	280	1.5	122	.64	210	1.1	92	.48	

n rpm	v mm/min L H		$\eta_d$ L H		100 kN				75 kN				50 kN			
					TLP		THP		TLP		THP		TLP		THP	
					Nm	kW	Nm	kW	Nm	kW	Nm	kW	Nm	kW	Nm	kW
1000	1714	429	.32	.21	<b>84</b>	<b>8.7</b>	<b>33</b>	<b>3.4</b>	<b>63</b>	<b>6.6</b>	25	2.6	<b>42</b>	<b>4.4</b>	17	1.8
750	1286	321	.31	.19	<b>88</b>	<b>6.7</b>	35	2.7	<b>66</b>	<b>5.0</b>	26	2.1	44	3.4	18	1.4
500	857	214	.29	.18	<b>94</b>	<b>4.9</b>	38	2.0	71	3.7	29	1.5	48	2.5	20	1.0
300	514	129	.26	.16	103	3.3	43	1.3	78	2.5	32	1.0	52	1.6	22	.67
250	429	107	.25	.15	107	2.8	44	1.2	80	2.1	33	.89	54	1.4	23	.60
200	343	86	.24	.14	111	2.3	47	.97	84	1.8	35	.74	56	1.2	24	.50
150	257	64	.23	.13	117	1.8	49	.77	88	1.4	37	.58	59	.93	25	.39
125	214	54	.22	.13	121	1.6	51	.69	91	1.2	39	.52	61	.79	26	.35
100	171	43	.21	.12	126	1.3	54	.57	95	.98	41	.43	63	.66	27	.29
50	86	21	.19	.11	141	.74	62	.32	106	.55	47	.24	71	.37	31	.16

### BD 125 L (i = 7.5) H (i = 30) TR 120 x 14 (Single start)

n rpm	v mm/min L H		$\eta_d$ L H		500 kN				400 kN				300 kN				250 kN				
					TLP		THP		TLP		THP		TLP		THP		TLP		THP		
					Nm	kW	Nm	kW	Nm	kW	Nm	kW	Nm	kW	Nm	kW	Nm	kW	Nm	kW	
1000	1867	467	.31	.20																<b>91</b>	<b>9.6</b>
750	1400	350	.29	.19											<b>117</b>	<b>9.2</b>	<b>249</b>	<b>20.0</b>	<b>97</b>	<b>7.7</b>	
500	933	233	.27	.17									<b>321</b>	<b>17</b>	<b>128</b>	<b>6.7</b>	<b>268</b>	<b>14.0</b>	<b>107</b>	<b>5.6</b>	
300	560	140	.25	.15									<b>354</b>	<b>11</b>	144	4.5	<b>295</b>	<b>9.2</b>	120	3.8	
250	467	117	.24	.14									<b>366</b>	<b>9.6</b>	150	3.9	<b>305</b>	<b>8.0</b>	125	3.3	
200	373	93	.23	.14					<b>509</b>	<b>11</b>			<b>382</b>	<b>8.3</b>	158	3.3	<b>318</b>	<b>6.9</b>	131	2.8	
150	280	70	.22	.13					<b>537</b>	<b>8.4</b>	224	3.5	<b>403</b>	<b>6.3</b>	168	2.6	<b>336</b>	<b>5.3</b>	140	2.2	
125	233	58	.21	.12					<b>556</b>	<b>7.3</b>	233	3.1	<b>417</b>	<b>5.5</b>	175	2.3	348	4.6	145	1.9	
100	187	47	.20	.12	<b>723</b>	<b>7.6</b>			<b>579</b>	<b>6.1</b>	244	2.6	435	4.6	184	2.0	362	3.8	153	1.6	
50	93	23	.18	.10	815	4.3			652	3.4	281	1.5	489	2.6	211	1.1	408	2.2	176	.94	

n rpm	v mm/min L H		$\eta_d$ L H		200 kN				150 kN				100 kN			
					TLP		THP		TLP		THP		TLP		THP	
					Nm	kW	Nm	kW	Nm	kW	Nm	kW	Nm	kW	Nm	kW
1000	1867	467	.31	.20	<b>190</b>	<b>20</b>	<b>73</b>	<b>7.7</b>	<b>143</b>	<b>15</b>	<b>55</b>	<b>5.8</b>	<b>96</b>	<b>10</b>	37	3.9
750	1400	350	.29	.19	<b>200</b>	<b>16</b>	<b>78</b>	<b>6.2</b>	<b>150</b>	<b>12</b>	<b>59</b>	<b>4.7</b>	<b>101</b>	<b>8.1</b>	40	3.1
500	933	233	.27	.17	<b>215</b>	<b>11</b>	86	4.5	<b>161</b>	<b>8.5</b>	65	3.4	<b>108</b>	<b>5.7</b>	44	2.3
300	560	140	.25	.15	<b>236</b>	<b>7.3</b>	96	3.0	<b>177</b>	<b>5.5</b>	73	2.3	119	3.7	49	1.5
250	467	117	.24	.14	<b>244</b>	<b>6.4</b>	100	2.6	184	4.8	76	2.0	123	3.2	51	1.3
200	373	93	.23	.14	<b>265</b>	<b>5.5</b>	105	2.2	192	4.1	79	1.7	128	2.8	53	1.1
150	280	70	.22	.13	269	4.2	112	1.8	202	3.2	85	1.3	135	2.1	57	.89
125	233	58	.21	.12	279	3.7	117	1.6	209	2.7	88	1.2	140	1.8	59	.79
100	187	47	.20	.12	290	3.0	123	1.3	218	2.3	92	.98	146	1.5	62	.66
50	93	23	.18	.10	327	1.7	141	.75	245	1.3	106	.57	164	.87	71	.38

## POWER RATINGS BD-BDL SINGLE START SPINDLE

**BD 200 L (i = 12) H (i = 36) TR 160 x 16 (Single start)**

n rpm	v mm/min		η <sub>d</sub>		1000 kN				800 kN				700 kN				600 kN			
	L	H	L	H	TLP Nm	THP kW	TLP Nm	THP kW	TLP Nm	THP kW	TLP Nm	THP kW	TLP Nm	THP kW	TLP Nm	THP kW	TLP Nm	THP kW		
850	1133	378	.26	.18							<b>304</b>	<b>27</b>	<b>561</b>	<b>50</b>	<b>267</b>	<b>24</b>	<b>481</b>	<b>43</b>	<b>229</b>	<b>20</b>
750	1000	333	.25	.18							<b>313</b>	<b>25</b>	<b>574</b>	<b>45</b>	<b>274</b>	<b>22</b>	<b>493</b>	<b>39</b>	<b>255</b>	<b>19</b>
500	667	222	.23	.16					<b>708</b>	<b>37</b>	<b>342</b>	<b>18</b>	<b>620</b>	<b>32</b>	<b>300</b>	<b>16</b>	<b>532</b>	<b>28</b>	<b>258</b>	<b>14</b>
300	400	133	.21	.14	<b>978</b>	<b>31</b>	<b>480</b>	<b>15</b>	<b>783</b>	<b>25</b>	384	12	<b>686</b>	<b>22</b>	337	11	<b>588</b>	<b>19</b>	289	9.0
250	333	111	.20	.14	<b>1014</b>	<b>27</b>	<b>500</b>	<b>13</b>	<b>812</b>	<b>22</b>	400	10	<b>711</b>	<b>19</b>	351	9.1	<b>610</b>	<b>16</b>	301	7.8
200	267	89	.20	.13	<b>1060</b>	<b>22</b>	525	11	<b>848</b>	<b>18</b>	421	8.8	<b>743</b>	<b>15</b>	368	7.7	<b>637</b>	<b>13</b>	316	6.6
150	200	67	.18	.12	<b>1121</b>	<b>18</b>	560	8.8	<b>897</b>	<b>14</b>	448	7.0	<b>785</b>	<b>13</b>	393	6.2	674	11	337	5.3
100	133	44	.17	.11	<b>1210</b>	<b>13</b>	611	6.4	969	10	489	5.1	848	9.1	428	4.5	727	7.8	368	3.9
50	67	22	.15	.10	1368	7.2	704	3.7	1095	5.8	563	3.0	958	5.0	493	2.6	822	4.3	423	2.2

n rpm	v mm/min		η <sub>d</sub>		500 kN				400 kN				300 kN				200 kN			
	L	H	L	H	TLP Nm	THP kW	TLP Nm	THP kW	TLP Nm	THP kW	TLP Nm	THP kW	TLP Nm	THP kW	TLP Nm	THP kW	TLP Nm	THP kW		
850	1133	378	.26	.18	<b>402</b>	<b>36</b>	<b>191</b>	<b>17</b>	<b>322</b>	<b>29</b>	<b>154</b>	<b>14</b>	<b>242</b>	<b>22</b>	116	10	<b>163</b>	<b>14</b>	78	7.0
750	1000	333	.25	.18	<b>411</b>	<b>32</b>	<b>197</b>	<b>16</b>	<b>329</b>	<b>26</b>	<b>158</b>	<b>13</b>	<b>248</b>	<b>19</b>	119	9.5	<b>166</b>	<b>13</b>	80	6.4
500	667	222	.23	.16	<b>444</b>	<b>23</b>	215	11	<b>356</b>	<b>19</b>	173	9.1	<b>268</b>	<b>14</b>	130	6.9	179	9.4	88	4.6
300	400	133	.21	.14	<b>491</b>	<b>16</b>	241	7.5	393	12	194	6.1	296	9.4	146	4.6	198	6.3	98	3.1
250	333	111	.20	.14	<b>508</b>	<b>14</b>	251	6.5	407	11	202	5.2	306	8.2	152	4.0	205	5.5	102	2.7
200	267	89	.20	.13	531	11	264	5.5	426	8.8	212	4.4	320	6.6	160	3.3	214	4.5	107	2.3
150	200	67	.18	.12	562	9.0	281	4.4	450	7.2	226	3.5	338	5.4	170	2.7	227	3.6	114	1.8
100	133	44	.17	.11	607	6.5	307	3.2	486	5.2	246	2.6	365	3.9	185	1.9	245	2.6	125	1.3
50	67	22	.15	.10	685	3.6	353	1.9	549	2.9	283	1.5	412	2.2	213	1.1	276	1.5	143	.75

## POWER RATINGS BD-BDL DOUBLE START SPINDLE

Power ratings for BD-BDL with double start spindle at 40% ED/10 min or max 20% ED/hour at ambient temperature +25° C.

n = input speed (rpm)  
 v = lifting speed (mm/min)  
 η<sub>d</sub> = running efficiency  
 L = low ratio  
 H = high ratio  
 T = input torque (Nm)  
 P = input power (kW)  
 i = ratio of worm gear set

### Mechanical and Thermal capacities:

- A) Mechanical capacity: all stated values non blank areas in tables.
- B) Mechanical capacity with stainless worm screw: Grey areas in tables
- C) Thermal capacity:  
 The figures above the line in **Italics** can only be used at ED lower than 20%. Thermal power must be checked. See "Intermittence factor (ED) BD/BDL".

**Note:** Power ratings indicate running power. Additional power will be required on start. See "Selection of jacks" on page 10.

## POWER RATINGS BD-BDL DOUBLE START SPINDLE

### BD 27 L (i = 9) H (i = 27) TR 20 x 8 (Double start)

n rpm	v mm/min		$\eta_d$		8 kN				6 kN				4 kN				2 kN			
					TLP		THP		TLP		THP		TLP		THP		TLP		THP	
					Nm	kW	Nm	kW	Nm	kW	Nm	kW	Nm	kW	Nm	kW	Nm	kW	Nm	kW
2900	2578	859	.41	.26			<b>1.4</b>	<b>.43</b>	<b>2.0</b>	<b>.61</b>	<b>1.1</b>	<b>.34</b>	<b>1.4</b>	<b>.43</b>	<b>.82</b>	<b>.25</b>	.83	.25	.53	.16
1750	1556	519	.40	.24	<b>2.8</b>	<b>.51</b>	<b>1.5</b>	<b>.28</b>	<b>2.2</b>	<b>.39</b>	<b>1.2</b>	<b>.22</b>	<b>1.5</b>	<b>.28</b>	<b>.87</b>	<b>.16</b>	.88	.16	.56	.10
1500	1333	444	.39	.23	<b>2.8</b>	<b>.45</b>	<b>1.6</b>	<b>.25</b>	<b>2.2</b>	<b>.35</b>	<b>1.3</b>	<b>.20</b>	<b>1.5</b>	<b>.24</b>	<b>.92</b>	<b>.14</b>	.88	.14	.58	.09
1000	889	296	.37	.22	<b>3.0</b>	<b>.31</b>	<b>1.7</b>	<b>.18</b>	<b>2.3</b>	<b>.24</b>	<b>1.3</b>	<b>.14</b>	<b>1.6</b>	<b>.17</b>	<b>.97</b>	<b>.10</b>	.93	.10	.61	.06
750	667	222	.36	.21	3.1	.25	1.8	.14	2.4	.19	1.4	.11	1.7	.13	1.0	0.8	.96	.08	.63	.05
500	444	148	.34	.19	3.3	.17	1.9	.10	2.5	.13	1.5	.08	1.8	.09	1.1	0.6	1.0	.05	.66	.05
400	356	119	.33	.18	3.4	.14	2.0	.08	2.6	.11	1.6	.06	1.8	.08	1.1	.05	1.0	.05	.68	.05
300	267	89	.31	.17	3.6	.11			2.8	.08	1.6	.05	1.9	.06	1.2	.05	1.1	.05	.71	.05
200	178	59	.30	.16	3.8	.08			2.9	.06	1.8	.05	2.0	.05	1.3	.05	1.1	.05	.76	.05
100	89	30	.27	.14					3.1	.05	2.0	.05	2.2	.05	1.4	.05	1.2	.05	.83	.05
50	44	15	.25	.12					3.4	.05	2.3	.05	2.3	.05	1.6	.05	1.3	.05	.93	.05

n rpm	v mm/min		$\eta_d$		1 kN			
					TLP		THP	
					Nm	kW	Nm	kW
2900	2578	859	.41	.26	.53	.16	.39	.12
1750	1556	519	.40	.24	.56	.10	.40	.07
1500	1333	444	.39	.23	.56	.09	.41	.06
1000	889	296	.37	.22	.59	.06	.42	.05
750	667	222	.36	.21	.60	.05	.44	.05
500	444	148	.34	.19	.62	.05	.45	.05
400	356	119	.33	.18	.64	.05	.46	.05
300	267	89	.31	.17	.66	.05	.47	.05
200	178	59	.30	.16	.69	.05	.50	.05
100	89	30	.27	.14	.72	.05	.54	.05
50	44	15	.25	.12	.76	.05	.59	.05

### BD 40 L (i = 7) H (i = 30) TR 30 x 12 (Double start)

n rpm	v mm/min		$\eta_d$		20 kN				15 kN				10 kN				7.5 kN			
					TLP		THP		TLP		THP		TLP		THP		TLP		THP	
					Nm	kW	Nm	kW	Nm	kW	Nm	kW	Nm	kW	Nm	kW	Nm	kW	Nm	kW
2600	4457	1040	.51	.34	<b>11</b>	<b>2.9</b>	<b>3.7</b>	<b>1.0</b>	<b>8.1</b>	<b>2.2</b>	<b>2.9</b>	<b>.77</b>	<b>5.5</b>	<b>1.5</b>	2.0	.55	<b>4.2</b>	<b>1.1</b>	1.6	.43
1750	3000	700	.48	.32	<b>11</b>	<b>2.0</b>	<b>3.9</b>	<b>.72</b>	<b>8.4</b>	<b>1.5</b>	<b>3.0</b>	<b>.56</b>	<b>5.7</b>	<b>1.0</b>	2.1	.39	<b>4.4</b>	<b>.79</b>	1.7	.31
1500	2571	600	.48	.31	<b>11</b>	<b>1.8</b>	<b>4.0</b>	<b>.63</b>	<b>8.6</b>	<b>1.4</b>	3.1	.49	<b>5.9</b>	<b>.93</b>	2.2	.34	<b>4.5</b>	<b>.71</b>	1.7	.27
1000	1714	400	.45	.29	<b>12</b>	<b>1.3</b>	4.3	.45	<b>9.0</b>	<b>.98</b>	3.3	.35	6.1	.67	2.3	.24	4.7	.51	1.8	.19
750	1286	300	.44	.28	<b>12</b>	<b>.97</b>	4.5	.35	<b>9.4</b>	<b>.73</b>	3.5	.27	6.4	.50	2.4	.19	4.9	.38	1.9	.15
500	857	200	.41	.26	13	.68	4.8	.25	9.9	.51	3.7	.19	6.7	.35	2.6	.13	5.1	.27	2.0	.11
400	686	160	.40	.25	14	.56	5.0	.21	10	.42	3.8	.16	6.9	.29	2.7	.11	5.3	.22	2.1	.09
300	514	120	.38	.24	14	.44	5.2	.16	11	.33	4.0	.12	7.2	.23	2.8	.09	5.5	.17	2.2	.07
200	343	80	.36	.22	15	.31	5.6	.12	11	.23	4.3	.09	7.6	.16	3.0	.06	5.8	.12	2.3	.05
100	171	40	.33	.20	16	.17	6.3	.07	12	.13	4.8	.05	8.2	.09	3.3	.05	6.3	.07	2.6	.05
50	86	20	.31	.18	17	.09	6.9	.05	13	.07	5.3	.05	8.9	.05	3.6	.05	6.7	.05	2.8	.05

n rpm	v mm/min		$\eta_d$		5 kN				2.5 kN			
					TLP		THP		TLP		THP	
					Nm	kW	Nm	kW	Nm	kW	Nm	kW
2600	4457	1040	.51	.34	<b>2.9</b>	<b>.80</b>	1.2	.32	1.6	.44	.76	.21
1750	3000	700	.48	.32	3.0	.55	1.2	.23	1.7	.31	.79	.15
1500	2571	600	.48	.31	3.1	.49	1.3	.20	1.7	.27	.80	.13
1000	1714	400	.45	.29	3.2	.35	1.3	.14	1.8	.19	.84	.09
750	1286	300	.44	.28	3.4	.26	1.4	.11	1.9	.14	.86	.07
500	857	200	.41	.26	3.5	.18	1.5	.08	1.9	.10	.90	.05
400	686	160	.40	.25	3.6	.15	1.5	.06	2.0	.08	.93	.05
300	514	120	.38	.24	3.8	.12	1.6	.05	2.1	.06	.95	.05
200	343	80	.36	.22	4.0	.08	1.7	.05	2.2	.05	1.0	.05
100	171	40	.33	.20	4.3	.05	1.8	.05	2.3	.05	1.1	.05
50	86	20	.31	.18	4.6	.05	2.0	.05	2.5	.05	1.2	.05

# SERIES BD

## POWER RATINGS BD-BDL DOUBLE START SPINDLE

### BD 58 L (i = 6.75) H (i = 27) TR 40 x 14 (Double start)

n rpm	v mm/min		$\eta_d$		40 kN				30 kN				25 kN				20 kN			
					TLP		THP		TLP		THP		TLP		THP		TLP		THP	
					Nm	kW	Nm	kW	Nm	kW	Nm	kW	Nm	kW	Nm	kW	Nm	kW	Nm	kW
2000	4148	1037	.50	.33	<b>26</b>	<b>5.5</b>	<b>9.8</b>	<b>2.1</b>	<b>20</b>	<b>4.2</b>	<b>7.5</b>	<b>1.6</b>	<b>17</b>	<b>3.5</b>	<b>6.3</b>	<b>1.4</b>	<b>13</b>	<b>2.8</b>	<b>5.2</b>	<b>1.1</b>
1750	3630	907	.49	.32	<b>27</b>	<b>4.9</b>	<b>10</b>	<b>1.8</b>	<b>20</b>	<b>3.7</b>	<b>7.7</b>	<b>1.4</b>	<b>17</b>	<b>3.1</b>	<b>6.5</b>	<b>1.2</b>	<b>14</b>	<b>2.5</b>	5.3	.95
1500	3111	778	.48	.31	<b>27</b>	<b>4.2</b>	<b>10</b>	<b>1.6</b>	<b>20</b>	<b>3.2</b>	<b>7.9</b>	<b>1.2</b>	<b>17</b>	<b>2.7</b>	6.6	1.0	<b>14</b>	<b>2.1</b>	5.4	.84
1000	2074	519	.46	.29	<b>28</b>	<b>3.0</b>	<b>11</b>	<b>1.2</b>	<b>21</b>	<b>2.3</b>	8.5	.91	<b>18</b>	<b>1.9</b>	7.1	.77	<b>14</b>	<b>1.5</b>	5.8	.63
750	1556	389	.44	.28	<b>29</b>	<b>2.3</b>	12	.92	<b>22</b>	<b>1.7</b>	8.9	.70	<b>19</b>	<b>1.5</b>	7.5	.59	<b>15</b>	<b>1.2</b>	6.1	.48
500	1037	259	.42	.26	<b>31</b>	<b>1.6</b>	13	.66	<b>23</b>	<b>1.2</b>	9.6	.50	20	1.0	8.1	.42	16	.81	6.6	.34
400	830	207	.41	.25	<b>32</b>	<b>1.3</b>	13	.55	24	.98	10	.42	20	.82	8.4	.35	16	.66	6.8	.29
300	622	156	.39	.23	33	1.0	14	.44	25	.75	11	.33	21	.63	8.9	.28	17	.51	7.2	.23
200	415	104	.37	.21	35	.74	15	.31	26	.56	11	.24	22	.47	9.6	.20	18	.38	7.8	.16
100	207	52	.34	.19	38	.40	17	.18	29	.30	13	.14	24	.25	11	.11	19	.20	8.8	.09
50	104	26	.31	.17	42	.22	19	.10	31	.17	15	.08	26	.14	12	.06	21	.11	10	.05

n rpm	v mm/min		$\eta_d$		15 kN				10 kN			
					TLP		THP		TLP		THP	
					Nm	kW	Nm	kW	Nm	kW	Nm	kW
2000	4148	1037	.50	.33	<b>10</b>	<b>2.1</b>	4.0	.86	<b>6.9</b>	<b>1.5</b>	2.8	.61
1750	3630	907	.49	.32	<b>10</b>	<b>1.9</b>	4.1	.73	<b>7.0</b>	<b>1.3</b>	2.9	.52
1500	3111	778	.48	.31	<b>10</b>	<b>1.6</b>	4.2	.65	7.1	1.1	3.0	.46
1000	2074	519	.46	.29	<b>11</b>	<b>1.2</b>	4.5	.48	7.5	.79	3.2	.34
750	1556	389	.44	.28	11	.89	4.7	.37	7.7	.61	3.3	.26
500	1037	259	.42	.26	12	.62	5.0	.26	8.1	.42	3.5	.19
400	830	207	.41	.25	12	.50	5.2	.22	8.4	.34	3.7	.15
300	622	156	.39	.23	13	.39	5.5	.18	8.7	.26	3.9	.12
200	415	104	.37	.21	13	.28	5.9	.12	9.2	.19	4.1	.09
100	207	52	.34	.19	15	.15	6.7	.07	10	.10	4.7	.05
50	104	26	.31	.17	16	.08	7.6	.05	11	.06	5.2	.05

### BD 66 L (i = 7) H (i = 28) TR 55 x 18 (Double start)

n rpm	v mm/min		$\eta_d$		120 kN				100 kN				75 kN				50 kN			
					TLP		THP		TLP		THP		TLP		THP		TLP		THP	
					Nm	kW	Nm	kW	Nm	kW	Nm	kW	Nm	kW	Nm	kW	Nm	kW	Nm	kW
1750	4500	1125	.50	.33													<b>41</b>	<b>7.5</b>	<b>15</b>	<b>2.8</b>
1500	3857	964	.49	.33													<b>41</b>	<b>6.5</b>	<b>16</b>	<b>2.4</b>
1000	2571	643	.47	.30													<b>43</b>	<b>4.6</b>	<b>17</b>	<b>1.7</b>
750	1929	482	.45	.29									<b>67</b>	<b>5.3</b>			<b>45</b>	<b>3.5</b>	18	1.4
500	1286	321	.43	.27									<b>71</b>	<b>3.7</b>	28	1.5	<b>48</b>	<b>2.5</b>	19	1.0
300	771	193	.40	.24									<b>76</b>	<b>2.4</b>	31	.98	51	1.6	21	.66
250	643	161	.39	.23					<b>104</b>	<b>2.7</b>			<b>78</b>	<b>2.0</b>	32	.84	52	1.4	22	.57
200	514	129	.38	.22					<b>108</b>	<b>2.3</b>			81	1.7	34	.70	54	1.2	23	.47
150	386	96	.36	.21					112	1.8			84	1.4	36	.56	56	.90	24	.38
125	321	80	.35	.20					115	1.5	49	.64	86	1.1	37	.48	58	.75	25	.32
100	257	64	.34	.20	142	1.5			118	1.3	51	.53	89	.94	38	.40	59	.63	26	.27
50	129	32	.31	.17	154	.81	69	.36	129	.68	58	.30	97	.51	43	.23	65	.34	29	.15

n rpm	v mm/min		$\eta_d$		25 kN				20 kN				10 kN			
					TLP		THP		TLP		THP		TLP		THP	
					Nm	kW	Nm	kW	Nm	kW	Nm	kW	Nm	kW	Nm	kW
1750	4500	1125	.50	.33	<b>21</b>	<b>3.8</b>	7.9	1.5	<b>17</b>	<b>3.1</b>	6.4	1.2	8.6	1.6	3.5	.65
1500	3857	964	.49	.33	<b>21</b>	<b>3.3</b>	8.1	1.2	<b>17</b>	<b>2.7</b>	6.6	1.0	8.8	1.4	3.6	.56
1000	2571	643	.47	.30	<b>22</b>	<b>2.3</b>	8.6	.88	18	1.9	7.0	.72	9.2	.97	3.8	.39
750	1929	482	.45	.29	23	1.8	9.1	.72	18	1.4	7.4	.59	9.5	.75	4.0	.32
500	1286	321	.43	.27	24	1.3	9.8	.52	19	1.0	7.9	.42	10	.52	4.3	.23
300	771	193	.40	.24	26	.81	11	.34	21	.65	8.7	.28	11	.34	4.7	.15
250	643	161	.39	.23	27	.69	11	.29	21	.55	9.0	.24	11	.28	4.8	.13
200	514	129	.38	.22	27	.58	12	.24	22	.47	9.4	.20	11	.24	5.0	.10
150	386	96	.36	.21	28	.46	12	.19	23	.37	9.9	.16	12	.19	5.3	.08
125	321	80	.35	.20	29	.38	13	.17	23	.31	10	.13	12	.16	5.4	.07
100	257	64	.34	.20	30	.32	13	.14	24	.26	11	.11	12	.13	5.7	.06
50	129	32	.31	.17	33	.17	15	.08	26	.14	12	.06	13	.07	6.3	.05

## POWER RATINGS BD-BDL DOUBLE START SPINDLE

### BD 86 L (i = 7) H (i = 28) TR 65 x 20 (Double start)

n rpm	v mm/min		$\eta_d$		160 kN				120 kN				100 kN				75 kN			
					TLP		THP		TLP		THP		TLP		THP		TLP		THP	
					Nm	kW	Nm	kW	Nm	kW	Nm	kW	Nm	kW	Nm	kW	Nm	kW	Nm	kW
1500	4286	1071	.49	.34									<b>91</b>	<b>14</b>	<b>33</b>	<b>5.2</b>	<b>69</b>	<b>11</b>	<b>25</b>	<b>3.9</b>
1000	2857	714	.47	.32					<b>114</b>	<b>12</b>	<b>42</b>	<b>4.4</b>	<b>96</b>	<b>10</b>	<b>35</b>	<b>3.7</b>	<b>72</b>	<b>7.5</b>	27	2.8
750	2143	536	.45	.30					<b>119</b>	<b>9.3</b>	<b>44</b>	<b>3.5</b>	<b>99</b>	<b>7.8</b>	<b>37</b>	<b>2.9</b>	<b>75</b>	<b>5.8</b>	28	2.2
500	1429	357	.43	.28					<b>125</b>	<b>6.6</b>	48	2.5	<b>105</b>	<b>5.5</b>	40	2.1	<b>79</b>	<b>4.1</b>	30	1.6
300	857	214	.40	.26	<b>179</b>	<b>5.6</b>	70	2.2	<b>135</b>	<b>4.2</b>	53	1.7	112	3.5	44	1.4	84	2.6	33	1.0
250	714	179	.39	.25	<b>184</b>	<b>4.8</b>	72	1.9	138	3.6	54	1.4	115	3.0	46	1.2	87	2.3	34	.90
200	571	143	.38	.24	<b>190</b>	<b>4.0</b>	75	1.6	142	3.0	57	1.2	119	2.5	48	1.0	89	1.9	36	.76
150	429	107	.36	.22	197	3.1	80	1.3	148	2.3	60	.98	124	1.9	50	.82	93	1.5	38	.62
125	357	89	.35	.22	202	2.7	82	1.1	152	2.0	62	.83	127	1.7	52	.69	95	1.3	39	.52
100	286	71	.34	.21	209	2.2	86	.90	157	1.7	65	.68	131	1.4	54	.57	98	1.0	41	.43
50	143	36	.31	.18	228	1.2	97	.51	171	.90	73	.38	143	.75	61	.32	107	.56	46	.24

n rpm	v mm/min		$\eta_d$		50 kN				25 kN			
					TLP		THP		TLP		THP	
					Nm	kW	Nm	kW	Nm	kW	Nm	kW
1500	4286	1071	.49	.34	<b>46</b>	<b>7.1</b>	17	2.7	23	3.6	8.8	1.4
1000	2857	714	.47	.32	<b>48</b>	<b>5.1</b>	18	1.9	25	2.6	9.4	.99
750	2143	536	.45	.30	<b>50</b>	<b>3.9</b>	19	1.5	25	2.0	9.9	.78
500	1429	357	.43	.28	53	2.8	20	1.1	27	1.4	11	.56
300	857	214	.40	.26	57	1.8	22	.71	29	.90	12	.37
250	714	179	.39	.25	58	1.5	23	.61	29	.77	12	.32
200	571	143	.38	.24	60	1.3	24	.51	30	.64	13	.27
150	429	107	.36	.22	62	.98	25	.42	32	.50	13	.21
125	357	89	.35	.22	64	.85	26	.35	32	.43	14	.18
100	286	71	.34	.21	66	.69	27	.29	33	.35	14	.15
50	143	36	.31	.18	72	.38	31	.16	36	.19	16	.08

### BD 100 L (i = 7) H (i = 28) TR 90 x 24 (Double start)

n rpm	v mm/min		$\eta_d$		240 kN				200 kN				150 kN				100 kN					
					TLP		THP		TLP		THP		TLP		THP		TLP		THP			
					Nm	kW	Nm	kW	Nm	kW	Nm	kW	Nm	kW	Nm	kW	Nm	kW	Nm	kW		
1000	3429	857	.46	.31															<b>118</b>	<b>12</b>	<b>43</b>	<b>4.6</b>
750	2571	643	.44	.30									<b>183</b>	<b>14</b>	<b>68</b>	<b>5.4</b>	<b>122</b>	<b>9.4</b>	<b>46</b>	<b>3.6</b>		
500	1714	429	.42	.27									<b>193</b>	<b>10</b>	<b>74</b>	<b>3.9</b>	<b>129</b>	<b>6.7</b>	<b>49</b>	<b>2.6</b>		
300	1029	257	.39	.25					<b>277</b>	<b>8.7</b>			<b>208</b>	<b>6.5</b>	82	2.6	139	4.4	55	1.7		
250	857	214	.38	.24					<b>285</b>	<b>7.5</b>			<b>214</b>	<b>5.6</b>	85	2.2	143	3.8	57	1.5		
200	686	171	.37	.23					<b>294</b>	<b>6.2</b>	118	2.5	221	4.7	89	1.9	148	3.1	59	1.3		
150	514	129	.35	.21	<b>369</b>	<b>5.8</b>			<b>307</b>	<b>4.8</b>	125	2.0	231	3.6	94	1.5	154	2.4	63	1.0		
125	429	107	.34	.21	<b>379</b>	<b>5.0</b>			316	4.2	129	1.7	237	3.1	97	1.3	158	2.1	65	.86		
100	343	86	.33	.20	391	4.1			326	3.4	135	1.4	245	2.6	102	1.1	164	1.7	68	.71		
50	171	43	.30	.17	431	2.3	184	.96	359	1.9	154	.80	270	1.4	115	.60	180	.96	77	.40		

n rpm	v mm/min		$\eta_d$		75 kN				50 kN			
					TLP		THP		TLP		THP	
					Nm	kW	Nm	kW	Nm	kW	Nm	kW
1000	3429	857	.46	.31	<b>89</b>	<b>9.0</b>	33	3.5	<b>59</b>	<b>6.1</b>	22	2.4
750	2571	643	.44	.30	<b>92</b>	<b>7.0</b>	35	2.7	62	4.7	23	1.9
500	1714	429	.42	.27	<b>97</b>	<b>5.0</b>	37	2.0	65	3.4	25	1.3
300	1029	257	.39	.25	105	3.3	41	1.3	70	2.2	28	8.9
250	857	214	.38	.24	107	2.8	43	1.1	72	1.9	29	.75
200	686	171	.37	.23	111	2.3	45	.95	74	1.6	30	.64
150	514	129	.35	.21	116	1.8	47	.76	78	1.2	32	.51
125	429	107	.34	.21	119	1.6	49	.65	80	1.1	33	.44
100	343	86	.33	.20	123	1.3	51	.53	82	.86	35	.36
50	171	43	.30	.17	135	.72	58	.30	91	.48	39	.20

# SERIES BD

## POWER RATINGS BD-BDL DOUBLE START SPINDLE

### BD 125 L (i = 7.5) H (i = 30) TR 120 x 28 (Double start)

n rpm	v mm/min		η <sub>d</sub>		400 kN				300 kN				250 kN				200 kN			
	L	H	L	H	TLP Nm	THP kW	TLP Nm	THP kW	TLP Nm	THP kW	TLP Nm	THP kW	TLP Nm	THP kW	TLP Nm	THP kW	TLP Nm	THP kW		
1000	3733	933	.45	.30												<b>264</b>	<b>28</b>	<b>96</b>	<b>10</b>	
750	2800	700	.43	.29									<b>342</b>	<b>27</b>		<b>274</b>	<b>22</b>	<b>102</b>	<b>8.0</b>	
500	1867	467	.41	.27									<b>362</b>	<b>19</b>	<b>137</b>	<b>7.2</b>	<b>290</b>	<b>15</b>	<b>110</b>	<b>5.8</b>
300	1120	280	.38	.24					<b>469</b>	<b>15</b>			<b>391</b>	<b>13</b>	152	4.8	<b>313</b>	<b>10</b>	122	3.8
250	933	233	.36	.23					<b>482</b>	<b>13</b>			<b>402</b>	<b>11</b>	158	4.1	<b>322</b>	<b>8.7</b>	127	3.3
200	747	187	.35	.22					<b>499</b>	<b>11</b>	198	4.2	<b>416</b>	<b>9.2</b>	165	3.5	<b>333</b>	<b>7.3</b>	133	2.8
150	560	140	.34	.21					<b>522</b>	<b>8.2</b>	210	3.3	<b>436</b>	<b>6.8</b>	175	2.8	349	5.5	141	2.2
125	467	117	.33	.20					<b>538</b>	<b>7.0</b>	218	2.8	448	5.8	182	2.3	359	4.7	146	1.9
100	373	93	.32	.19	<b>741</b>	<b>7.8</b>			556	5.9	228	2.4	464	4.9	190	2.0	371	3.9	153	1.6
50	187	47	.28	.17	821	4.3			616	3.2	261	1.4	514	2.7	216	1.2	411	2.2	174	.94

n rpm	v mm/min		η <sub>d</sub>		150 kN				100 kN			
	L	H	L	H	TLP Nm	THP kW	TLP Nm	THP kW	TLP Nm	THP kW	TLP Nm	THP kW
1000	3733	933	.45	.30	<b>198</b>	<b>21</b>	<b>73</b>	<b>7.5</b>	<b>133</b>	<b>14</b>	50	5.1
750	2800	700	.43	.29	<b>206</b>	<b>16</b>	<b>77</b>	<b>6.0</b>	<b>138</b>	<b>11</b>	52	4.1
500	1867	467	.41	.27	<b>218</b>	<b>11</b>	83	4.4	<b>146</b>	<b>7.6</b>	56	2.9
300	1120	280	.38	.24	<b>235</b>	<b>7.5</b>	92	2.9	157	5.0	62	1.9
250	933	233	.36	.23	<b>242</b>	<b>6.5</b>	95	2.5	162	4.4	64	1.7
200	747	187	.35	.22	250	5.5	100	2.1	167	3.7	67	1.4
150	560	140	.34	.21	262	4.1	106	1.7	175	2.7	71	1.1
125	467	117	.33	.20	270	3.5	110	1.4	180	2.3	74	.95
100	373	93	.32	.19	279	2.9	115	1.2	186	2.0	77	.81
50	187	47	.28	.17	309	1.6	131	.70	206	1.1	88	.47

### BD 200 L (i = 12) H (i = 36) TR 160 x 32 (Double start)

n rpm	v mm/min		η <sub>d</sub>		800 kN				700 kN				600 kN				500 kN			
	L	H	L	H	TLP Nm	THP kW	TLP Nm	THP kW	TLP Nm	THP kW	TLP Nm	THP kW	TLP Nm	THP kW	TLP Nm	THP kW	TLP Nm	THP kW		
850	2267	756	.39	.29					<b>748</b>	<b>67</b>			<b>641</b>	<b>57</b>	<b>293</b>	<b>26</b>	<b>535</b>	<b>48</b>	<b>244</b>	<b>22</b>
750	2000	667	.39	.28					<b>761</b>	<b>60</b>			<b>653</b>	<b>51</b>	<b>300</b>	<b>24</b>	<b>545</b>	<b>43</b>	<b>250</b>	<b>20</b>
500	1333	444	.36	.26	<b>925</b>	<b>49</b>			<b>810</b>	<b>43</b>	<b>378</b>	<b>20</b>	<b>695</b>	<b>37</b>	<b>324</b>	<b>17</b>	<b>579</b>	<b>31</b>	271	14
300	800	267	.33	.23	<b>1005</b>	<b>32</b>	477	15	<b>880</b>	<b>28</b>	418	13	<b>754</b>	<b>24</b>	359	11	<b>629</b>	<b>20</b>	299	9.4
250	667	222	.32	.22	<b>1036</b>	<b>27</b>	495	13	<b>906</b>	<b>24</b>	434	11	<b>777</b>	<b>20</b>	372	9.8	<b>648</b>	<b>17</b>	311	8.2
200	533	178	.31	.21	<b>1075</b>	<b>23</b>	518	11	<b>941</b>	<b>20</b>	454	9.6	<b>807</b>	<b>17</b>	389	8.3	673	14	325	6.9
150	400	133	.30	.20	<b>1127</b>	<b>18</b>	549	8.6	987	16	481	7.5	846	14	412	6.5	706	11	344	5.4
125	333	111	.29	.19	1162	15	569	7.5	1017	13	498	6.6	872	11	428	5.6	727	9.4	357	4.7
100	267	89	.28	.19	1204	13	595	6.2	1054	11	521	5.4	904	9.8	447	4.7	754	8.1	373	3.9
50	133	44	.25	.16	1341	7.0	679	3.6	1174	6.1	595	3.2	1007	5.3	510	2.7	839	4.4	426	2.3

n rpm	v mm/min		η <sub>d</sub>		400 kN				300 kN				200 kN			
	L	H	L	H	TLP Nm	THP kW	TLP Nm	THP kW	TLP Nm	THP kW	TLP Nm	THP kW	TLP Nm	THP kW	TLP Nm	THP kW
850	2267	756	.39	.29	<b>429</b>	<b>38</b>	<b>196</b>	<b>17</b>	<b>322</b>	<b>29</b>	148	13	<b>216</b>	<b>19</b>	100	8.9
750	2000	667	.39	.28	<b>436</b>	<b>34</b>	<b>201</b>	<b>16</b>	<b>328</b>	<b>26</b>	151	12	<b>220</b>	<b>17</b>	102	8.2
500	1333	444	.36	.26	<b>464</b>	<b>25</b>	217	11	<b>349</b>	<b>18</b>	164	8.7	234	12	110	5.8
300	800	267	.33	.23	504	16	240	7.5	379	12	181	5.7	254	8.1	122	3.8
250	667	222	.32	.22	519	14	249	6.5	390	10	188	4.9	261	6.8	126	3.3
200	533	178	.31	.21	539	12	260	5.5	405	8.7	196	4.2	271	5.8	132	2.8
150	400	133	.30	.20	565	9.0	276	4.3	425	6.8	208	3.3	284	4.5	140	2.2
125	333	111	.29	.19	582	7.5	286	3.8	437	5.7	215	2.8	293	3.8	145	1.9
100	267	89	.28	.19	604	6.5	299	3.1	454	4.9	225	2.3	303	3.3	151	1.6
50	133	44	.25	.16	672	3.5	341	1.8	505	2.6	257	1.4	338	1.8	172	.91

# SERIES BD

## INTERMITTENCE FACTOR (ED) BD/BDL

Intermittence (ED%) is the percentage of time in which the screw jack is running.

If the intermittence (ED%) is other than 20%, i.e. the jack is running more than 12 minutes per hour (12/60=20%), the Running power ( $P_d$ ) must be adjusted accordingly. Please note  $P_d < P_{ED}$ ; Running power ( $P_d$ ) must be lower than the Thermal power ( $P_{ED}$ ).

$P_{ED}$  [kW] = ED x  $P_{max}$  [kW];  $P_{max}$  is taken from the table below

The intermittence factor ED can be read from the chart or calculated as:

$$\text{Intermittence Factor (ED)} = \frac{20}{\text{ED\%}}$$

ED% = Intermittence per hour

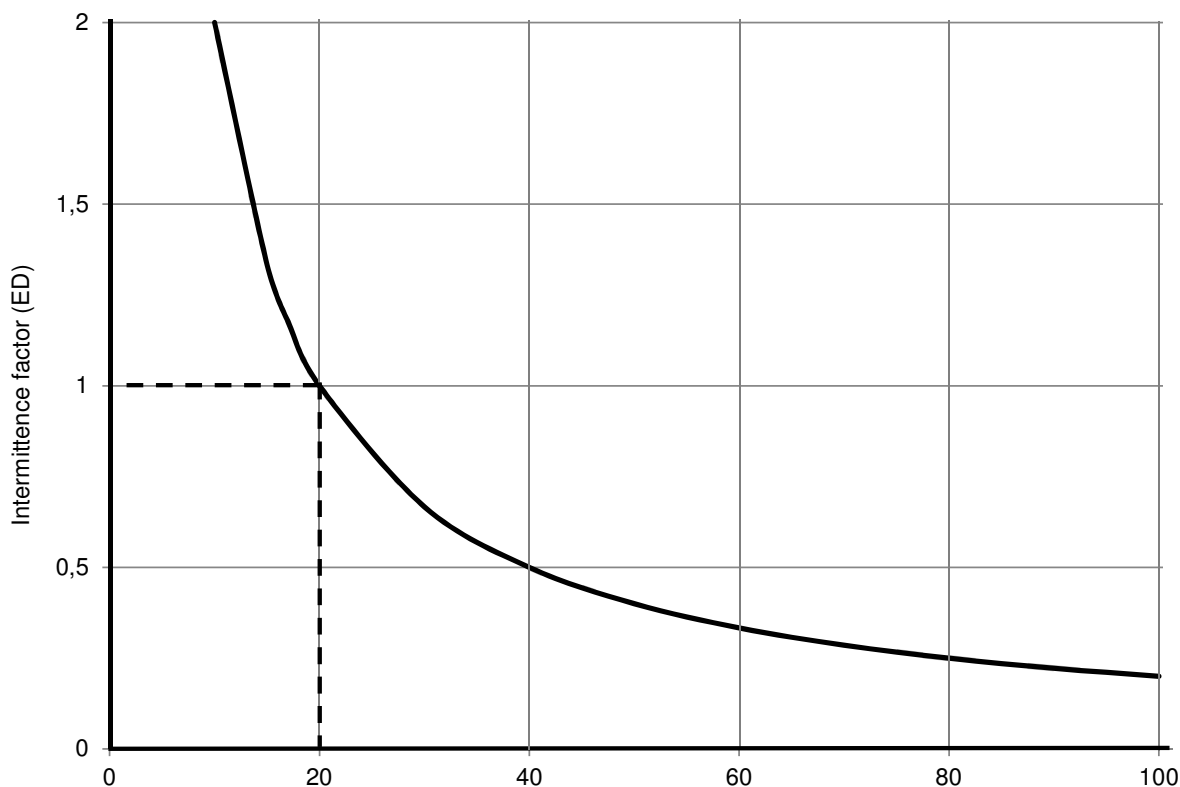

Fig. 22 Intermittence (ED%) per hour

### Thermal rating at 20% ED (1-start spindle)

Size BD-BDL		27	40	58	66	86	100	125	200
$P_{max}$ kW	L	0.2	0.55	0.9	1.5	2.9	3.7	5.1	12.5
	H	0.15	0.5	0.8	1.3	2.6	3.3	4.5	12.0

### Thermal rating at 20% ED (2-start spindle)

Size BD-BDL		27	40	58	66	86	100	125	200
$P_{max}$ kW	L	0.25	0.7	1.1	1.9	3.6	4.7	6.4	16.0
	H	0.20	0.6	1.0	1.6	3.2	4.1	5.6	15.0

# SERIES BD

## CRITICAL TRAVELLING NUT SPEED

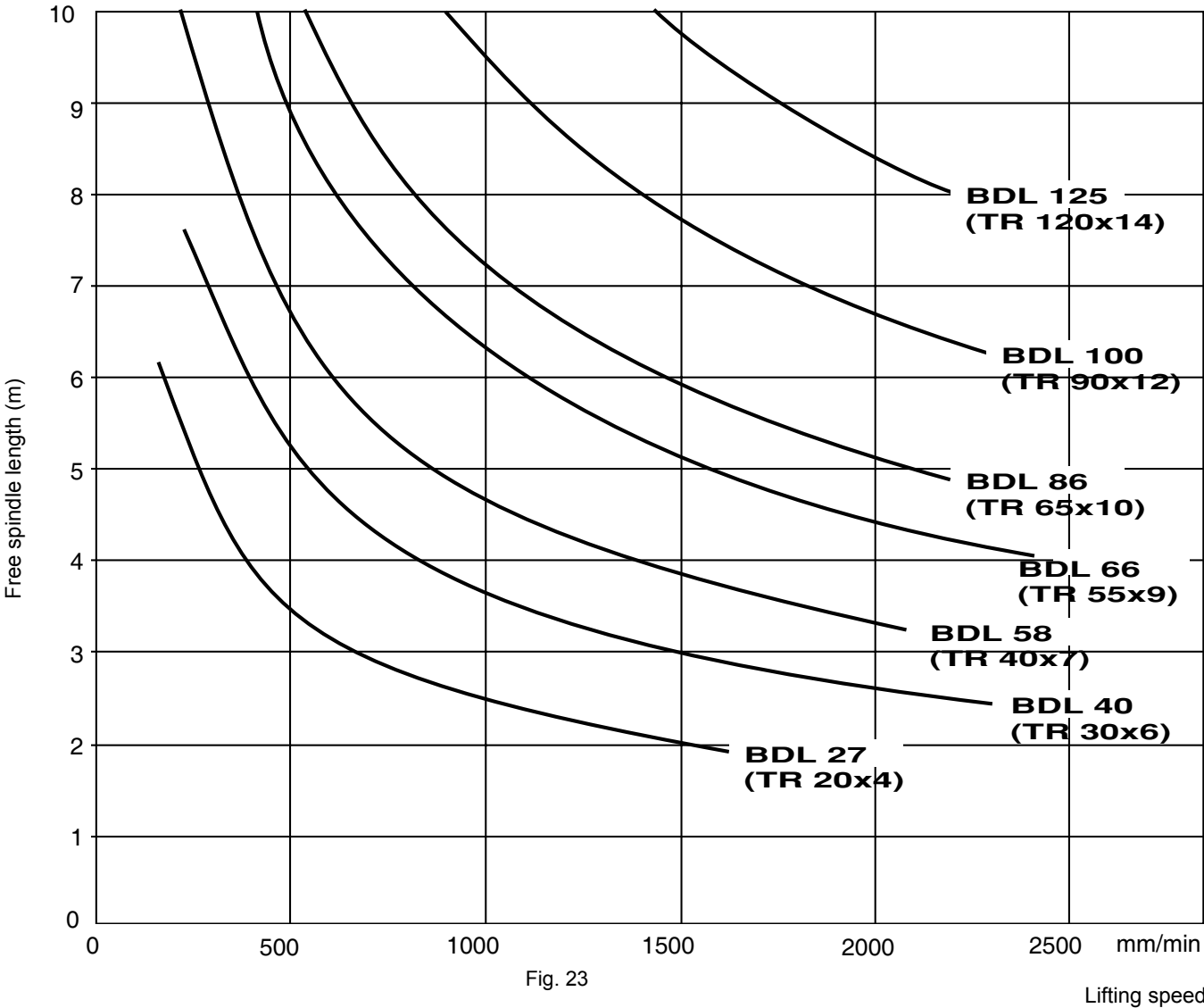

Fig. 23

Lifting speed

### Max permissible speed V mm/min with grease lubrication

BD/BDL Single start	Ratio	
	L	H
27	1600	500
40	2300	500
58	2100	500
66	2400	600
86	2200	550
100	2300	550
125	2200	550
200	1180	410

BD/BDL Double start	Ratio
	L
27	3200
40	4600
58	4200
66	4800
86	4400
100	4600
125	4400
200	2360



# SERIES BD

## ALLOWABLE SIDE FORCE ON THE SPINDLE BD

$F_a$  = thrust load on spindle (kN)  
 $F_r$  = side force on the spindle (kN)  
 $l$  = length of stroke (mm)

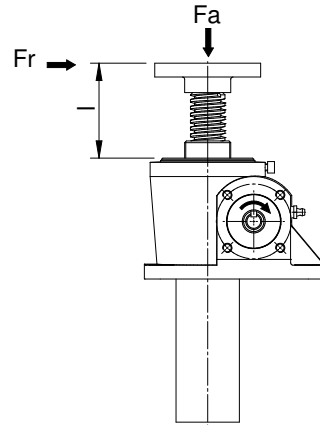
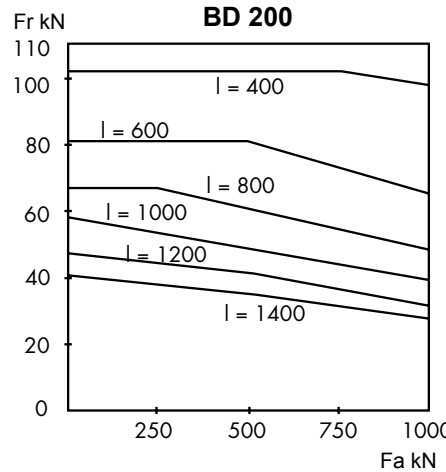
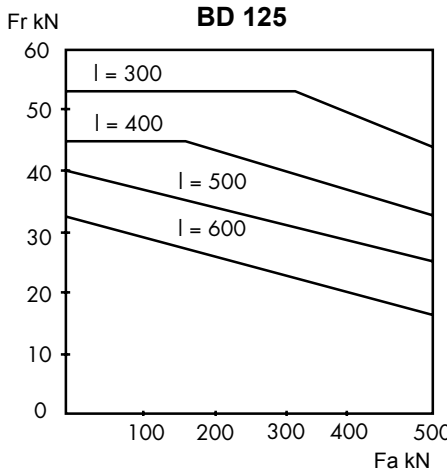
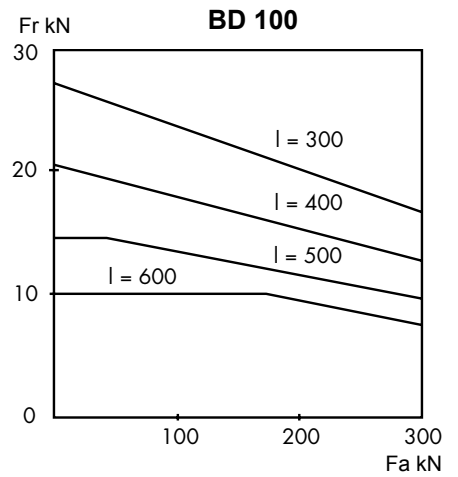
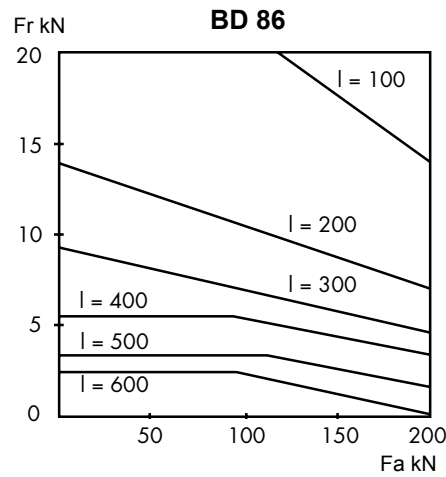
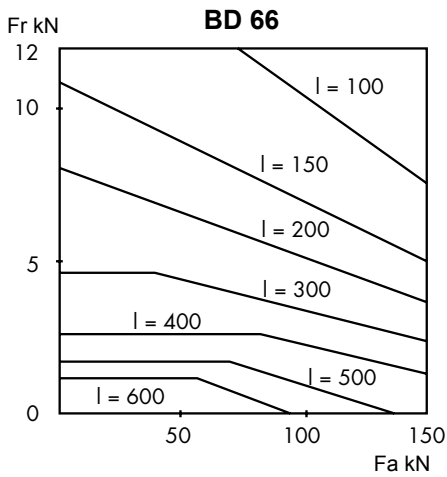
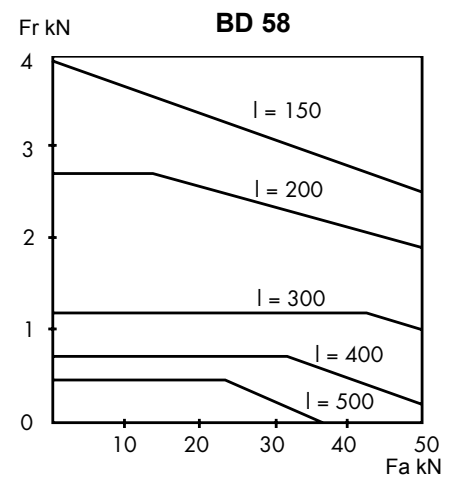
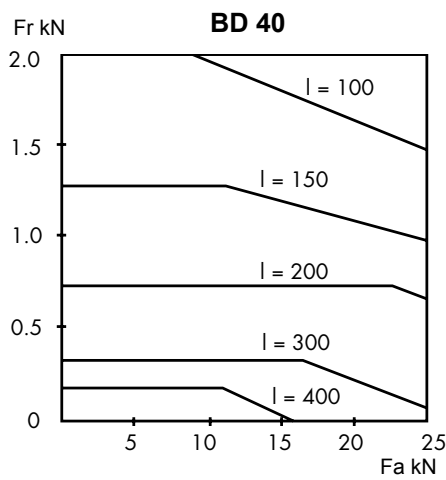
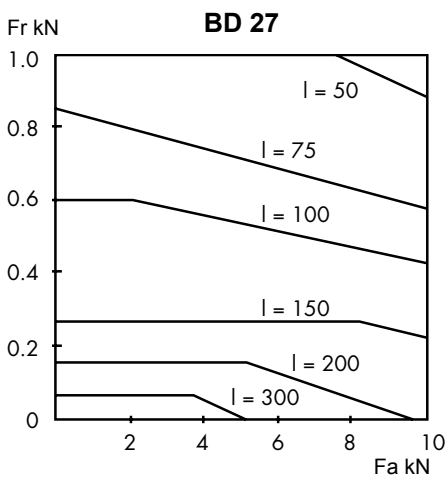
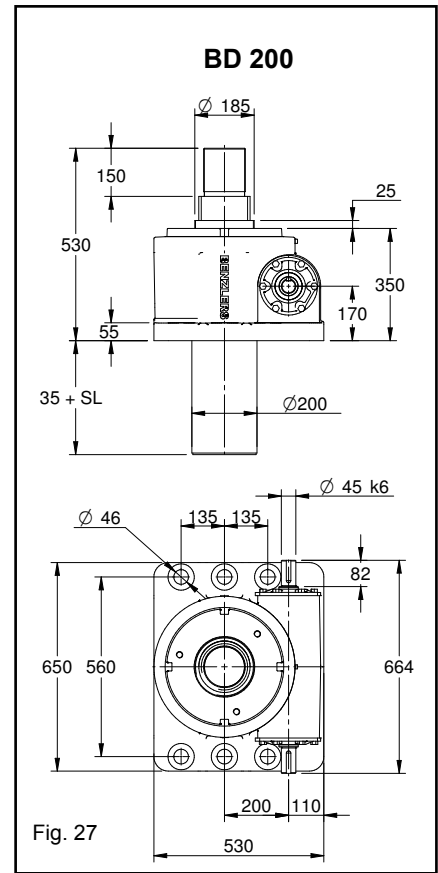
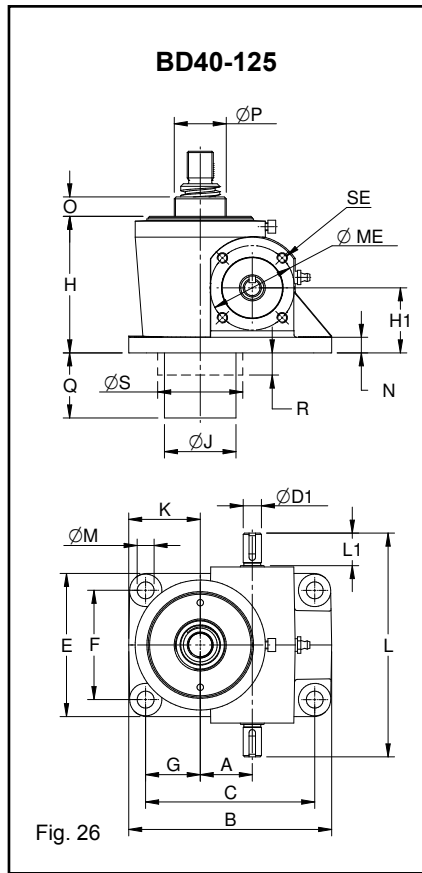
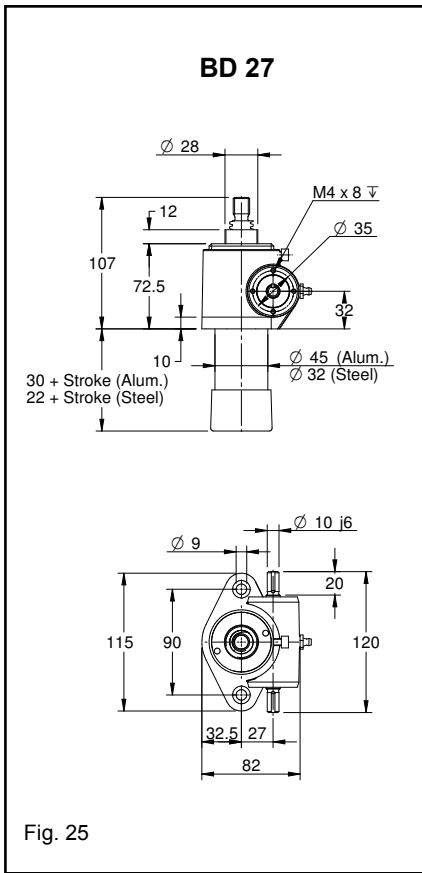

Fig. 24



# SERIES BD

## DIMENSIONS



Size	40	58	66	86	100	125
A	40	58	66	86	100	125
B	156	196	222	300	350	460
C	130	158	178	250	280	380
Ø D1j6	14	19	24	30	35	38
E	110	170	190	220	260	300
F	84	134	146	170	190	220
G	42	40	51	85	95	140
H	105	130	157	182	225	275
H1	50	55	68	80	102	125
Ø J-Aluminium	55	70	88	125	120	150
Ø J-Steel	45	55	75	90	120	150
K	55	60	73	110	130	180
L	172	237	268	318	356	486
L1	25	35	40	47	58	58
Ø M	13	18	21	26	35	42
N	12	12	16	20	25	35
O	15	15	15	20	20	25
Ø P	40	50	70	80	110	140
Q-Aluminium	30 + Stroke	30 + Stroke	30 + Stroke	35 + Stroke	-	-
Q-Steel	25 + Stroke	25 + Stroke	25 + Stroke	45 + Stroke	45 + Stroke	55 + Stroke
R	-	-	-	-	45	55
S	-	-	-	-	132	160
SE	M8 x 12	M8 x 12	M8 x 12	M10 x 15	M10 x 15	-
ME	65	80	80	88	96	-

# SERIES BD

## DIMENSIONS

### BD 27-200 END EXECUTION 1, 2, 3

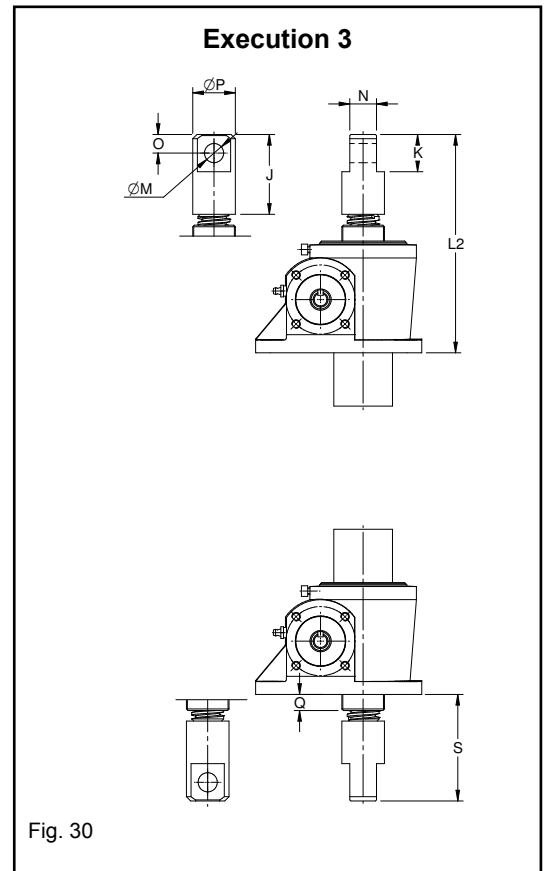
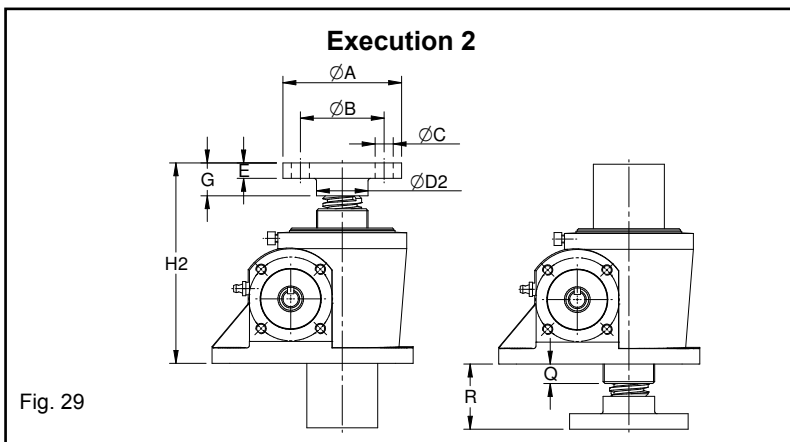
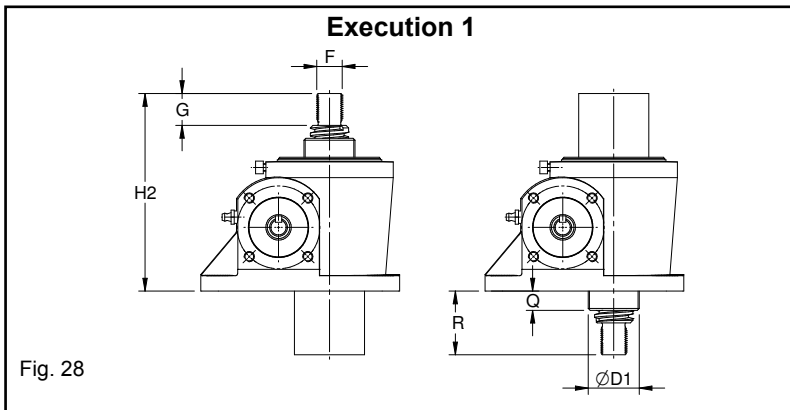

Size	27	40	58	66	86	100	125	200
Ø A	65	92	122	150	185	215	285	380
Ø B	50	65	90	110	140	170	220	290
Ø C	4x7	4x14	4x18	4x21	4x26	6x26	6x33	6x48
Ø D1	28	40	50	70	80	110	140	185
Ø D2	30	40	55	70	90	120	150	200
E	8	12	16	20	25	25	32	60
F	M14x2	M20x1.5	M30x2	M40x3	M50x3	M70x4	M90x4	M130x4
G	20	25	36	50	60	85	110	150
H2	107	150	186	227	267	335	415	530
J	55	75	100	125	160	200	265	360
K	25	35	50	60	80	100	130	180
L2	142	200	250	302	367	450	570	740
Ø M H11	12	18	25	30	40	50	65	90
N	20	25	35	45	60	80	100	140
O	12.5	17.5	25	30	40	50	65	90
Ø P	30	40	55	70	90	120	150	200
Q	12	15	15	15	20	20	25	25
R	37	45	56	70	85	110	140	180
S	72	95	120	145	185	225	295	390

# SERIES BD

## DIMENSIONS BDL 27-200

**BDL without Bellows**

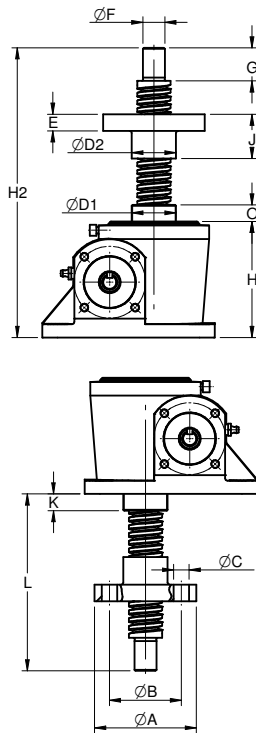

**BDL with Bellows**

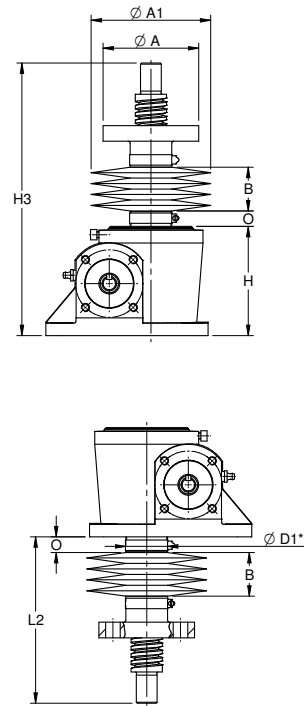

Fig. 31

Size	27	40	58	66	86	100	125	200
Ø A	65	92	122	150	185	215	285	380
Ø B	50	65	90	110	140	170	220	290
Ø C	4x7	4x14	4x18	4x21	4x26	6x26	6x33	6x48
Ø D1*	28	40	50	70	80	110	140	185
Ø D2	30	40	55	70	90	120	150	200
E	10	15	20	25	30	35	50	90
ØF h7	12	20	30	40	50	70	100	140
G	20	30	40	60	60	90	120	160
H	70	105	130	157	182	225	275	350
H2	148 + Stroke	215 + Stroke	265 + Stroke	332 + Stroke	365 + Stroke	465 + Stroke	580 + Stroke	770 + Stroke
J	25	40	55	75	85	110	140	200
K	12	15	15	15	20	20	25	25
L	84 + Stroke	115 + Stroke	155 + Stroke	196 + Stroke	205 + Stroke	261 + Stroke	330 + Stroke	430 + Stroke
O	12	15	15	15	20	20	25	25
B1	0.05 x Stroke**							
H3	148 + B1 + Stroke	215 + B1 + Stroke	265 + B1 + Stroke	332 + B1 + Stroke	365 + B1 + Stroke	465 + B1 + Stroke	580 + B1 + Stroke	***
L2	L + B1							

\* Hole to fit Hose clamp should be minimum  $\text{ØE} + 30$

\*\* Minimum B1 dimension will be 5 mm ( i.e. when Stroke is below 100mm)

\*\*\* Please contact your local sales office for more details

# SERIES BD

## DIMENSIONS

### WITH PVC BELLOWS BD 27-125

#### BD 27-125

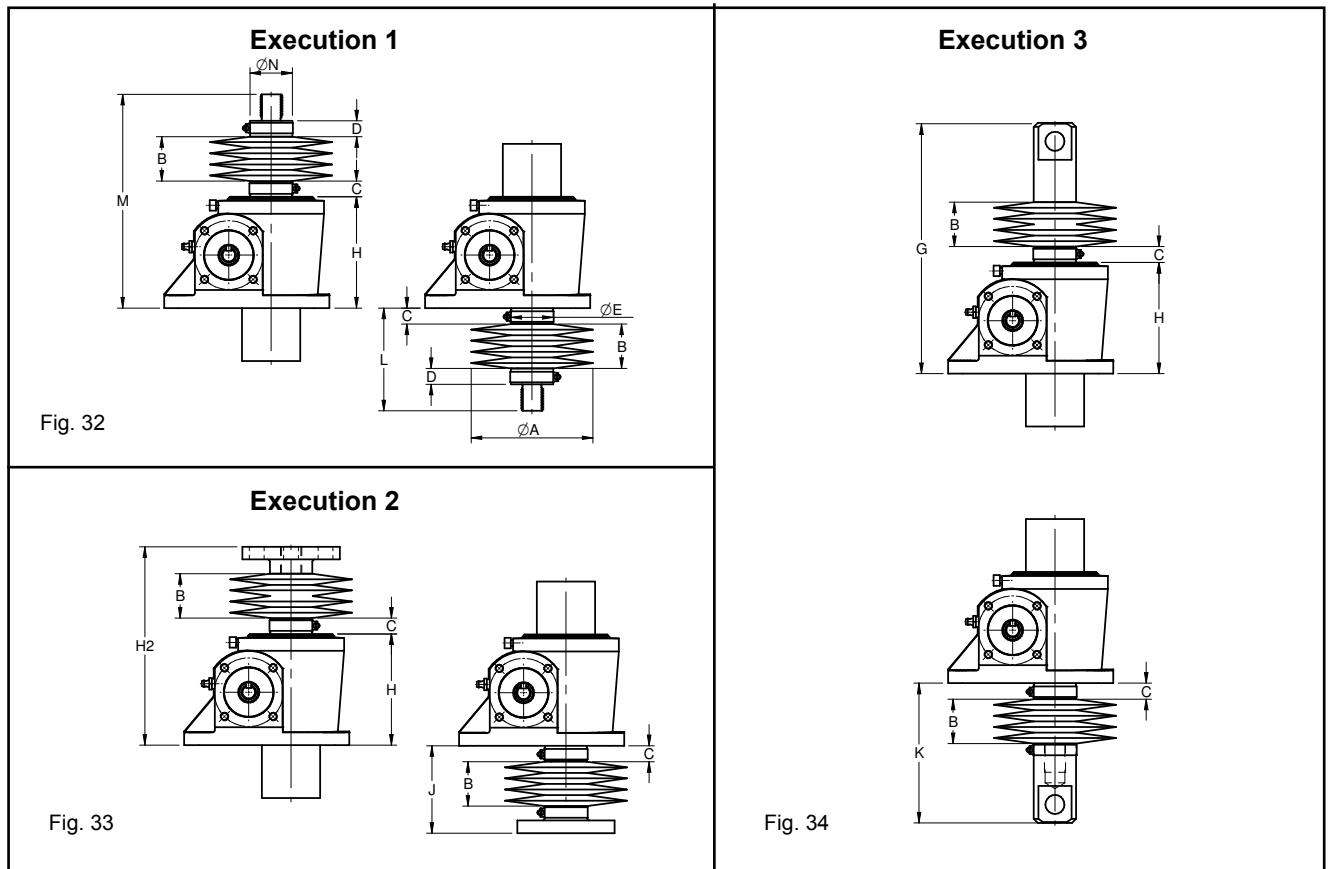

Size	27	40	58	66	86	100	125
Ø A	95	115	130	150	190	225	270
B	0.05 x Stroke**						
C	12	15	15	15	20	20	25
D	15	15	15	15	15	15	15
Ø E*	28	40	50	70	80	110	140
F	102 + B	145 + B	181 + B	222 + B	262 + B	330 + B	410 + B
G	137 + B	195 + B	245 + B	297 + B	362 + B	445 + B	565 + B
H	70	105	130	157	182	225	275
J	32 + B	40 + B	51 + B	65 + B	80 + B	105 + B	135 + B
K	67 + B	90 + B	115 + B	140 + B	180 + B	220 + B	290 + B
L	47 + B	55 + B	66 + B	80 + B	95 + B	120 + B	150 + B
M	117 + B	160 + B	196 + B	237 + B	277 + B	345 + B	425 + B
N	30	40	55	70	90	120	150

\*Hole to fit Hose clamp should be minimum  $\text{ØE} + 30$

\*\* Minimum B dimension will be 5 mm (i.e. when Stroke is below 100mm)

**Please contact your local sales office for BD200 Dimensions**

## OPTIONS

### STOP NUT (SM)

Stop nuts can be fitted to all screw jacks, both in upward and inverted executions.

These must be included when there is an inherent risk of over travel resulting in the spindle becoming disengaged from the worm thread.

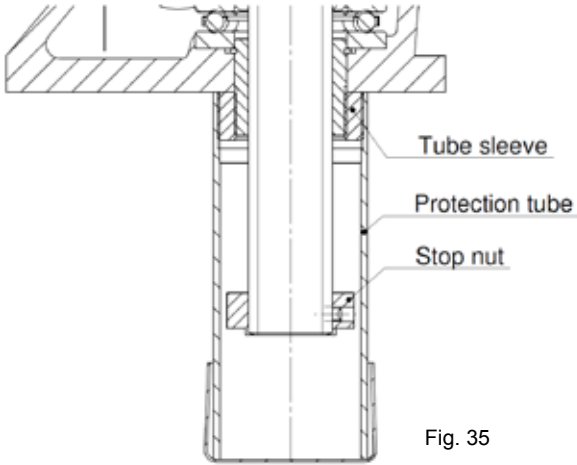

### TELEMECHANICAL LIMIT SWITCH (LS)

All jacks can be supplied with limit switches to suit most applications. Standard is two limit switches and one stop nut.

Upper/lower limits can be mounted on the protection tube.

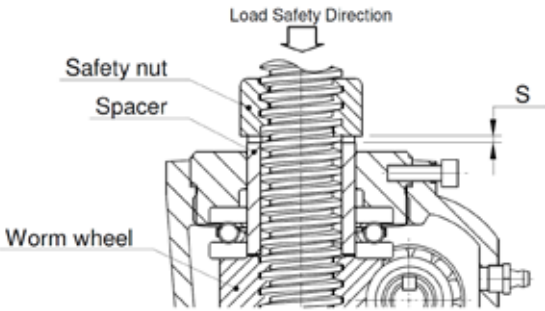
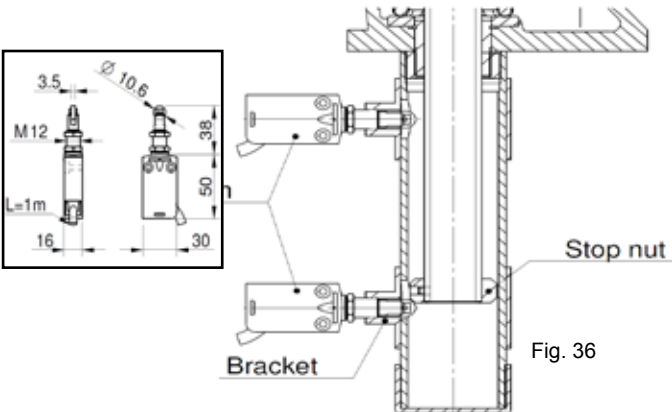

### SAFETY NUT (SHM)

In certain applications the addition of a safety nut may be required. The object of the above is to prevent the load collapsing in the event of the lifting nut thread failing.

Monitoring of the safety gap between the lifting and safety nut gives an indication of the intermediate wear. When the safety gap reaches zero the lifting nut has reached its wear limit and requires changing.

Load direction important!

Combinations with other options are restricted. Consult our local sales representative for more information.

Fig. 37

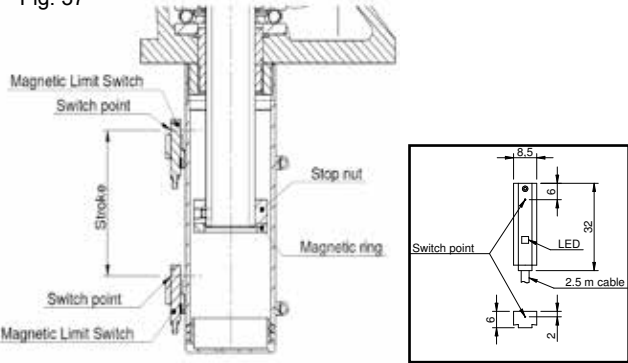

### MAGNETIC LIMIT SWITCH (MLS)

Jack size 27 to 86 can be supplied with magnetic limit switches to suit most applications. Standard is two magnetic switches and one stop nut. More limit switches can be added if needed.

Upper / lower limits can be mounted on the protection tube.

### LOCKED AGAINST ROTATION

For applications where a load is to be raised/lowered and permanent fixing i.e. top plate/clevis, is not practical, the spindle must be prevented from rotating.

Two options are available:

#### I) LR - Locked Against Rotation (Tube)

Protection tube manufactured in box section mild steel. Spindle end complete with nut (sized to suit box section). This option cannot be added along with Stop nut option.

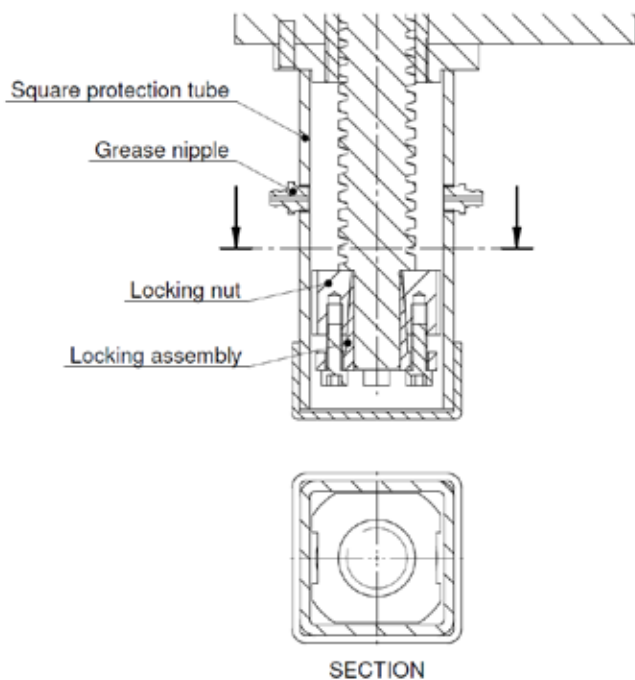

Fig. 38

#### II) LRK - Locked Against Rotation (Key)

Jack internals are modified to incorporate a rectangular key which engages in a precision keyway cut into the spindle length. Primarily used in precision applications requiring minimal radial movement.

Combinations with other options are restricted.

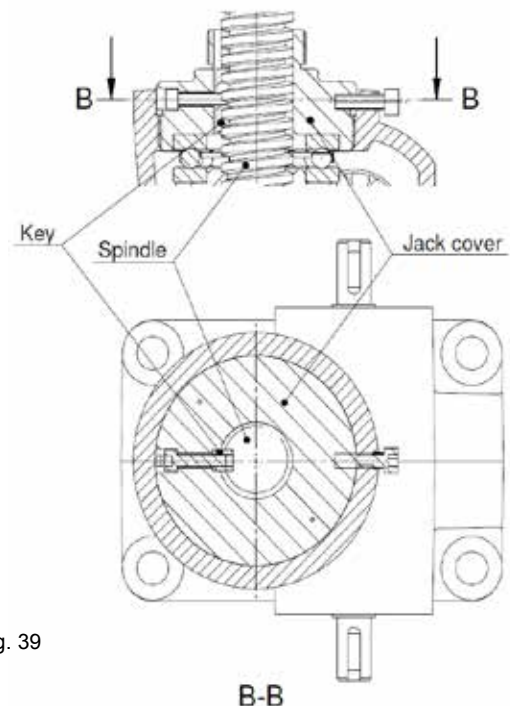

Fig. 39

### ANTIBACKLASH (ABL)

Where the loading on a screw jack can be in both tension and compression and the spindle backlash is critical, units can be supplied with a Back-lash Eliminator comprising of a modified worm wheel fitted with a secondary nut, allowing contact on both face and flank of driving thread.

The backlash eliminator reduces the backlash to 0.01 – 0.05 mm. As the thread is worn, adjustment has to be done to counter the wear. Adjustment can be done until the thread pitch has been reduced by 25%.

Combinations with other options are restricted.

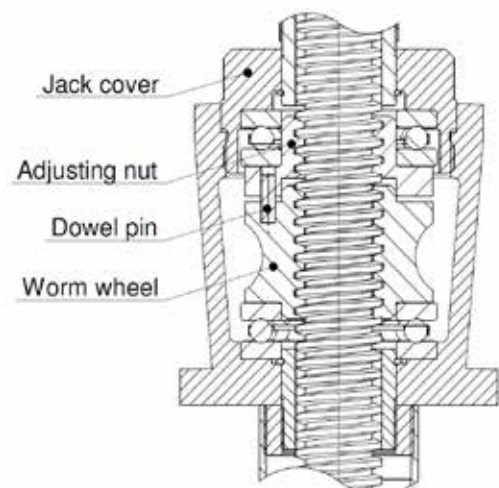

Fig. 40

# SERIES BD

## DIMENSIONS

### SM - LR - LRK - ABL

Dimensions for BD200 consult your local Benzlers sales office.

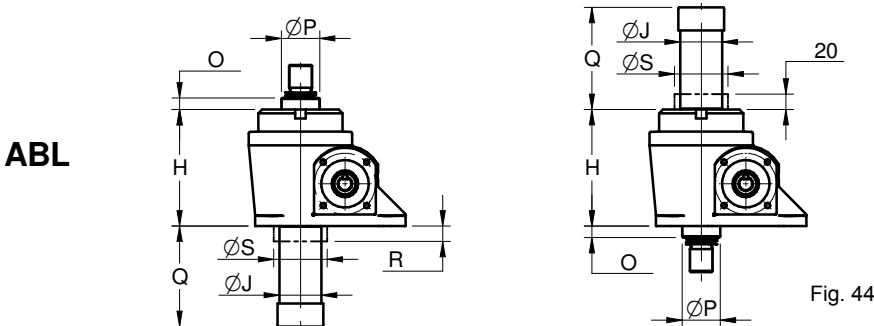
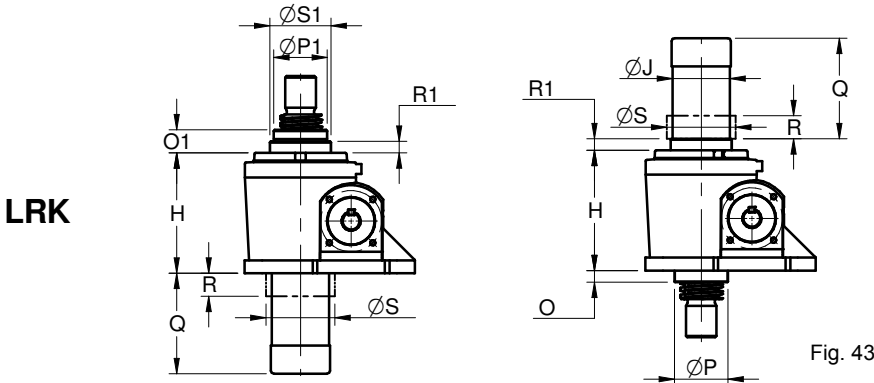
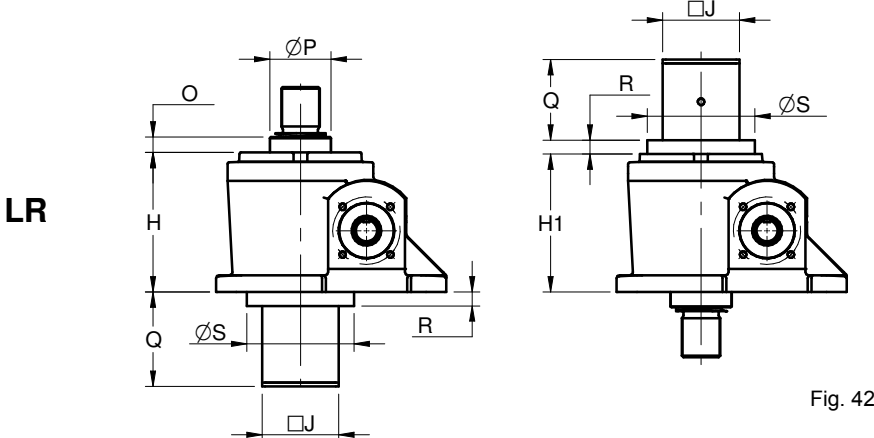
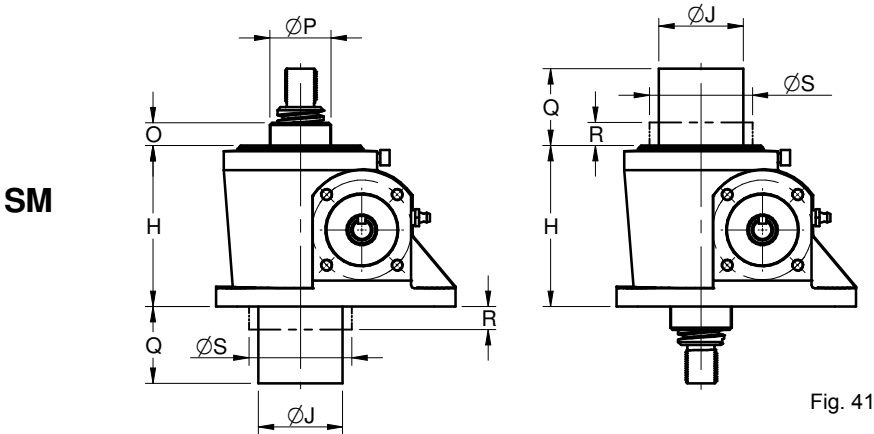



# SERIES BD

## DIMENSIONS

### SM - LR - LRK - ABL

Size	SM							
	27	40	58	66	86	100	125	
H	72.5	105	130	157	182	225	275	
J	Steel	45	55	75	90	102	152	171
	Aluminium	45	55	70	88	125	-	-
O	12	15	15	15	20	20	25	
P	28	40	50	70	80	110	140	
Q	Steel	34 + SL	43 + SL	48 + SL	62 + SL	74 + SL	91 + SL	111 + SL
	Aluminium	69 + SL	77 + SL	82 + SL	96 + SL	111 + SL	-	-
R-Steel	-	-	-	-	45	50	55	
S-Steel	-	-	-	-	110	160	190	

Size	LR						
	27	40	58	66	86	100	125
H	72.5	105	130	157	182	225	275
H1	72.5	103	128	155	180	223	273
J-Steel	40x40	60x60	70x70	80x80	100x100	120x120	150x150
O	12	15	15	15	20	20	25
P	28	40	50	70	80	110	140
Q - Steel	66+SL	77+SL	86+SL	120+SL	123+SL	155+SL	185+SL
R-Steel	8	10	10	15	18	18	30
S-Steel	55	80	100	110	140	180	215

Size	LRK							
	27	40	58	66	86	100	125	
H	70	105	130	157	182	225	275	
J	Steel	32	45	55	75	90	121	150
	Aluminium	45	55	70	88	125	-	-
O	12	15	15	15	20	20	25	
O1	22	20	15	32	22	46	26	
P	28	40	50	70	80	110	140	
P1	28	40	50	70	90	110	150	
Q	Steel	22 + SL	25 + SL	25 + SL	25 + SL	45 + SL	45 + SL	55 + SL
	Aluminium	35 + SL	35 + SL	35 + SL	35 + SL	40 + SL	-	-
R1	10	5	-	17	-	26	-	
S1	36	50	-	80	-	120	-	
R-Steel	-	-	-	-	45	45	55	
S-Steel	-	-	-	-	100	132	160	

Size	ABL							
	27	40	58	66	86	100	125	
H	83	120	152	190	235	288	350	
F	55	80	10	120	160	200	240	
J	Steel	32	45	55	75	90	121	150
	Aluminium	45	55	70	88	125	-	-
O	12	15	15	15	20	20	25	
P	28	40	50	70	80	110	140	
Q	Steel	22 + SL	25 + SL	25 + SL	25 + SL	45 + SL	45 + SL	55 + SL
	Aluminium	35 + SL	35 + SL	35 + SL	35 + SL	40 + SL	-	-
R-Steel	-	-	-	-	45	45	55	
S-Steel	-	-	-	-	100	132	160	

# SERIES BD

## DIMENSIONS MLS-LS-RPT

MLS

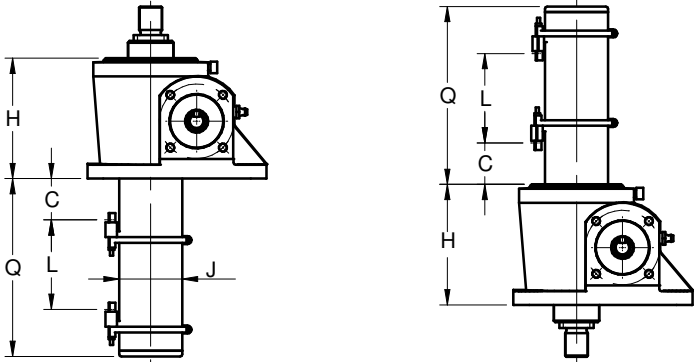

Fig. 45

LS

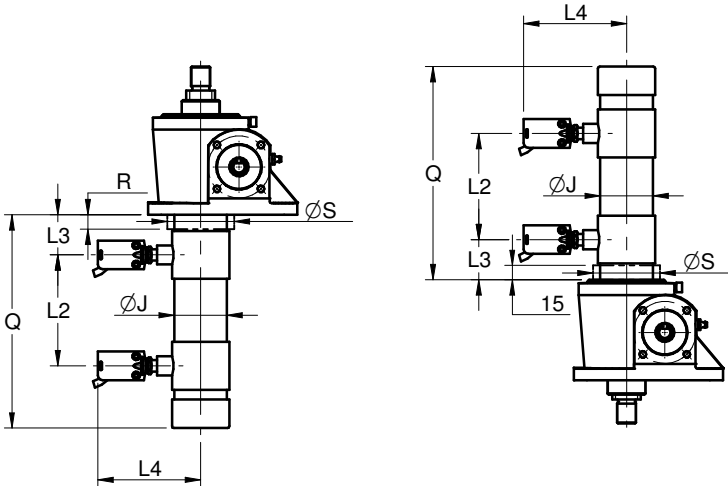

Fig. 46

RPT

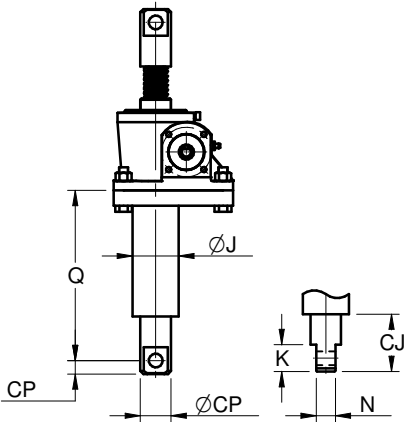

Fig. 47

# SERIES BD

## DIMENSIONS MLS-LS-RPT

Size	MLS				
	27	40	58	66	86
C	41	43	48	63	73
H	72.5	105	130	157	182
J - Aluminium	45	55	70	88	125
Q - Aluminium	69 + SL	77 + SL	82 + SL	96 + SL	111 + SL
L	SL	SL	SL	SL	SL

Size	LS						
	27	40	58	66	86	100	125
J - Steel	45	55	75	90	121	152	194
L2	6 + SL	11 + SL	15 + SL	30 + SL	40 + SL	50 + SL	55 + SL
L3	42	42	42	60	81	63	67
L4	98	105	112	120	131	148	166
Q -Steel	115 + SL	120 + SL	124 + SL	157 + SL	191 + SL	180 + SL	189 + SL
R-Steel	-	-	-	37	45	50	60
S-Steel	-	-	-	100	132	160	210

Size	RPT				
	27	40	58	66	86
CJ	55	75	100	125	160
CO	12.5	17.5	25	30	40
CP	30	40	55	70	90
J-Steel	48.5	60.5	82.5	101.5	121
K	25	35	50	60	80
M h11	12	18	25	30	40
N	20	25	35	45	60
Q	96 + SL	123 + SL	144 + SL	185 + SL	235 + SL
Max SL*	250	400	400	500	500

\* For longer stroke lengths, please contact your local Benzlers sales office

SL-Stroke Length

# SERIES BD

## DIMENSIONS

### SHM - SAFETY NUT

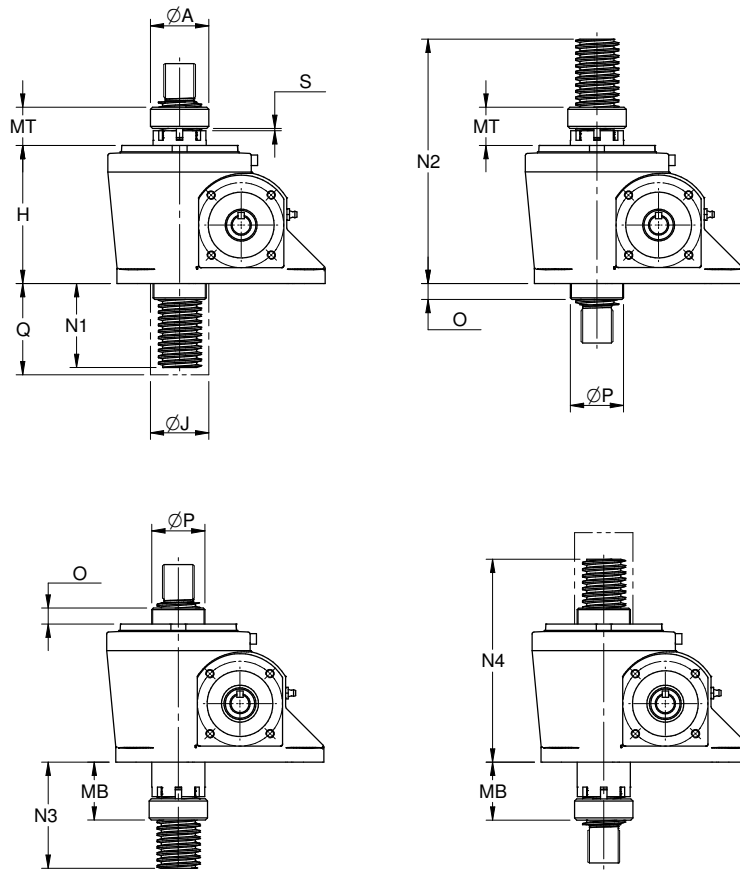

Fig. 48

Size	SHM						
	27	40	58	66	86	100	125
A	30	45	55	75	90	120	170
H	72.5	105	130	157	182	225	275
J - alu.	45	55	75	90	102	152	171
J - steel	45	55	70	88	125	-	-
N1	12 + SL	15 + SL	15 + SL	15 + SL	20 + SL	*	*
N2	90	132	165	209	248	*	*
N3	47.5	62	80	112	136	-	-
N4	76	115	125	151	180	-	-
MB	26	32	55	73	88	-	-
MT	17.5	27	36	53	68	111.5	118
O	12	15	15	15	20	20	25
P	28	40	50	70	80	110	140
Q - alu.	22 + SL	25 + SL	25 + SL	25 + SL	45 + SL	45 + SL	55 + SL
Q - steel	35 + SL	35 + SL	35 + SL	35 + SL	40 + SL	-	-
S	1.0 - 1.5	1.5 - 2.2	1.8 - 2.5	2.3 - 3.3	2.5 - 3.3	3.0 - 4.44	3.5 - 5.18

\* For these dimensions, please contact your local Benzlers sales office

SL-Stroke Length

# SERIES BD

## DIMENSIONS

### SM - LR - LRK - ABL - MLS

Dimensions for BD200 consult your local Benzlers sales office.

#### Without bellows

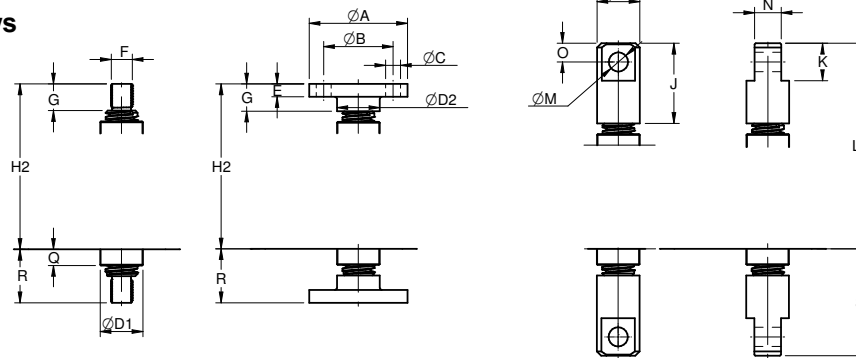

Fig. 49

Size		27	40	58	66	86	100	125
Dia A		65	92	122	150	185	215	285
Dia B		50	65	90	110	140	170	220
Dia C		4 x 7	4 x 14	4 x 18	4 x 21	4 x 26	6 x 26	6 x 33
Dia D1		28	40	50	70	80	110	140
Dia D2		30	40	55	70	90	120	150
E		8	12	16	20	25	25	32
F		M14 x 2	M20 x 1.5	M30 x 2	M40 x 3	M50 x 3	M70 x 4	M90 x 4
G		20	25	36	50	60	85	110
H2	SM	107+SL	150+SL	186+SL	227+SL	267+SL	335+SL	415+SL
	LR	107+SL	150+SL	186+SL	227+SL	267+SL	335+SL	415+SL
	LRK	117+SL	155+SL	186+SL	242+SL	267+SL	361+SL	415+SL
	ABL	119+SL	165+SL	207+SL	260+SL	320+SL	398+SL	490+SL
	MLS	107+SL	150+SL	186+SL	227+SL	267+SL	-	-
J		55	75	100	125	160	200	265
K		25	35	50	60	80	100	130
L2	SM	142+SL	200+SL	250+SL	302+SL	367+SL	450+SL	570+SL
	LR	142+SL	200+SL	250+SL	302+SL	367+SL	450+SL	570+SL
	LRK	152+SL	205+SL	250+SL	317+SL	367+SL	476+SL	570+SL
	ABL	154+SL	215+SL	271+SL	335+SL	420+SL	513+SL	645+SL
	MLS	142+SL	200+SL	250+SL	302+SL	367+SL	-	-
Dia M H11		12	18	25	30	40	50	65
N		20	25	35	45	60	80	100
O		12.5	17.5	25	30	40	50	65
Dia P		30	40	55	70	90	120	150
Q		12	15	15	15	20	20	25
R	SM	37+SL	45+SL	56+SL	70+SL	85+SL	110+SL	140+SL
	LR	37+SL	45+SL	56+SL	70+SL	85+SL	110+SL	140+SL
	LRK	37+SL	45+SL	56+SL	70+SL	85+SL	110+SL	140+SL
	ABL	37+SL	45+SL	56+SL	70+SL	85+SL	110+SL	140+SL
	MLS	37+SL	45+SL	56+SL	70+SL	85+SL	-	-
S	SM	72+SL	95+SL	120+SL	145+SL	185+SL	225+SL	295+SL
	LR	72+SL	95+SL	120+SL	145+SL	185+SL	225+SL	295+SL
	LRK	72+SL	95+SL	120+SL	145+SL	185+SL	225+SL	295+SL
	ABL	72+SL	95+SL	120+SL	145+SL	185+SL	225+SL	295+SL
	MLS	72+SL	95+SL	120+SL	145+SL	185+SL	-	-

SL-Stroke Length

# SERIES BD

## DIMENSIONS SM - LR - LRK - ABL-MLS

Dimensions for BD200 consult your local Benzlers sales office.

With bellows

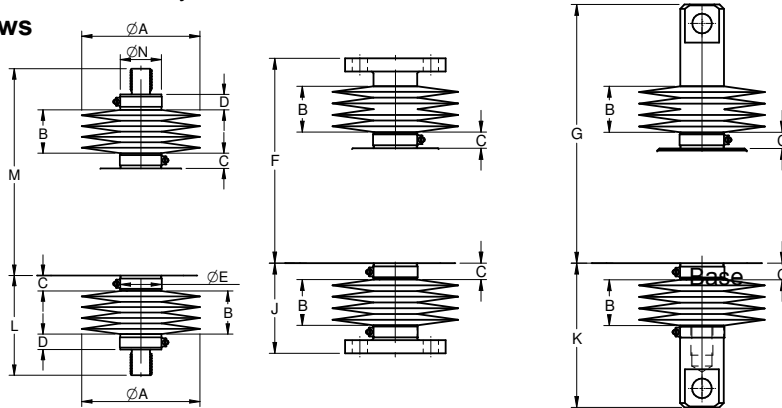

\*\*Hole for Hose clamp

\*Minimum B dimension will be 5 mm (i.e. when Stroke is below 100mm)

Fig. 50

Size		27	40	58	66	86	100	125
A		95	115	130	150	190	225	270
B		0.05 x SL*						
C		12	15	15	15	20	20	25
D		15	15	15	15	15	15	15
E**		28	40	50	70	80	110	140
F	SM	102 + B	145 + B	181 + B	222 + B	262 + B	330 + B	410 + B
	LR	102 + B	145 + B	181 + B	222 + B	262 + B	330 + B	410 + B
	LRK	112 + B	150 + B	181 + B	237 + B	262 + B	356 + B	410 + B
	ABL	114 + B	160 + B	203 + B	255 + B	315 + B	393 + B	485 + B
	MLS	102 + B	145 + B	181 + B	222 + B	262 + B	-	-
G	SM	137 + B	195 + B	245 + B	297 + B	362 + B	445 + B	565 + B
	LR	137 + B	195 + B	245 + B	297 + B	362 + B	445 + B	565 + B
	LRK	147 + B	200 + B	245 + B	312 + B	362 + B	471 + B	565 + B
	ABL	149 + B	210 + B	267 + B	330 + B	415 + B	508 + B	640 + B
	MLS	137 + B	195 + B	245 + B	297 + B	362 + B	-	-
J	SM	32 + B	40 + B	51 + B	65 + B	80 + B	105 + B	135 + B
	LR	32 + B	40 + B	51 + B	65 + B	80 + B	105 + B	135 + B
	LRK	32 + B	40 + B	51 + B	65 + B	80 + B	105 + B	135 + B
	ABL	32 + B	40 + B	51 + B	65 + B	80 + B	105 + B	135 + B
	MLS	32 + B	40 + B	51 + B	65 + B	80 + B	-	-
K	SM	67 + B	90 + B	115 + B	140 + B	180 + B	220 + B	290 + B
	LR	67 + B	90 + B	115 + B	140 + B	180 + B	220 + B	290 + B
	LRK	67 + B	90 + B	115 + B	140 + B	180 + B	220 + B	290 + B
	ABL	67 + B	90 + B	115 + B	140 + B	180 + B	220 + B	290 + B
	MLS	67 + B	90 + B	115 + B	140 + B	180 + B	-	-
L	SM	47 + B	55 + B	66 + B	80 + B	95 + B	120 + B	150 + B
	LR	47 + B	55 + B	66 + B	80 + B	95 + B	120 + B	150 + B
	LRK	47 + B	55 + B	66 + B	80 + B	95 + B	120 + B	150 + B
	ABL	47 + B	55 + B	66 + B	80 + B	95 + B	120 + B	150 + B
	MLS	47 + B	55 + B	66 + B	80 + B	95 + B	-	-
M	SM	117 + B	160 + B	196 + B	237 + B	277 + B	345 + B	425 + B
	LR	117 + B	160 + B	196 + B	237 + B	277 + B	345 + B	425 + B
	LRK	127 + B	165 + B	196 + B	252 + B	277 + B	371 + B	425 + B
	ABL	129 + B	175 + B	218 + B	270 + B	330 + B	408 + B	500 + B
	MLS	117 + B	160 + B	196 + B	237 + B	277 + B	-	-
N		30	40	55	70	90	120	150

## DESCRIPTION OF BDK - BDKL

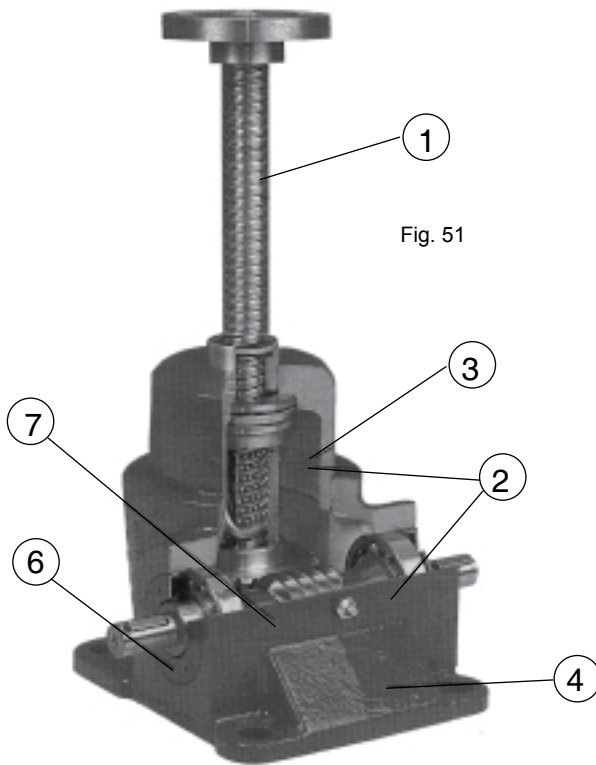

Fig. 51

- 1 Ball screw
- 2 Thrust and radial bearings
- 3 Grease of EP-quality
- 4 Housing of nodular cast iron
- 5 Alkyd paint 85 micron thick in RAL 5009
- 6 Worm screw hardened and ground
- 7 Worm wheel of centrifugally cast tin bronze
- 8 Bellows in PVC, steel or other materials(Not shown)

Ball screw jacks BDK and BDKL are at full load designed for 60% utilization (ED) per 10 minutes still not more than 30% per hour totally at ambient temperature +25°C. Ball screw jacks are filled with grease in EP-quality at delivery. The lifting screw should be lubricated with same type of grease. Allowable working temperature range is from -30°C to +100° C.

**For other conditions consult your local Benzlers office.**

**Cut Section of BDK unit**

### Technical data of BDK - BDKL

*Other capacities and screw sizes available on request*

Size	27	40	58	66
Max capacity (N)	8 000	25 000	50 000	125 000
Lifting screw	20 x 5	25 x 10	40 x 10	50 x 10
Ratio (L)	9:1	7:1	6.75:1	7:1
Raise per revolution (mm)	0.555	1.428	1.481	1.428
Starting torque at max load (Nm)	2.5	16.0	32	76
Max running power at 30% ED (kW)	0.25	0.77	2.0	2.9
Starting efficiency	0.28	0.35	0.39	0.37
Starting torque on lifting screw at max load (Nm)	9	56	114	292
Running efficiency	See page "Power ratings" page 42-43			
*Holding torque (Nm))	0.35	2.5	6.0	14.0
Weight with 100 mm stroke BDK/BDKL (kg)	4/3.5	11/10	26/20	40/34
Weight of lifting screw, 100 mm (Kg)	0.2	0.32	0.84	1.36

\* The holding torque is the torque on the input shaft which is required to prevent the load from being lowered.

# SERIES BD

## COMPRESSION LOAD TABLE BDK-BDKL

**Compression load table BDK-BDKL Loadcase I**

Size		27	40	58	66
Max capacity (kN)		8	25	50	125
Max capacity, compression load (kN) for different lengths of stroke at threefold safetyfactor against breaking (Loadcase I)  <i>Free load</i>	0.2	*	*	*	*
	0.3	6.6	18	*	*
	0.4	3.7	10	*	*
	0.5	(2.4)	6.6	40	119
	0.6		(4.6)	28	83
	0.7			20	61
	0.8			16	46
	0.9			(12)	37
	1.0			(10)	30
	1.25				(19)
	1.50				
	1.75				
	2.00				
	2.25				
2.50					

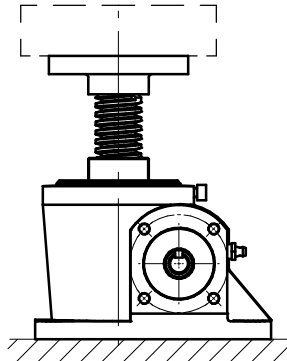

Free spindle length (m)

Fig. 52

**Compression load table BDK-BDKL Loadcase II**

Size		27	40	58	66
Max capacity (kN)		8	25	50	125
Max capacity, compression load (kN) for different lengths of stroke at threefold safetyfactor against breaking (Loadcase II)  <i>Guided load</i>	0.2	*	*	*	*
	0.3	*	*	*	*
	0.4	*	*	*	*
	0.5	*	*	*	*
	0.6	6.6	18	*	*
	0.7	4.9	13	*	*
	0.8	3.7	10	*	*
	0.9	(3.0)	8.1	*	*
	1.0	(2.4)	6.6	40	119
	1.25		(4.2)	26	76
	1.50			18	53
	1.75			(13)	39
	2.00			(10)	30
	2.25				(24)
2.50				(19)	

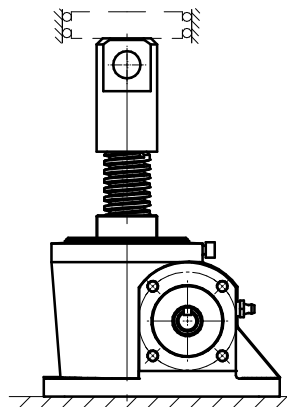

Free spindle length (m)

Fig. 53

The values given in brackets must only be used at low lifting speed and concentric load on the lifting screws.

\*- Maximum Capacity



# SERIES BD

## COMPRESSION LOAD TABLE BDK-BDKL

Compression load table BDK-BDKL Loadcase III

Size		27	40	58	66
Max capacity (kN)		8	25	50	125
Max capacity, compression load (kN) for different lengths of stroke at threefold safetyfactor against breaking (Loadcase III)	0.2	*	*	*	*
	0.3	*	*	*	*
	0.4	*	*	*	*
	0.5	*	*	*	*
	0.6	*	*	*	*
	0.7	*	*	*	*
	0.8	7.7	21	*	*
	0.9	5.9	16	*	*
	1.0	4.8	13	*	*
	1.25	(3.0)	8.4	*	*
	1.50		5.8	36	106
	1.75		(4.3)	26	78
	2.00			20	60
	2.25			16	47
	2.50			(13)	38
	3.00				26
3.50				(19)	

*Guided load*

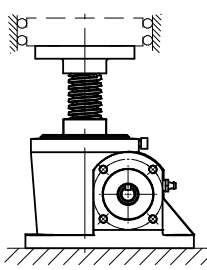

*Supported spindle*

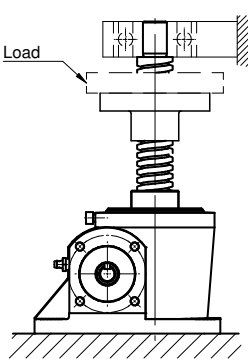

Free spindle length (m)

Fig. 54

\*- Maximum Capacity

The values given in brackets must only be used at low lifting speed and concentric load on the lifting screws.

## Power ratings BDK - BDKL

Power ratings for BDK-BDKL at 60% ED/10 min or max 30% ED/hour at ambient temperature +25°C.

Thermal capacity:

The figures above the line in ***italics*** can only be used at ED lower than 30%. Thermal power must be checked. See "Intermittence factor (ED) BD/BDL" on page 27.

- n = input speed (rpm)
- v = lifting speed (mm/min)
- $\eta_d$  = running efficiency
- L = low ratio
- T = input torque (Nm)
- P = input power (kW)
- i = ratio of worm gear set

**Note:** Power ratings indicate running power. Additional power will be required on start. See "Selection of jacks".

### BDK 27 L (i = 9) 20 x 5

n rpm	v mm/min	$\eta_d$	8 kN		6 kN		4 kN		2 kN		1 kN	
			Nm	kW	Nm	kW	Nm	kW	Nm	kW	Nm	kW
2900	1611	.46	<b>1.5</b>	<b>.46</b>	<b>1.2</b>	<b>.36</b>	.87	.27	.56	.17	.40	.12
1750	972	.45	<b>1.5</b>	<b>.28</b>	1.2	.22	.87	.16	.56	.10	.40	.07
1500	833	.45	1.6	.25	1.3	.20	.92	.14	.58	.09	.41	.06
1000	556	.44	1.6	.17	1.3	.13	.92	.10	.58	.06	.41	.05
750	417	.43	1.6	.13	1.3	.10	.92	.07	.58	.05	.41	.05
500	278	.42	1.7	.09	1.3	.07	.97	.05	.61	.05	.42	.05
400	222	.41	1.7	.07	1.3	.06	.97	.05	.61	.05	.42	.05
300	167	.40	1.7	.05	1.3	.05	.97	.05	.61	.05	.42	.05
200	111	.39	1.8	.05	1.4	.05	1.0	.05	.63	.05	.44	.05
100	56	.37	1.9	.05	1.5	.05	1.1	.05	.66	.05	.45	.05
50	28	.35	2.0	.05	1.6	.05	1.1	.05	.68	.05	.46	.05

# SERIES BD

## POWER RATINGS BDK - BDKL

### BDK 40 L (i = 7) 25 x 10

n rpm	v mm/min	$\eta_d$	25 kN		20 kN		15 kN		10 kN		7.5 kN		5 kN		2.5 kN	
			Nm	kW	Nm	kW	Nm	kW	Nm	kW	Nm	kW	Nm	kW	Nm	kW
2700	3857	.56					<b>6.0</b>	<b>1.7</b>	<b>4.1</b>	<b>1.2</b>	<b>3.2</b>	<b>.90</b>	2.2	.63	1.3	.36
1750	2500	.55					<b>6.1</b>	<b>1.1</b>	4.2	.75	3.2	.58	2.3	.41	1.3	.24
1500	2143	.55					<b>6.1</b>	<b>.96</b>	4.2	.66	3.2	.51	2.3	.36	1.3	.20
1000	1429	.52			<b>8.6</b>	<b>.90</b>	6.5	.68	4.5	.47	3.4	.36	2.4	.25	1.4	.14
750	1071	.52			8.7	.69	6.6	.52	4.5	.36	3.5	.28	2.4	.19	1.4	.11
500	714	.51	11	.58	8.9	.47	6.8	.36	4.6	.24	3.6	.19	2.5	.13	1.4	.07
400	571	.50	11	.47	9.1	.38	6.9	.29	4.7	.20	3.6	.15	2.5	.11	1.4	.06
300	429	.49	12	.36	9.3	.29	7.0	.22	4.8	.15	3.7	.12	2.6	.08	1.5	.05
200	286	.48	12	.25	9.5	.20	7.2	.15	4.9	.10	3.8	.08	2.6	.06	1.5	.05
100	143	.46	12	.13	9.9	.10	7.5	.08	5.1	.05	3.9	.05	2.7	.05	1.5	.05
50	71	.44	13	.07	10	.06	7.9	.05	5.4	.05	4.1	.05	2.9	.05	1.6	.05

### BDK 58 L (i = 6.75) 40 x 10

n rpm	v mm/min	$\eta_d$	50 kN		40 kN		30 kN		25 kN		20 kN		15 kN		10 kN	
			Nm	kW	Nm	kW	Nm	kW	Nm	kW	Nm	kW	Nm	kW	Nm	kW
2000	2963	.58					<b>12</b>	<b>2.5</b>	<b>10</b>	<b>2.1</b>	8.2	1.7	6.3	1.3	4.4	.91
1750	2593	.58					12	2.2	10	1.8	8.2	1.5	6.3	1.1	4.4	.80
1500	2222	.58					12	1.9	10	1.6	8.3	1.3	6.4	.99	4.4	.69
1000	1481	.55			17	1.8	13	1.4	11	1.1	8.7	.93	6.7	.71	4.6	.49
750	1111	.55			17	1.3	13	.99	11	.83	8.8	.67	6.7	.51	4.7	.36
500	741	.52	23	1.2	18	.97	14	.73	12	.61	9.3	.50	7.1	.38	4.9	.26
400	593	.51	23	.95	18	.76	14	.58	12	.49	9.4	.39	7.2	.30	5.0	.21
300	444	.51	23	.72	19	.58	14	.44	12	.37	9.5	.30	7.3	.23	5.0	.16
200	296	.49	24	.49	19	.39	14	.30	12	.25	9.7	.20	7.4	.15	5.1	.11
100	148	.48	25	.26	20	.21	15	.16	13	.13	10	.11	7.7	.08	5.3	.06
50	74	.46	26	.13	21	.10	16	.08	13	.07	11	.05	8.0	.05	5.5	.05

### BDK 66 L (i = 7) 50 x 10

n rpm	v mm/min	$\eta_d$	125 kN		100 kN		75 kN		50 kN		25 kN		20 kN		10 kN	
			Nm	kW	Nm	kW	Nm	kW	Nm	kW	Nm	kW	Nm	kW	Nm	kW
1750	2500	.56							<b>20</b>	<b>3.7</b>	10	1.9	8.4	1.5	4.5	.83
1500	2143	.56							<b>20</b>	<b>3.2</b>	10	1.6	8.4	1.3	4.5	.72
1000	1429	.55							21	2.1	11	1.1	8.6	.88	4.6	.47
750	1071	.52					32	2.5	22	1.7	11	.86	9.1	.70	4.8	.37
500	714	.51					33	1.7	22	1.1	11	.59	9.2	.48	4.9	.25
300	429	.50			45	1.4	34	1.1	23	.71	12	.36	9.4	.30	5.0	.16
250	357	.50			45	1.2	34	.90	23	.61	12	.31	9.5	.25	5.0	.13
200	286	.49			46	.95	34	.72	23	.48	12	.25	9.6	.20	5.1	.11
150	214	.49	58	.91	46	.73	35	.55	23	.37	12	.19	9.7	.15	5.2	.08
125	179	.48	58	.76	47	.61	35	.46	24	.31	12	.16	9.8	.13	5.2	.07
100	143	.48	59	.62	47	.50	36	.37	24	.25	12	.13	10	.10	5.3	.06
50	71	.46	62	.32	49	.26	37	.19	25	.13	13	.07	10	.05	5.5	.05

### INTERMITTENCE FACTOR

Intermittence (ED%) is the percentage of time in which the screw jack is running.

If the intermittence (ED%) is other than 30%, i.e. the jack is running more than 18 minutes per hour (18/60=30%), the Running power ( $P_d$ ) must be adjusted accordingly. Please note  $P_d < P_{ED}$ ; Running power ( $P_d$ ) must be lower than the Thermal power ( $P_{ED}$ ).

In cases where Intermittence factor, ED is other than 30%/hour, the running power ( $P_d$ ) is to be adjusted according to diagram which is calculated by following formula:

$$P_{ED} = \frac{30\%}{ED\%} \times P_{max}$$

ED% = Intermittence per hour

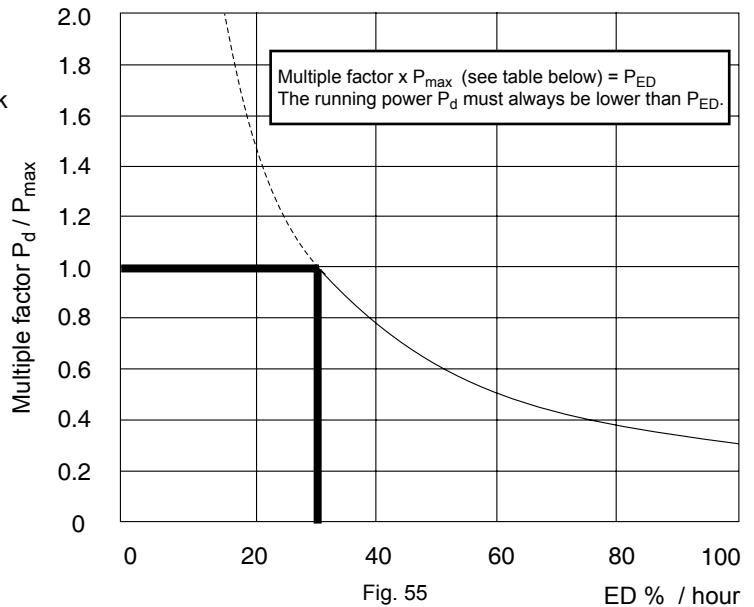

### CRITICAL TRAVELLING NUT SPEED

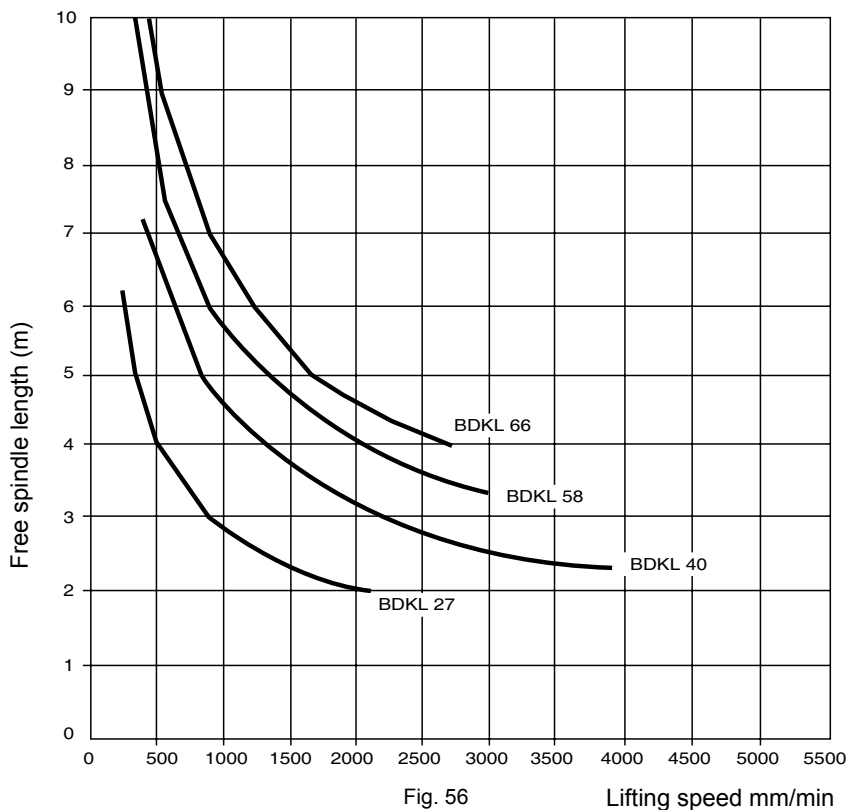

### Max Permissible Speed V mm/min With Grease Lubrication

BDK / BDKL	Ratio L
27	2100
40	3900
58	3000
66	2700

# SERIES BD

## LIFETIME OF BALL SCREWS

The nominal lifetime is reached by 90% of the ball screws before the running surfaces show any sign of fatigue. 50% of the ball screws reach a lifetime which is 5 times their nominal lifetime.

### Lifetime In Running Metres X 10<sup>3</sup>

Size	Max load (kN)	100% of max load (kN)	75% of max load (kN)	50% of max load (kN)
27	8	15.6	37.1	125.1
40	25	5.8	13.7	46.1
58	50	10.8	25.6	86.4
66	125	1.5	3.5	11.8

# SERIES BD

## DIMENSIONS BDK 27-66

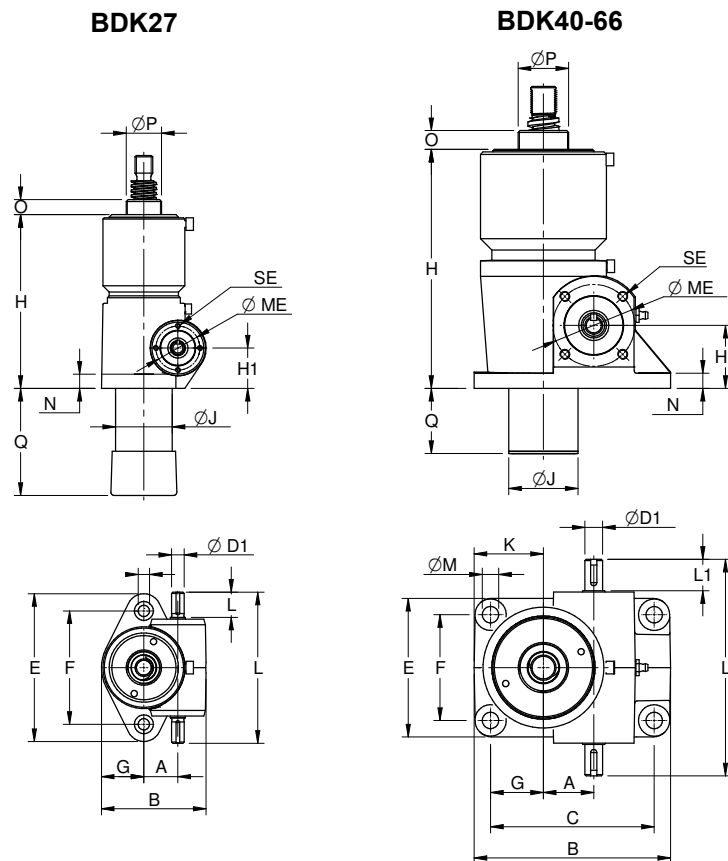

Fig. 57

Keyway DIN 6885

Size	27	40	58	66
A	27	40	58	66
B	82	156	196	222
C	-	130	158	178
Ø D1j6	10	14	19	24
E	115	110	170	190
F	90	84	134	146
G	32.5	42	40	51
H	135	190	265	318
H1	32	50	55	68
Ø J - Aluminium	45	55	70	78
Ø J - Steel	32	45	55	75
K	-	55	60	73
L	120	172	237	268
L1	20	25	35	40
Ø M	9	13	18	21
N	10	12	12	16
O	12	15	15	15
Ø P	28	40	50	70
Q-Aluminium	30 + Stroke	30 + Stroke	47 + Stroke	47 + Stroke
Q-Steel	30 + Stroke	35 + Stroke	35 + Stroke	35 + Stroke
SE	M4 x 8	M8 x 12	M8 x 12	M8 x 12
ME	35	65	80	80

# SERIES BD

## DIMENSIONS BDK 27-66 END EXECUTION 1, 2, 3

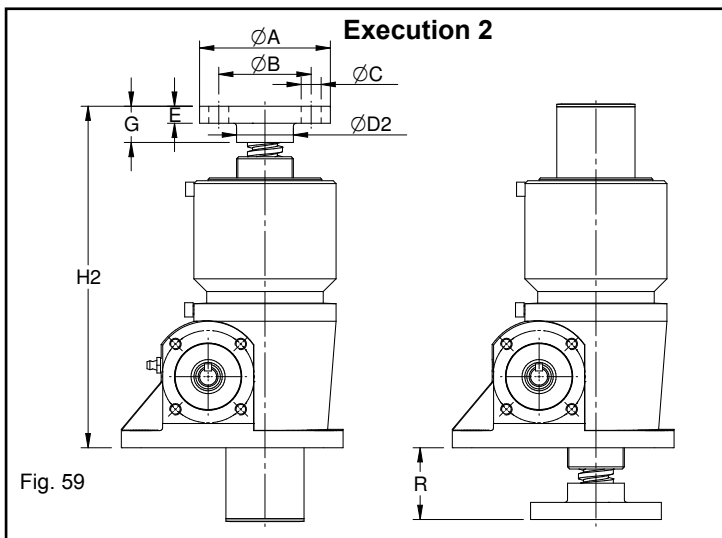
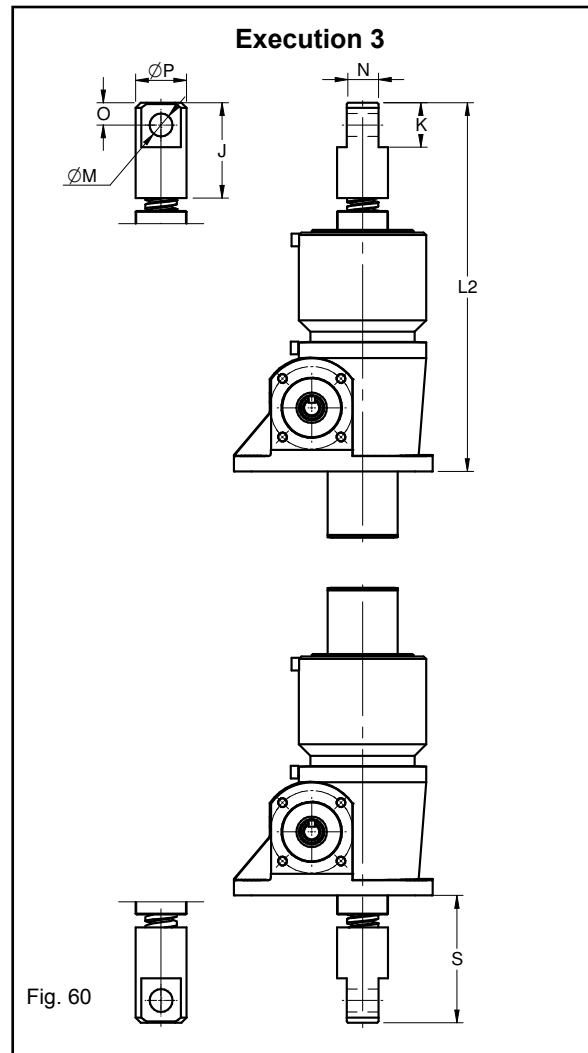
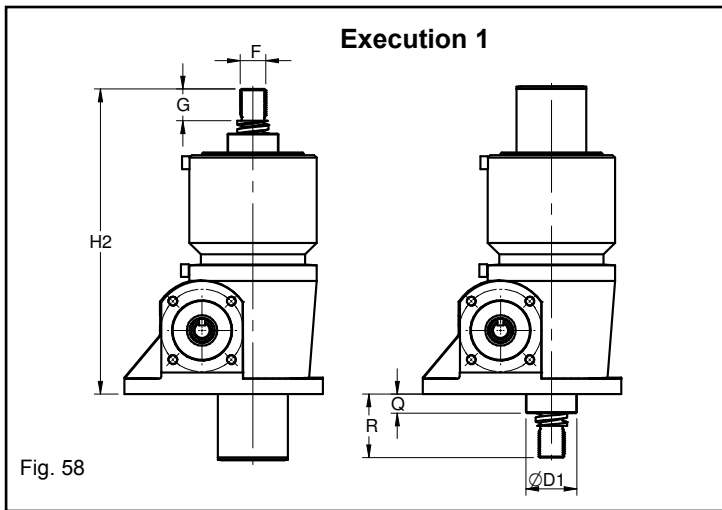

Size	27	40	58	66
Ø A	65	92	122	150
Ø B	50	65	90	110
Ø C	4x7	4x14	4x18	4x 21
Ø D1	28	40	50	70
Ø D2	30	40	55	70
E	8	12	16	20
F	M14x2	M20x1.5	M30x2	M40x3
G	20	25	36	50
H2	172	235	321	388
J	55	75	100	125
K	25	35	50	60
L2	207	285	385	463
Ø M H11	12	18	25	30
N	20	25	35	45
O	12.5	17.5	25	30
Ø P	30	40	55	70
Q	12	15	15	15
R	37	45	56	70
S	72	95	120	145

# SERIES BD

## DIMENSIONS WITH BELLOWS

### BDK 27-66

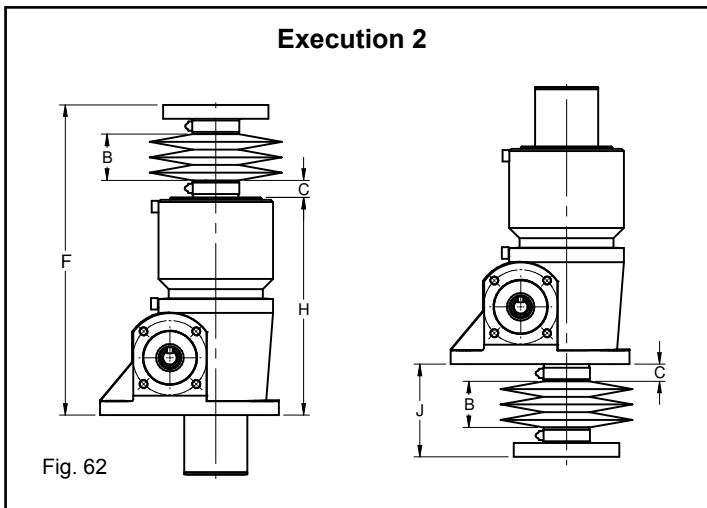
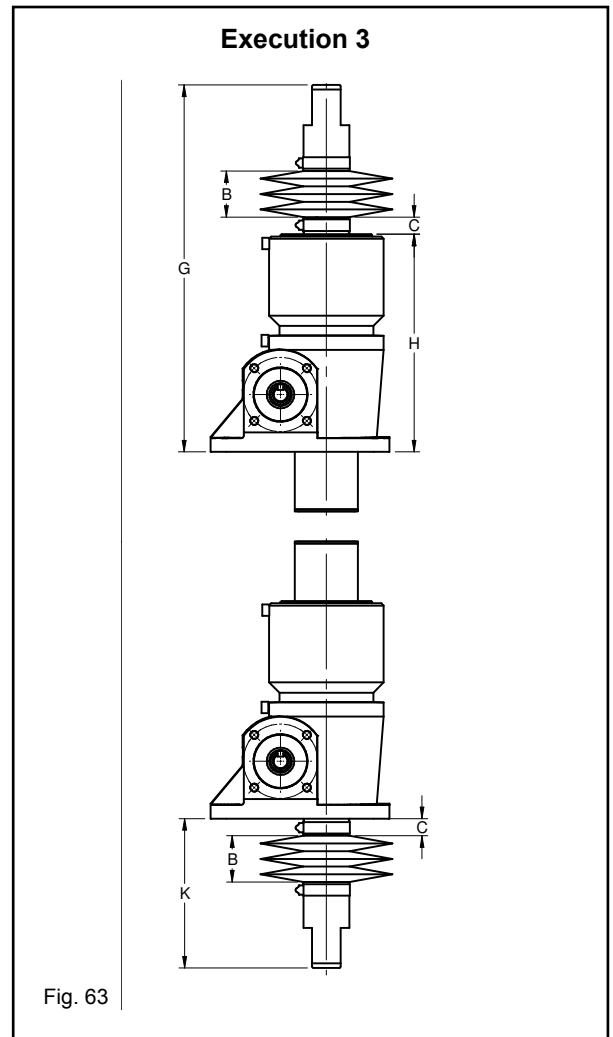
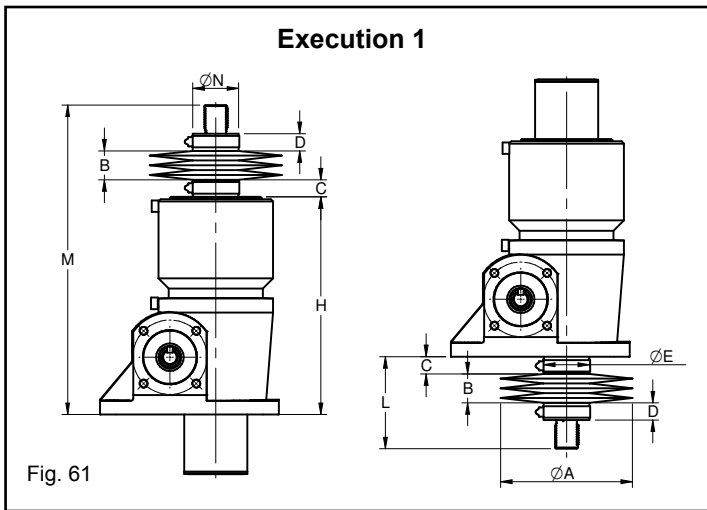

Size	27	40	58	66
Ø A	95	115	130	150
B	0.05 x Stroke**			
C	12	15	15	15
D	15	15	15	15
E*	28	40	50	70
F	172 + B	235 + B	321 + B	388 + B
G	207 + B	285 + B	385 + B	463 + B
H	135	190	265	318
J	37 + B	45 + B	56 + B	70 + B
K	72 + B	95 + B	120 + B	145 + B
L	52 + B	60 + B	71 + B	85 + B
M	187 + B	250 + B	336 + B	403 + B
N	30	40	55	70

\*Hole for hose clamp Ø E + 30

\*\* Minimum B dimension will be 5 mm (i.e. when Stroke is below 100mm)

# SERIES BD

## DIMENSIONS BDKL 27-66

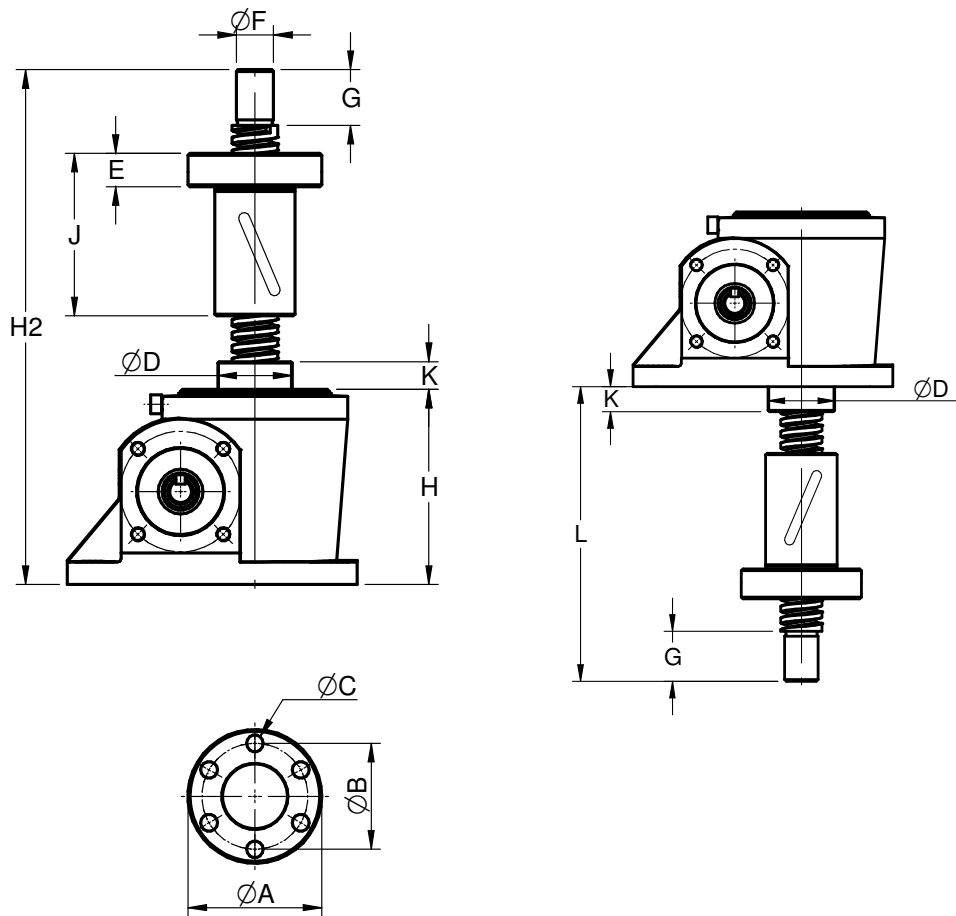

Fig. 64

Size	27	40	58	66
$\varnothing A$	83	72	117	137
$\varnothing B$	70	57	91	108
$\varnothing C$	4 x 7	6 x 9	8 x 18	8 x 18
$\varnothing D$	28	40	50	70
E	17	18	28	30
$\varnothing F$ h7	12	20	30	40
G	20	30	40	60
H	70	105	130	157
H2	185 + Stroke	250 + Stroke	340 + Stroke	420 + Stroke
J	57	88	114	136
K	12	15	15	15
L	121 + Stroke	150 + Stroke	230 + Stroke	284 + Stroke



# SERIES BD

## IEC MOTORFLANGE

BD100 - BD200 consult application engineers.

Size	Motor size	Ø A		B	C		Ø H		Ø K		Ø P	Q		R	SE	ME	NE	D	E	F	G
		B14	B5		B14	B5	B14	B5	B14	B5		B14	B5								
BD27	63	90	-		100.5	-	75		60		11	6		3.5					23	17.5	62
BD27	71	105	-	60	111.5	-	85		70		14	7		4	M4x8	35	28	38.5	30	21.5	73
BD40	63	92	140		112	112	75	115	60	95	11	6	6	3.5					23	3	52
BD40	71	102	160	86	118	118	85	130	70	110	14	7	7	4	M8x12	65	47	60	30	2	58
BD40	80	118	200		128	128	100	165	80	130	19	7	11.5	4					40	2	68
BD40	90	140	200		138	138	115	165	95	130	24	9	11.5	4					50	2	78
BD58	71	108	160		151	151	85	130	70	110	14	7	7	4					30	2.5	69
BD58	80	118	200		161	171	100	165	80	130	19	7	11.5	4					40	2.5/12.5	89
BD58	90	140	200	118.5	171	171	115	165	95	130	24	9	11.5	4	M8x12	80	62	82	50	2.5	89
BD58	100/112	160	250		181.5	181.5	130	215	110	180	28	9	14	5					60	3	99.5
BD66	71	108	160		171	171	85	130	70	110	14	7	7	4					30	7	79
BD66	80	118	200	134	181	191	100	165	80	130	19	7	11.5	4	M8x12	80	62	92	40	7	89
BD66	90	140	200		191	191	115	165	95	130	24	9	11.5	4					50	7	99
BD66	100/112	160	250		201.5	201.5	130	215	110	180	28	9	14	5					60	7.5	109
BD86	80	118	200		209	219	100	165	80	130	19	7	11.5	4					40	20	99
BD86	90	140	200	159	219	219	115	165	95	130	24	9		4	M10	72	88	110	50	10	109
BD86	100/112	160	250		229	229	130	215	110	180	28	9	14	5	x15				60	10	119
BD86	132	-	300		-	254	-	265	-	230	38	-	14	5					80	15	144

Bigger screw jack sizes with motorflanges are available on request.

All IEC Motors are accepted. Other Motor connections are available on request.

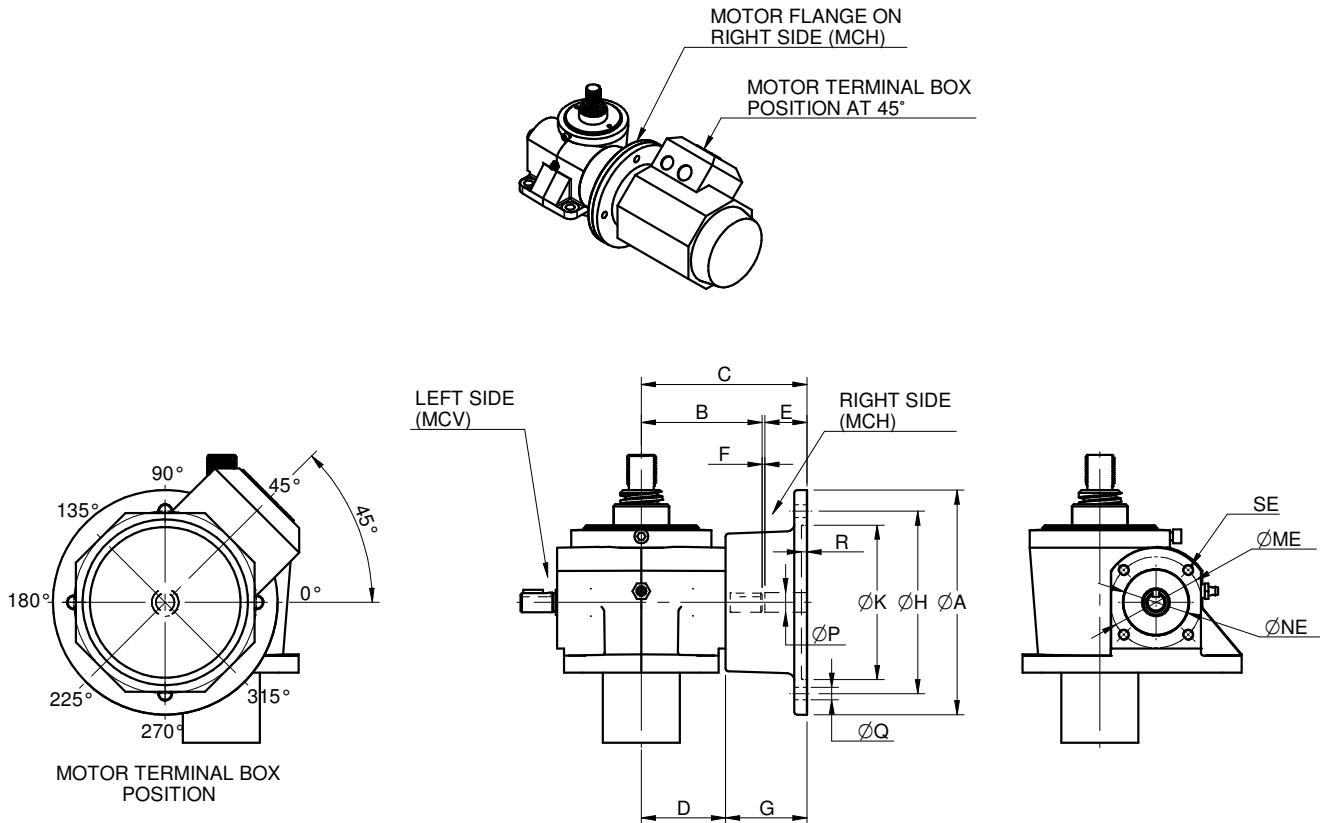

Fig. 65

# SERIES BD

## TRUNNION

### Trunnion

#### Single Trunnion

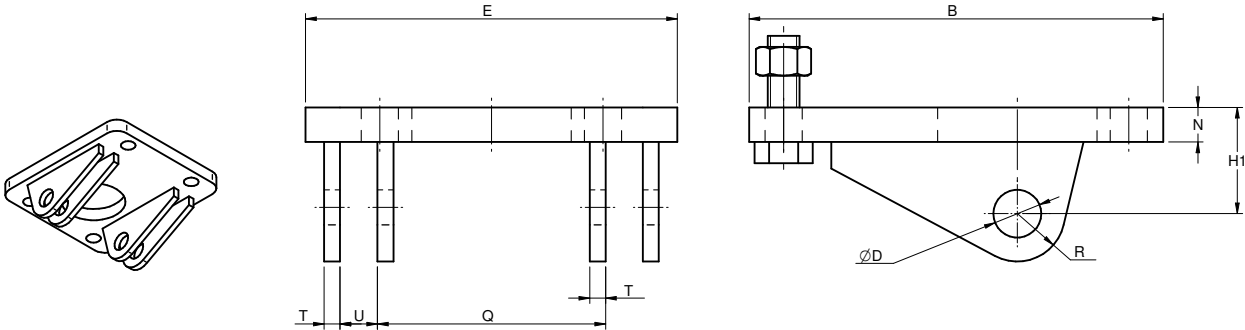

Fig. 66

#### Double Trunnion

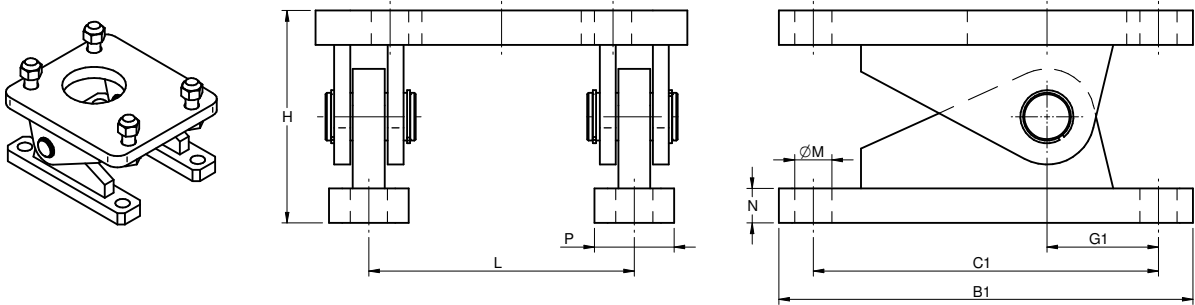

Fig. 67

Size	B	B1	C1	D	E	G1	H	H1	L	M	N	P	Q	R	T	U
40	156	156	130	18H7	140	42	80	40	100	14	13	30	86	18	6	14
58	196	205	165	25H7	170	47	105	52.5	125	18	16	35	108	25	8	17
66	222	234	190	35H7	250	63	150	75	170	22	22	70	138	35	15	32
86	300	300	250	40H7	300	85	170	85	210	26	28	70	173	40	18	37
100	350	350	280	50H7	350	95	205	102.5	250	33	34	80	208	50	20	42
125	460	460	380	65H7	440	140	260	130	320	39	47	90	268	65	25	52

## COMBINATION SCREW JACK WITH OTHER PRODUCTS

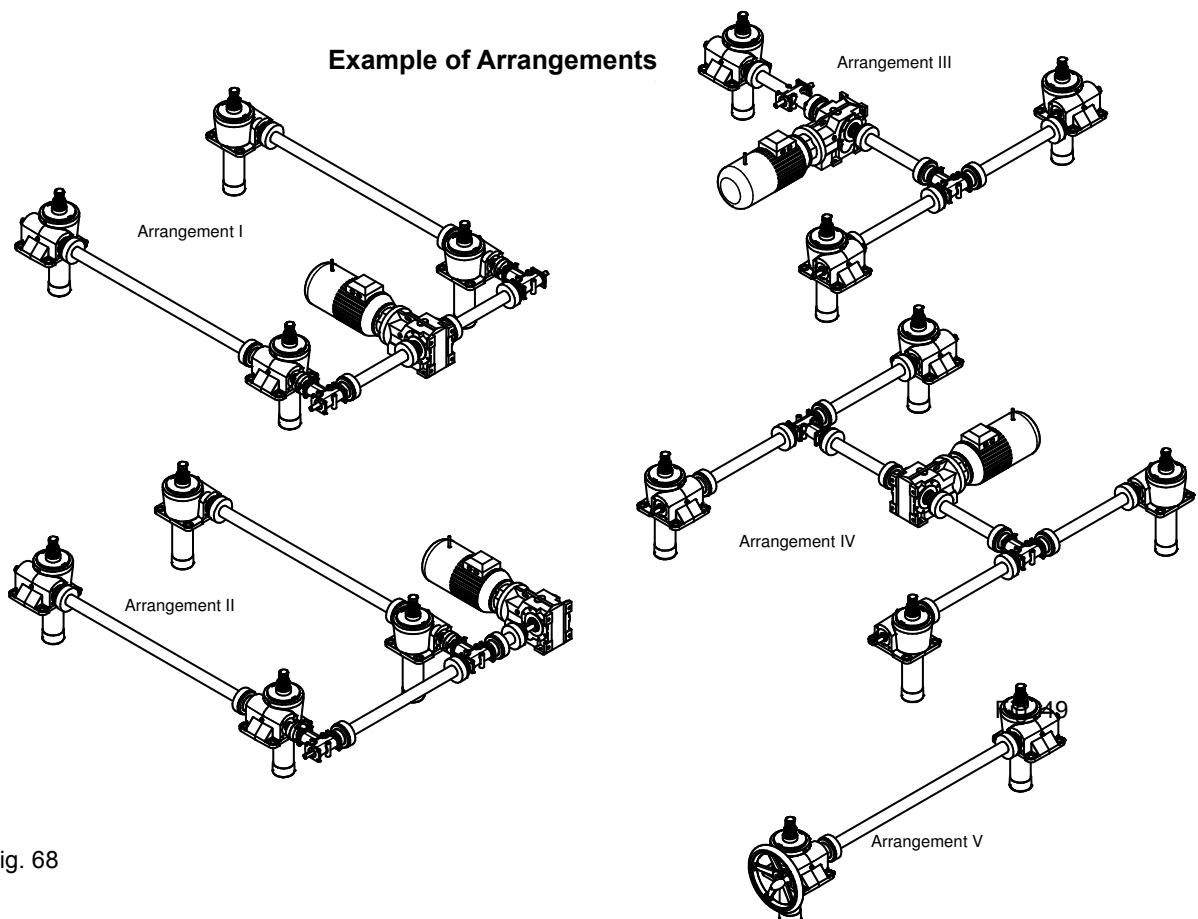
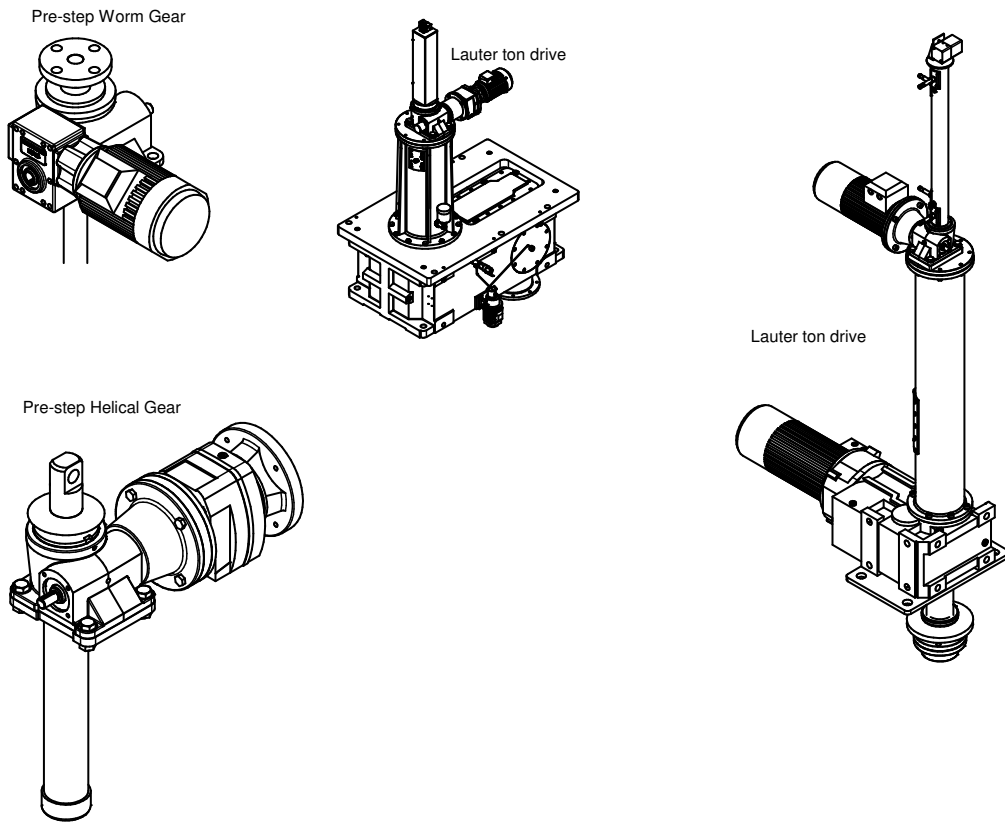

Fig. 68

## UNIVERSAL JOINT SHAFT

### Type X-G

Universal joint shafts for spanning any distance and for compensating for larger radial offset misalignments. The element type X is torsionally very stiff, free from play, but has bending elasticity and is axially and angularly flexible.

Moreover, it is oil-resistant and withstands temperatures up to 150° C.

### Selection of Universal Joint Shafts:

Torque capacity is in accordance with the table below. Permissible angular misalignment is as shown in table and diagram below.

The maximum permissible length for the centre part is dependant on the speed and can be found from diagram on page 48.

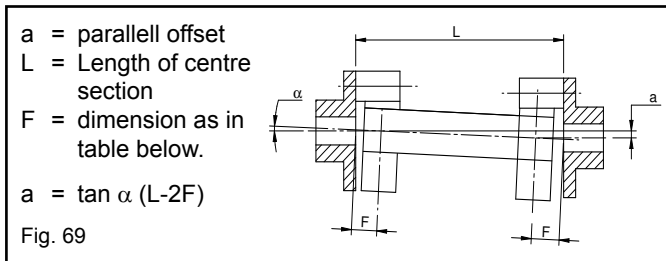

### Permissible Shaft Misalignment

Types	Angular Degree	Parallel Offset mm (a)	Axial mm
X-G	1°	$\tan \alpha (L-2F)$	±1

\* Applies for 1500 RPM, for other speeds refer to diagram below.

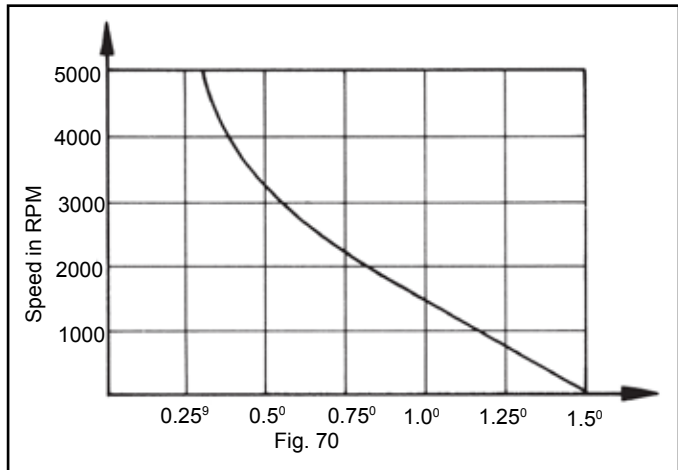

### Dimensions

Size	A	B	d <sub>1</sub> max	d <sub>2</sub>	d <sub>3</sub>	F	L1	M	N1	R	TK/Division
1 X	18	7	25	56	57	12	24	M6	36	30	44/2x180°
2 X	24	8	38	85	88	14	28	M8	55	40	68/2x180°
4 X	25	8	45	100	100	14,5	30	M8	65	45	80/3x120°
8 X	30	10	55	120	125	17	42	M10	80	60	100/3x120°
16 X	35	12	70	150	155	21	50	M12	100	70	125/3x120°
25 X	40	14	85	170	175	23	55	M14	115	85	140/3x120°
30 X	50	16	100	200	205	30	66	M16	140	100	165/3x120°

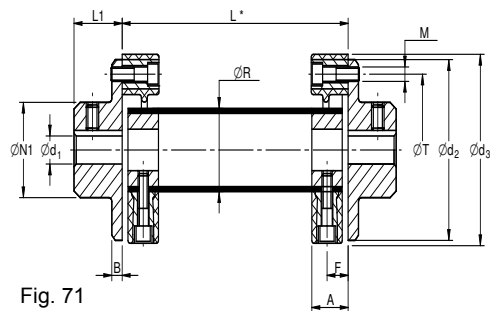

\* Dimension L stands for any non standard lengths. Always state the required dimension in enquiries and orders.

### Sizes

The shafts are available in 7 sizes for nominal torques from 10 to 550 Nm with a single element or up to 1100 Nm with two elements connected in tandem.

Coupling selection should always be based on nominal torque rating.

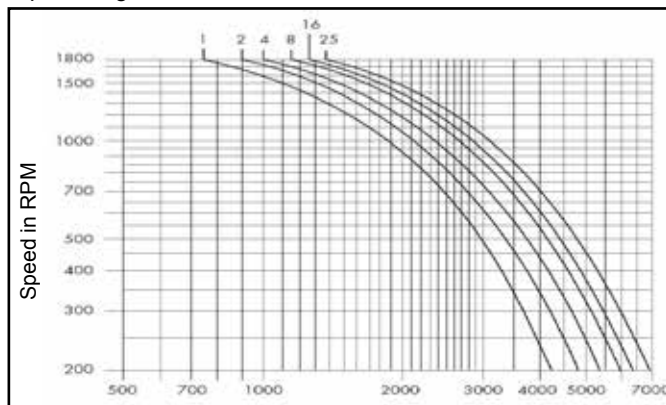

### Permissible Torques and Speeds

Size	Nominal torque TkN Nm	Max torque Tkmax Nm
1	10	25
2	30	60
4	60	120
8	120	280
16	240	560
25	370	800
30	550	1400

# SERIES BD

## BEVEL GEARS

We recommend two types of bevel gears to be used in screw jack arrangement.

### 1. DZ-Range

For smaller loads and lower speeds we recommend the DZ-range.

- Sand cast aluminium housing
- Hardened, straight bevel gears, ratio 1:1 or 2:1
- DZ1: Lubricated for life with grease.
- DZ2-3-4: Lubricated with oil to be changed every 1000 hour.
- All mounting positions possible.
- Lifetime approx 2 000 hours
- Operating temperature -20°C to +80°C

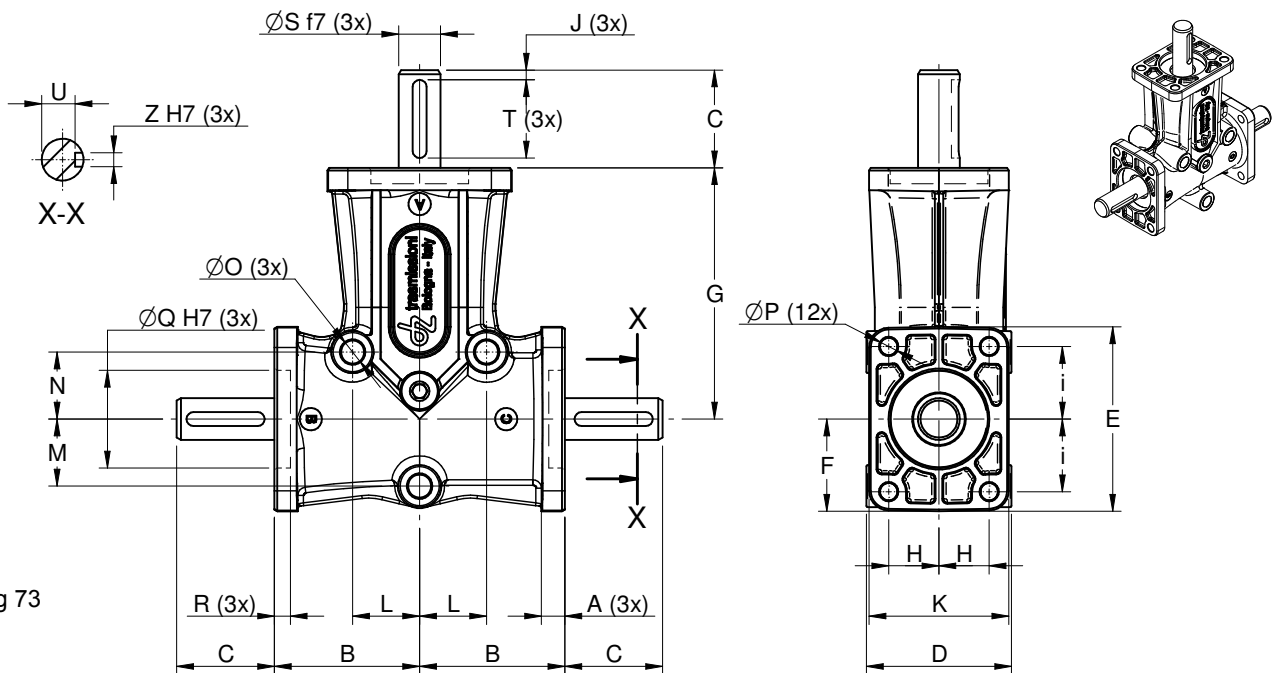

Fig 73

Type	A	B	C	D	E	F	G	H	i	J	K	L	M	N	O	P	Q	R	S	T	U	Z	Wt (kg)
DZ 1	6	34	15	33	40	20	60	11	15	-	32	16	16	16	5.2	4.2	22	2.5	8	-	-	-	0.3
DZ 2	8	52	35	52	66	33	90	18	26	3.5	50	24	24	24	8.3	6.2	35	5.7	15	28	12	5	1.2
DZ 3	10	75	50	76	96	48	140	27	38	5	74	38	38	38	8.3	8.3	55	7.5	20	40	16.5	6	3.5
DZ 4	13	88	70	100	98	49	150	38	38	10	98	45	45	70	10.5	10.3	65	3.5	25	50	21	8	5.8

### Power Ratings

Output speed n2 rpm	Ratio	Input speed n1 rpm	DZ1		DZ2		DZ3		DZ4	
			Input power P1 kW	Output torque T2 Nm	Input power P1 kW	Output torque T2 Nm	Input power P1 kW	Output torque T2 Nm	Input power P1 kW	Output torque T2 Nm
50	1:1	50	0.02	4.7	0.09	16.5	0.28	53.1	0.46	87.3
50	2:1	100	0.02	4.0	0.08	14.6	0.22	42.5	0.43	82.3
100	1:1	100	0.04	3.9	0.15	13.9	0.47	44.6	0.77	73.4
100	2:1	200	0.04	3.4	0.13	12.3	0.37	35.7	0.72	69.2
200	1:1	200	0.07	3.3	0.24	11.7	0.79	37.5	1.29	61.8
200	2:1	400	0.06	2.8	0.22	10.3	0.63	30.1	1.22	58.2
400	1:1	400	0.12	2.8	0.41	9.8	1.32	31.6	2.17	51.9
400	2:1	800	0.10	2.4	0.36	8.7	1.06	25.3	2.05	48.9
800	1:1	800	0.19	2.3	0.69	8.2	2.22	26.5	3.66	43.7
800	2:1	1600	0.10	2.4	0.61	7.3	1.78	21.3	3.44	41.1
1400	1:1	1400	0.30	2.0	1.05	7.2	3.38	23.1	5.56	38.0
1400	2:1	2800	0.26	1.7	0.93	6.3	2.71	18.5	5.24	35.8
2000	1:1	2000	0.39	1.8	1.37	6.6	4.42	21.1	7.27	34.7
3000	1:1	3000	0.53	1.7	1.86	5.9	5.99	19.1	9.86	31.4

# SERIES BD

## BEVEL GEARS

### 2. BG-range

For larger loads and higher speeds we recommend the BG-range.

- Cast Iron housing
- Case Hardened, spiral bevel gears, ratio 1:1 or 2:1
- Lubricated with grease for input speed up to 1000rpm.  
Lubricated with oil for speeds higher than 1000 rpm.
- All mounting positions possible.
- Lifetime approx 20000 hours
- Operating temperature - 20°C to +80°C

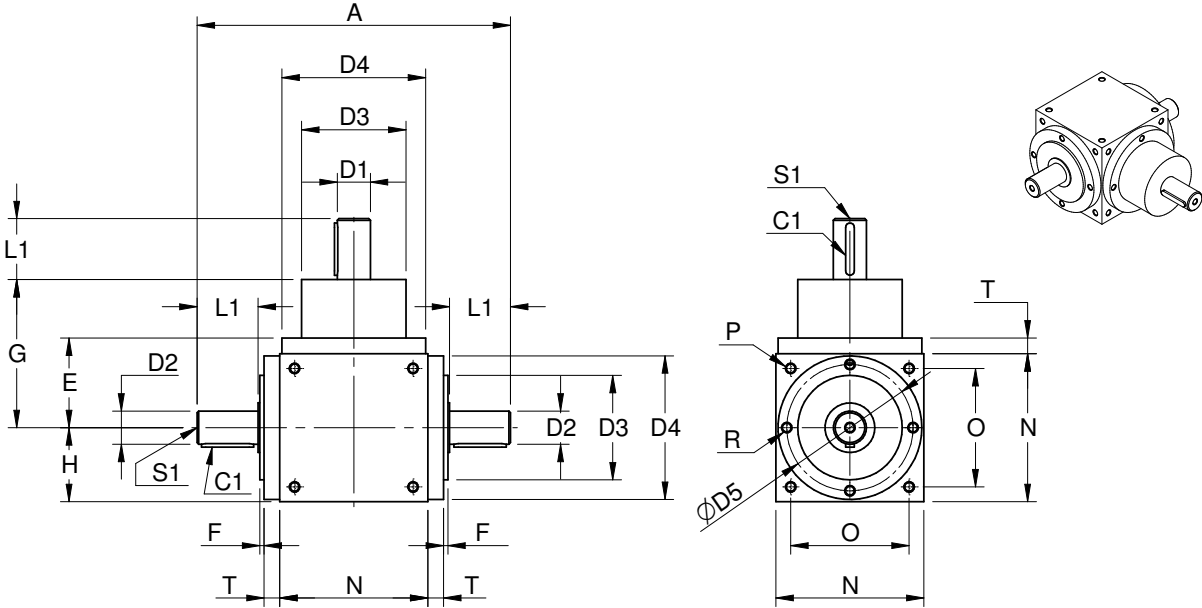

Fig 74

Type	A	B	C	C1	D2	D3	D4	D5	E	F	G	H	L1	M	N	O	P	R	S1	T	Wt(kg)
<b>BG19</b>	210	105	65	35x6x6	19	60	86	72	59	4	100	45	40	140	90	70	M6	M6	M6x12	14	6
<b>BG24</b>	260	130	80	40x8x7	24	70	105	88	73	5	115	55	50	165	110	88	M8	M8	M8x16	18	12
<b>BG32</b>	310	155	95	50x10x8	32	95	135	115	88	5	145	70	60	205	140	110	M10	M10	M10x20	18	22
<b>BG38</b>	360	180	110	60x10x8	38	120	165	145	103	5	170	85	70	240	170	136	M12	M12	M12x24	18	37
<b>BG42</b>	410	205	15	70x12x8	42	135	190	165	118	5	195	100	80	275	200	155	M12	M12	M12x24	18	57
<b>BG55</b>	520	260	150	100x16x10	55	170	230	205	143	5	245	120	110	355	240	190	M14	M14	M14x28	23	87

# SERIES BD

## BEVEL GEARS

### Nominal Power Rating P<sub>n</sub> -

P<sub>n</sub> is the nominal power calculated for a life of 20000 hours with service factor K<sub>a</sub> = 1.

Output speed n2 rpm	Ratio	Input speed n1 rpm	BG19		BG24		BG32		BG38	
			Input power P1 kW	Output torque T2 Nm	Input power P1 kW	Output torque T2 Nm	Input power P1 kW	Output torque T2 Nm	Input power P1 kW	Output torque T2 Nm
10	1:1	10	0.07	64.6	0.09	79.5	0.2	180.5	0.4	367
5	2:1	10	0.03	49.7	0.03	59.5	0.1	124.8	0.13	239
50	1:1	50	0.35	63.7	0.42	77	0.9	174.7	1.9	355.5
25	2:1	50	0.13	49.3	0.16	59.1	0.3	122.9	0.6	234
100	1:1	100	0.69	62.9	0.82	75.3	1.9	170.9	3.8	349
50	2:1	100	0.27	48.8	0.32	58.9	0.6	119	1.3	231
400	1:1	400	2.62	60	8.08	70.6	7	160.3	14.5	331
200	2:1	400	1.02	46.7	1.28	58.6	2.5	115.2	4.8	222
600	1:1	600	3.85	58.8	4.51	68.9	10.2	156.5	21.1	323
300	2:1	600	1.51	46.1	1.89	57.8	3.7	113.3	7.1	218
800	1:1	800	5.07	58.1	5.86	67.2	13.3	152.6	27.6	316.5
400	2:1	800	1.99	45.7	2.5	57.2	4.9	111.4	9.4	215
1000	1:1	1000	6.26	57.4	7.19	66	16.3	149.8	33.8	310
500	2:1	1000	2.46	45.1	3.09	56.6	6	109.4	11.6	212
1500	1:1	1500	9.17	56.1	10.37	63.4	23.6	144	49.4	302
750	2:1	1500	3.6	42.6	4.55	55.7	8.8	107.5	16.9	206
2000	1:1	2000	11.94	53.3	13.38	61.3	30.4	139.2	64.1	294
1000	2:1	2000	4.73	43.4	5.99	54.9	11.5	105.6	22	201
2800	1:1	2800	16.27	54.7	17.88	58.6	40.8	133.4	87.2	285.6
1400	2:1	2800	6.51	44	8.15	53.4	15.5	101.8	29.9	196

Output speed n2 rpm	Ratio	Input speed n1 rpm	BG42		BG55	
			Input power P1 kW	Output torque T2 Nm	Input power P1 kW	Output torque T2 Nm
10	1:1	10	0.5	432	1	941
5	2:1	10	0.15	281	0.35	643
50	1:1	50	2.3	420	5	912
25	2:1	50	0.75	278	1.7	632
100	1:1	100	4.5	411	9.7	893
50	2:1	100	1.5	272	3.4	618
400	1:1	400	17	390	36.6	840
200	2:1	400	5.7	261	12.9	591
600	1:1	600	24.9	380	53	810
300	2:1	600	8.4	257	18.8	576
800	1:1	800	32.5	372	70	800
400	2:1	800	11	253	24.8	568
1000	1:1	1000	39.8	365	86	787
500	2:1	1000	13.6	249	30.6	561
1500	1:1	1500	58.1	355	125	763
750	2:1	1500	19.8	243	44.4	543
2000	1:1	2000	75.4	346	-	-
1000	2:1	2000	25.8	237	-	-
2800	1:1	2800	102.6	336	-	-
1400	2:1	2800	35.2	230	-	-

# SERIES BD

## TELESCOPIC SPRING PROTECTION

- Made of high quality hardened spring steel to dimension shown down
- Very good sealing effect between the coils
- Available also in stainless steel

Di = inside diam ±1

Da = outside diam ±2

DF1 = outside diam of centering flange (Di - 2 mm)

DF2 = inside diam of flange socket (Da + 4 mm)

L<sub>min</sub> = min installation length

L<sub>max</sub> = max installation length

### IMPORTANT

When ordering state vertical or horizontal position.

Type	Size	Di	Da	Lmin	Lh max	Lv max	T	D
<b>BD 27</b>								
SF	25-200-20	25	40	20	160	200	12	50
SF	25-350-30	25	45	30	290	350	12	55
SF	25-500-40	25	49	40	420	500	12	59
SF	25-650-50	25	45	50	590	650	12	55
<b>BD40</b>								
SF	35-300-30	35	55	30	240	300	15	65
SF	35-450-40	35	58	40	390	450	15	68
SF	35-650-50	35	60	50	590	650	15	70
SF	35-850-60	35	65	60	790	850	15	75
<b>BD58</b>								
SF	45-250-30	45	61	30	190	250	15	71
SF	45-450-40	45	69	40	390	450	15	79
SF	45-650-50	45	75	50	550	650	15	85
SF	45-1100-75	45	84	75	950	1100	15	94
SF	45-1600-100	45	87	100	1400	1600	15	97
SF	45-2200-120	45	100	120	-	2200	15	110
<b>BD66</b>								
SF	60-250-30	60	78	30	190	250	15	88
SF	60-450-50	60	82	50	350	450	15	92
SF	60-800-60	60	96	60	680	800	15	106
SF	60-1100-75	60	102	75	950	1100	15	112
SF	60-1800-100	60	109	100	1600	1800	15	119
SF	60-2100-120	60	108	120	1860	2100	15	118
<b>BD86</b>								
SF	70-250-30	70	93	30	190	250	15	103
SF	70-550-50	70	97	50	450	550	15	107
SF	70-750-60	70	102	60	630	750	15	112
SF	70-1100-75	70	113	75	900	1100	15	123
SF	70-1800-100	70	124	100	1700	1800	15	134
SF	70-2400-120	70	136	120	2200	2400	15	146
SF	70-3250-180	70	152	180	2500	3250	15	162
<b>BD100</b>								
SF	100-350-60	100	126	60	230	350	15	136
SF	100-600-75	100	129	75	450	600	15	139
SF	100-1000-100	100	132	100	800	1000	15	142
SF	100-1300-120	100	136	120	1060	1300	15	146
SF	100-2000-150	100	100	150	1700	2000	15	110
SF	100-3000-150	100	100	150	-	3000	15	110

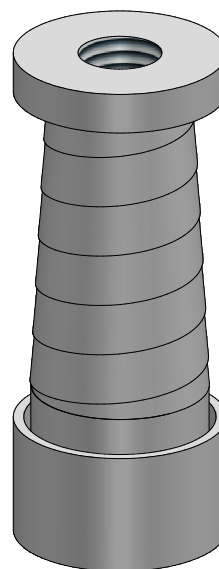
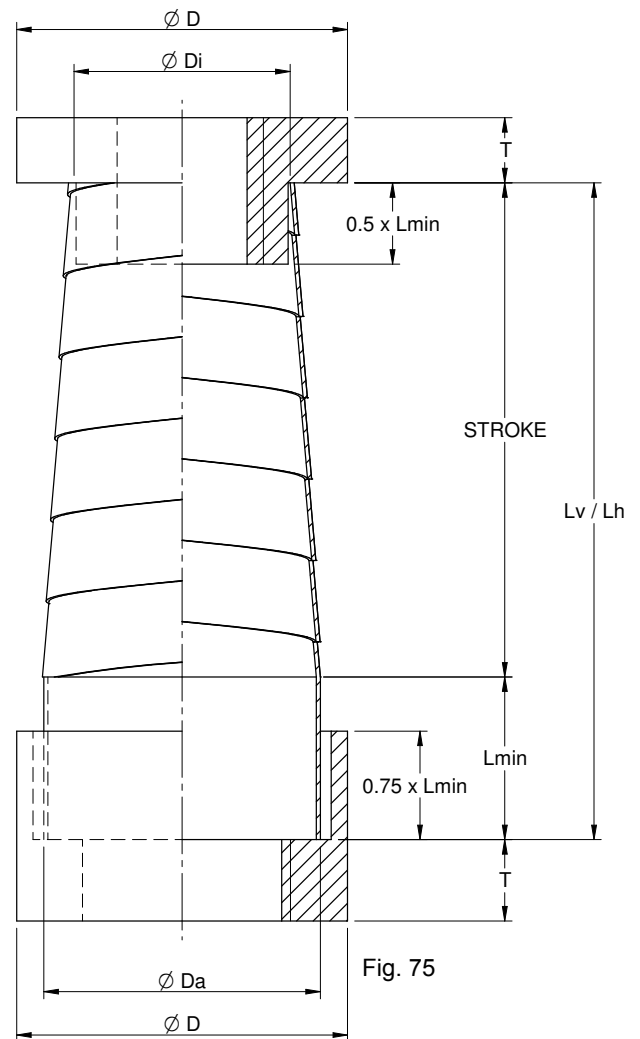

Fig. 76

\* - Available in Steel only,  
Other dimensions available on request.



# SERIES BD

## LUBRICATION OF SCREW JACKS

### Type of Grease

1. At ambient temperature -30° to +30° C
BP Energrease LS-EP2
Castrol Spheerol EPL2
Esso Beacon EP2
Gulf Gulflex MP
Mobil Mobilux EP2
Shell Alvania EP Grease 2 alt Retinax A
SKF Alfalub LGEP2
Texaco Mulfifak EP2

II. At ambient temperature -45°C to -30°C  
Mobil Mobilgrease 28

III. At ambient temperature +30°C to +60°C  
Mobil Mobiltemp SHC100  
Sealrings in viton are recommended.

### Lubrication intervals

Normal duty < 1 000 mm/min lifting speed:  
Every 30 hours of duty

Arduous duty > 1 000 mm/min lifting speed:  
Every 10 hours of duty

**Renew grease every 400 hours of duty.**

Note: On screw jack type BDL and BDKL the lifting screw shall always be lubricated with a thin film of grease.

Approved lubrication manual and Installation & Maintenance manual, please visit our website ([www.benzlers.com](http://www.benzlers.com))

### Screw Jack Body Grease Quantity

Type	Grease quantity
BD/BDL/BDKL 27	0.3 kg
BD/BDL/BDKL 40	0.5 kg
BD/BDL/BDKL 58	0.9 kg
BD/BDL/BDKL 66	1.2 kg
BD/BDL86	1.4 kg
BD/BDL100	2.5 kg
BD/BDL125	5.2 kg
BD/BDL200	15 kg
BDK27	0.4 kg
BDK40	0.7 kg
BDK58	1.7 kg
BDK66	2.0 kg

### IMPORTANT

#### Product Safety Information

**General** - The following information is important in ensuring safety. It must be brought to the attention of personnel involved in the selection of power transmission equipment, those responsible for the design of the machinery in which it is to be incorporated and those involved in its installation, use and maintenance.

Our equipment will operate safely provided it is selected, installed, used and maintained properly. As with any power transmission equipment proper precautions must be taken as indicated in the following paragraphs, to ensure safety.

**Potential Hazards** - these are not necessarily listed in any order of severity as the degree of danger varies in individual circumstances. It is important therefore that the list is studied in its entirety:-

- 1) Fire/Explosion
  - (a) Oil mists and vapour are generated within gear units. It is therefore dangerous to use naked lights in the proximity of gearbox openings, due to the risk of fire or explosion.
  - (b) In the event of fire or serious overheating (over 300 oC), certain materials (rubber, plastics, etc.) may decompose and produce fumes. Care should be taken to avoid exposure to the fumes, and the remains of burned or overheated plastic/rubber materials should be handled with rubber gloves.
- 2) Guards - Rotating shafts and couplings must be guarded to eliminate the possibility of physical contact or entanglement of clothing. It should be of rigid construction and firmly secured.
- 3) Noise - High speed gearboxes and gearbox driven machinery may produce noise levels which are damaging to the hearing with prolonged exposure. Ear defenders should be provided for personnel in these circumstances. Reference should be made to the Department of Employment Code of Practice for reducing exposure of employed persons to noise.
- 4) Lifting - Where provided (on larger units) only the lifting points or eyebolts must be used for lifting operations (see maintenance manual or general arrangement drawing for lifting point positions). Failure to use the lifting points provided may result in personal injury and/or damage to the product or surrounding equipment. Keep clear of raised equipment.
- 5) Lubricants and Lubrication
  - (a) Prolonged contact with lubricants can be detrimental to the skin. The manufacturer's instruction must be followed when handling lubricants.
  - (b) The lubrication status of the equipment must be checked before commissioning. Read and carry out all instructions on the lubricant plate and in the installation and maintenance literature. Heed all warning tags. Failure to do so could result in mechanical damage and in extreme cases risk of injury to personnel.
- 6) Electrical Equipment - Observe hazard warnings on electrical equipment and isolate power before working on the gearbox or associated equipment, in order to prevent the machinery being started.
- 7) Installation, Maintenance and Storage
  - (a) In the event that equipment is to be held in storage, for a period exceeding 6 months, prior to installation or commissioning, we must be consulted regarding special preservation requirements. Unless otherwise agreed, equipment must be stored in a building protected from extremes of temperature and humidity to prevent deterioration.  
The rotating components (gears and shafts) must be turned a few revolutions once a month (to prevent bearings brinelling).
  - (b) External gearbox components may be supplied with preservative materials applied, in the form of a "waxed" tape overwrap or wax film preservative. Gloves should be worn when removing these materials. The former can be removed manually, the latter using white spirit as a solvent.  
Preservatives applied to the internal parts of the gear units do not require removal prior to operation.
  - (c) Installation must be performed in accordance with the manufacturer's instructions and be undertaken by suitably qualified personnel.
  - (d) Before working on a gearbox or associated equipment, ensure that the load has been removed from the system to eliminate the possibility of any movement of the machinery and isolate power supply. Where necessary, provide mechanical means to ensure the machinery cannot move or rotate. Ensure removal of such devices after work is complete.
  - (e) Ensure the proper maintenance of gearboxes in operation. Use only the correct tools and our approved spare parts for repair and maintenance. Consult the Maintenance Manual before dismantling or performing maintenance work.
- 8) Hot Surfaces and Lubricants
  - (a) During operation, gear units may become sufficiently hot to cause skin burns. Care must be taken to avoid accidental contact.
  - (b) After extended running the lubricant in gear units and lubrication systems may reach temperatures sufficient to cause burns. Allow equipment to cool before servicing or performing adjustments.
- 9) Selection and Design
  - (a) Where gear units provide a backstop facility, ensure that back-up systems are provided if failure of the backstop device would endanger personnel or result in damage.
  - (b) The driving and driven equipment must be correctly selected to ensure that the complete machinery installation will perform satisfactorily, avoiding system critical speeds, system torsional vibration, etc.
  - (c) The equipment must not be operated in an environment or at speeds, powers, torques or with external loads beyond those for which it was designed.
  - (d) As improvements in design are being made continually the contents of this catalogue are not to be regarded as binding in detail, and drawings and capacities are subject to alterations without notice.

The above guidance is based on the current state of knowledge and our best assessment of the potential hazards in the operation of the gear units.

Any further information or clarification required may be obtained by contacting our Application Engineers.



# CONTACT US

## AUSTRALIA

### **Radicon Transmission (Australia) PTY Ltd**

Australia  
Tel: +61 421 822 315

## EUROPE

### **Benzler TBA BV** Jachthavenweg 2 NL-5928 NT Venlo

Germany  
Tel: 0800 350 40 00  
Fax: 0800 350 40 01

Italy  
Tel: +39 02 824 3511

Netherlands & the rest of Europe  
Tel: +31 77 324 59 00  
Fax: +31 77 324 59 01

## INDIA

### **Elecon. Engineering Company Ltd.**

Anand Sojitra Road  
Vallabh Vidyanagar  
388120 Gujarat  
India

Tel: +91 2692 236513

## DENMARK

### **Benzler Transmission A/S**

Dalager 1  
DK-2605 Brøndby,  
Denmark

Tel: +45 36 34 03 00  
Fax: +45 36 77 02 42

## FINLAND

### **Oy Benzler AB** Vanha Talvitie 3C FI-00580 Helsingfors, Finland

Tel: +358 9 340 1716  
Fax: +358 10 296 2072

## SWEDEN & NORWAY

### **AB Benzlers**

Porfyrgatan  
254 68 Helsingborg  
Sweden

Tel: +46 42 18 68 00  
Fax: +46 42 21 88 03

## THAILAND

### **Radicon Transmission (Thailand) Ltd**

700/43 Moo 6  
Amata Nakorn Industrial Estate  
Tumbol Klongtumru  
Muang,  
Chonburi  
20000  
Thailand

Tel: +66 3845 9044  
Fax: +66 3821 3655

## UNITED KINGDOM

### **Radicon Transmission UK Ltd**

Unit J3  
Lowfields Business Park,  
Lowfields Way, Elland  
West Yorkshire, HX5 9DA

Tel: +44 1484 465 800  
Fax: +44 1484 465 801

## USA

### **Radicon Drive Systems, Inc.**

2475 Alft Lane  
Elgin  
Chicago  
Illinois  
60124  
USA

Tel: +1 847 593 9910  
Fax: +1 847 593 9950

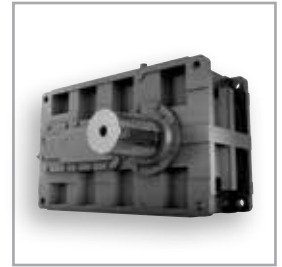
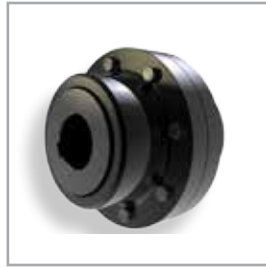
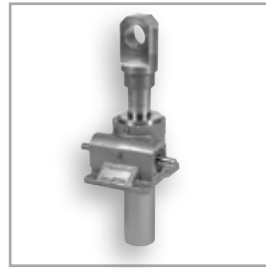

benzlers<sup>⚙️</sup>  
radicon<sup>⚙️</sup>

**Benzlers**

Denmark +45 36 340300  
Finland +358 9 3401716  
Germany +49 800 3504000  
Italy +39 02 824 3511  
Sweden +46 42 186800  
The Netherlands +31 77 3245900  
[www.benzlers.com](http://www.benzlers.com)

**Radicon**

Thailand +66 38459044  
United Kingdom +44 1484 465800  
USA +1 847 5939910  
[www.radicon.com](http://www.radicon.com)